



# APPLICATION GUIDE

## Roof Curbs for NexusPremier™ Rooftop Units

NEW RELEASE • 5553807-JAD-1018

## Table of Contents

General.....	2
Recommendations.....	2
Roof Curb Fundamentals .....	3
Field Provided Roof Curbs .....	3
Factory Provided Roof Curbs .....	3
Alternate Mountings.....	3
Field Provided Steel Dunnage.....	3
Field Provided Concrete Slab.....	3
Curb Preparation .....	3
Typical Curb Styles.....	4
Flat Curbs.....	4
Sloped Curbs.....	4
Vibration Isolated Curbs .....	4
Seismic Curbs .....	4
Roof Curb Application.....	6
Structural Cross Supports .....	6
Roof Curb Drawings .....	6
Frequently Asked Questions .....	7
What are spring isolation curbs?.....	7
When would I need a curb with spring isolation?.....	7
What is structural fatigue?.....	7
What is fatigue analysis?.....	7
Who installs the insulation required to prevent curb condensation?.....	7
What are seismic isolation curbs?.....	7
References .....	8

## General

This document contains guidelines for installing and sealing roof mounted outdoor HVAC equipment on curbs. The guidelines are not standards, warranties or certifications. These guidelines serve only as a supplement and do not supercede the specific installation instructions supplied with the unit curb. This guide does NOT address roof penetrations.

The roof curb is the interface between the building and the rooftop unit. It supports the rooftop unit and transfers the load onto the roof's structural members, streamlines ductwork connections, and provides the means to complete the weatherproof seal with the roof.

The roof curb should be installed by an experienced erector. Improper installation or faulty construction can result in roof leaks and continued maintenance problem for the building owner.

**NOTE:** For more information, please reference:

- Unit dimensions can be found in the *NexusPremier™ 25–50 Ton Rooftop Unit Tech Guide* (Johnson Controls 2018a). A base rail cross sectional drawing is available in the *Installation and Maintenance Manual* (Johnson Controls 2018b).
- The installation instructions shipped with each roof curb.
- *Guidelines for Roof Mounted Outdoor Air-Conditioner Installations* (AHRI and SMACNA 1997).
- *Construction Details*, volume 4 of the *Roofing & Waterproofing Manual* (NRCA 2006, vol. 4) and the *Architectural Sheet Metal Manual* (SMACNA 2012) for flashing details.

## Recommendations

Standard roof curbs can be ordered from Johnson Controls at the time the rooftop unit is ordered. Roof curbs ordered from Johnson Controls are designed to be robust and properly designed to support the NexusPremier rooftop unit. As part of the roof curb package provided by Johnson Controls, the included documentation provides vital data such as unit dimensions, weight, component details, cross braces, supply and return opening layout dimensions, and notes that are unique to each unit. Buying a Johnson Controls roof curb ensures that this data is included with each unit. Roof curbs can be ordered from another manufacturer, but the contractor assumes all liability related to the roof curb and mounting.

The purchased roof curb does not provide roof system materials required in the flashing of a structural member through a roof deck. Thus, the roof curb does not include a counter-flashing receiver. Never attach roof flashing directly to a rooftop unit.



### CAUTION

The manufacturer does not recommend vibration isolation be provided on both the fan skid inside the unit and the roof curb outside the unit without analysis of the specific installation. Using improperly designed internal and external isolation springs can increase vibration and can cause damage to equipment. Dual vibration isolation applications must be designed by a licensed professional engineer specializing in vibration isolation design.

## Roof Curb Fundamentals

### Field Provided Roof Curbs

The curb should be structurally capable of supporting intended loads and designed so that drains, power lines, etc. do not penetrate roof flashing. For curb heights less than 14 inches, make accommodations that allow for the proper depths of the drain pan trap and humidifier trap. The curb should be furnished with a wood nailer, which provides a minimum of 3.5 inches of nailer surface (mounted at the top of the curb) to permit mechanical attachment of the flashing material. Caution should be used when considering the use of wood that has been treated with an oil borne preservative for wood nailers. The oil that is used in many lumber treatments can act as a solvent on roofing materials and can cause bitumen drippage. The curb should provide a minimum clearance of 10 inches between the top of the finished roof surface and the top of the wood nailer, continuous around the curb perimeter. The recommended nominal curb height is at least 14 inches.

Johnson Controls furnishes a wood nailer and gasketing with each curb. Although insulated curbs are often specified, the roofing contractor is ultimately responsible to provide roof insulation. It is rare (less than 1% of instances) for a curb manufacturer to provide a flange-turned-out curb that is insulated at the factory. Curbs manufactured for Johnson Controls rooftop units are flange-turned-out style curbs, therefore they do not include factory insulation as a standard.

### Factory Provided Roof Curbs

Standard factory curb height is 14 inches. Curb dimensions and material vary depending on unit size and options. Refer to the factory roof curb drawing provided with the unit for specific curb information. Curb material is not painted.

## Alternate Mountings

### Field Provided Steel Dunnage

It is acceptable to design alternative stand mounting that consists of custom structural steel wide flange I-beam frames. Alternative stand mounting can be used to accommodate every variety of mounted HVAC equipment.

The rooftop unit must be supported around the entire perimeter to ensure unit integrity. The structural steel perimeter frame shall be designed and provided by

others. When this type of placement is required, be sure to keep unit access in mind. Catwalks or other forms of unit access may be required to one or both sides of the unit depending on your area of the country and the local codes that are enforced. Please check with local officials to ensure the application conforms to local codes and regulations. It is NOT acceptable to use individual piers or columns alone to support the rooftop unit. A full perimeter support IS required for dunnage steel.

Please refer to the *Installation and Maintenance Manual* (Johnson Controls 2018b) for base rail drawing and unit dimensions.

### Field Provided Concrete Slab

It is acceptable to mount units at ground level locations. It is important that the units be installed on a substantial base that will not settle or cause strain on the refrigerant lines and sheet metal that could result in possible leaks. A one-piece concrete slab with footers extended below the frost line is highly recommended. Additionally, isolate the slab from the main building foundation to prevent noise and vibration transmission to the building structure. For ground level installations, take precautions to protect the unit from tampering by or injury to unauthorized persons. Make accommodations that allow for the proper depths of the drain pan trap and humidifier trap. Service clearances must be maintained at all times.

## Curb Preparation

Unit and curb orientation is critical. The airflow insignia is shown on the roof curb and unit detail drawings. As a point for reference, the rooftop unit has a front, rear, left, right, top, and bottom sides. See *Figure 1 on page 4*.

The roof curb **must be square and level** prior to setting equipment. The factory provides cross braces as required of each unit. The cross braces must be installed as shown on the factory roof curb drawing provided with the unit. Braces of the proper quantity, location, and material gauge to support the unit load are furnished with the curb.

Prior to setting the unit onto the curb, the installer must ensure that a sealing material is positioned between the unit and the curb to provide a watertight connection. The rooftop unit may be mounted immediately after the curb is installed. Roofing may be completed after setting the unit.

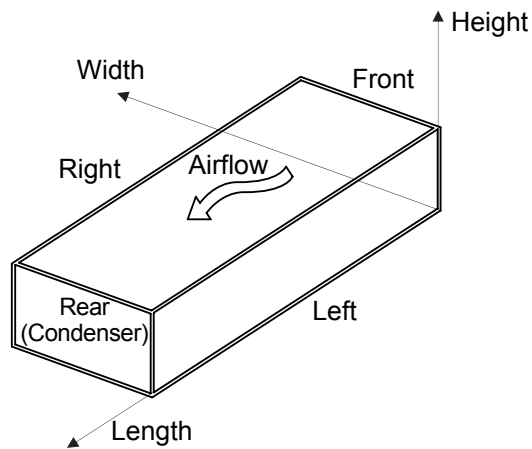

LD08205

Figure 1: Unit and Curb Orientation

## Typical Curb Styles

The following are typical curb styles used with rooftop units.

### Flat Curbs

See Figure 2.

- Curb dimensions and material vary depending on unit size and options. Refer to the factory roof curb drawing provided with the unit for specific curb information. Cross bracing is provided as needed

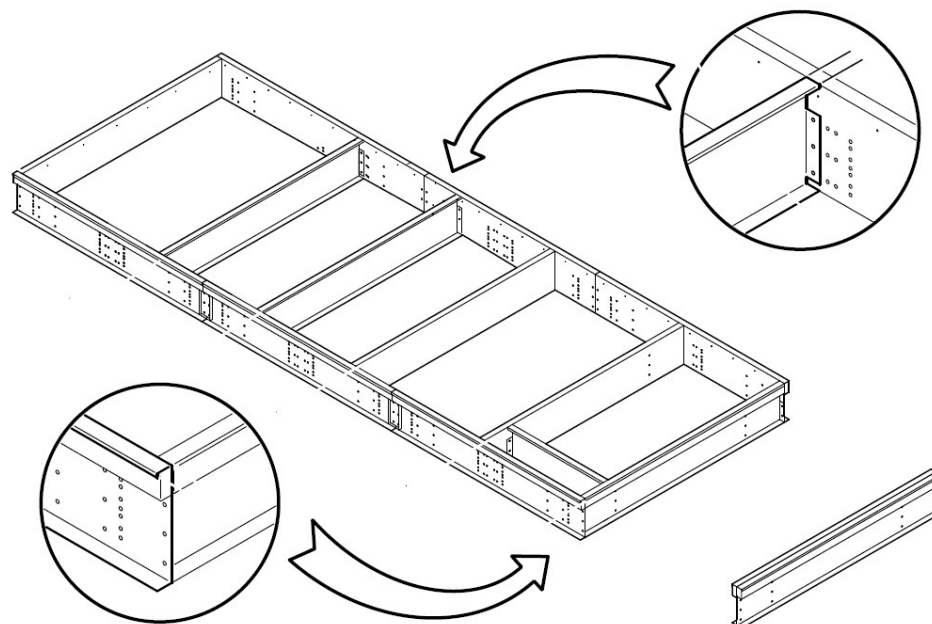

Figure 2: Typical Flat Roof Curb

## Sloped Curbs

See Figure 3 on page 5. Sloped curbs must be field supplied.

- Long side, maximum slope = 0.5 inch per 12 inches
- Short side, maximum slope = 1 inch per 12 inches
- Curb height is the height of the curb at the shorter wall

## Vibration Isolated Curbs

See Figure 8 on page 7. Vibration isolated curbs must be field supplied.

- Flat or sloped
- The curb includes vibration isolation between the equipment and the roof

## Seismic Curbs

See Figure 8. Seismic curbs must be field supplied.

- Flat or sloped.
- Curb must be capable of supporting seismic loads of two options.
  - Up to 0.75 gs
  - Up to 2.06 gs

### NOTES:

1. Curb, curb rest, nailer, and gasket only furnished by the factory. All other parts are furnished by others.
2. Roof curb shipped in pieces for field assembly.
3. Roof curb must be installed square and level.
4. Curb dimensions and material vary depending on unit size and options. Refer to the factory roof curb drawing provided with the unit for specific curb information.
5. Curbs must be fully supported by the roof structure.

LD27647

### Length-Wise Slopes

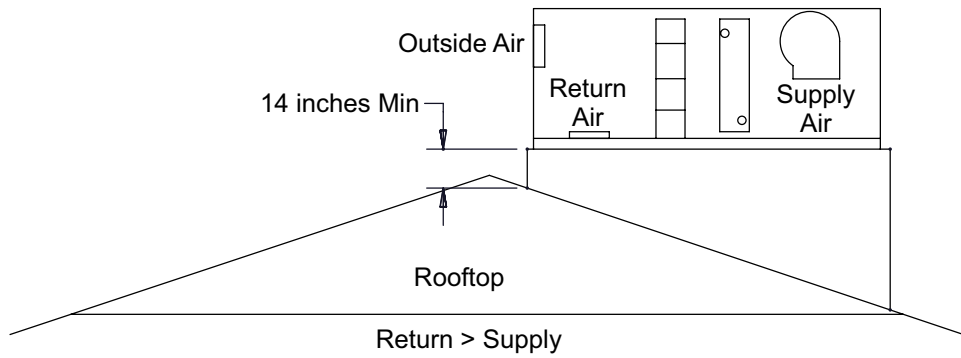
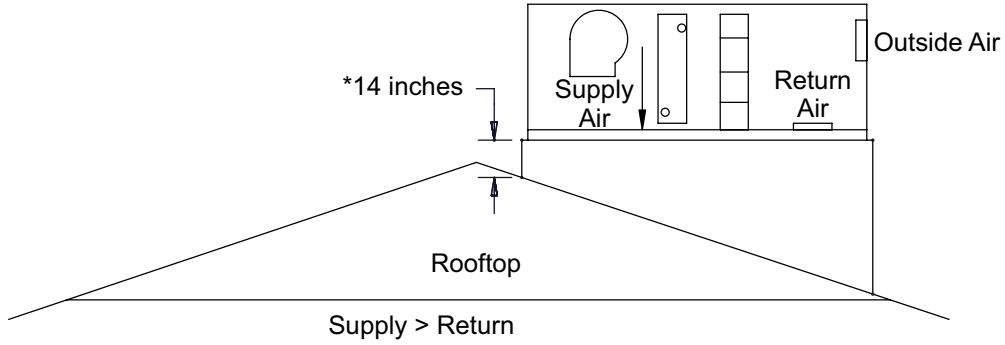

### Width-Wise Slopes

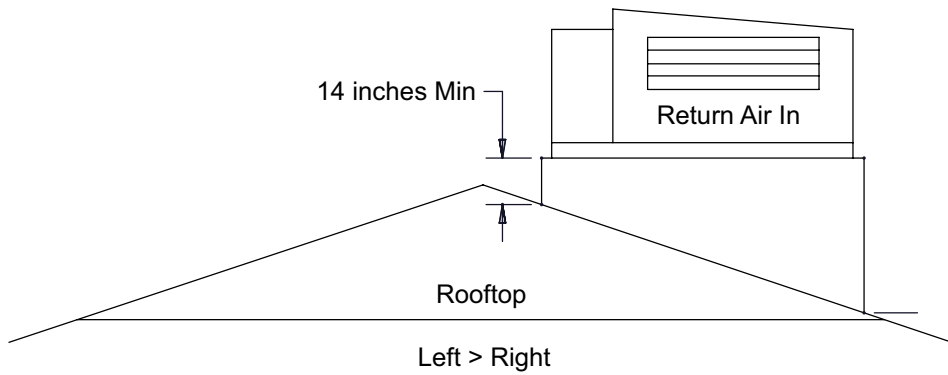
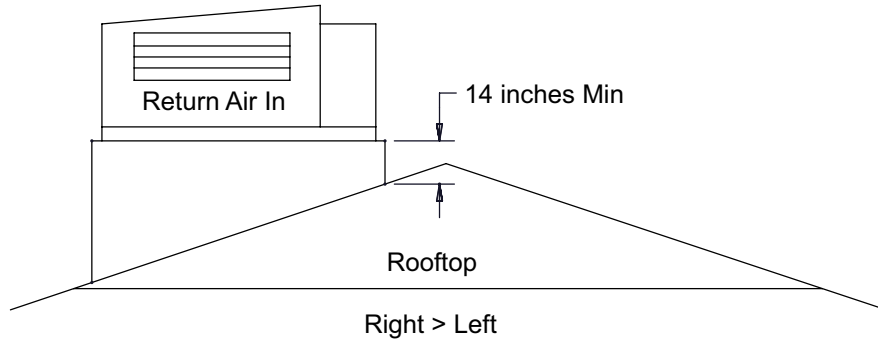

**\*NOTE:** Curb height selected is always the shortest dimension.

**Figure 3: Sloped Curb**

## Roof Curb Application

The top of the roof curb should be level after installation. A separate counter-flashing receiver should be installed prior to the installation of the equipment. All receivers should be of watertight construction. For details concerning counter-flashing receivers, refer to the latest edition of the SMACNA *Architectural Sheet Metal Manual* (SMACNA 2012).

If the installing contractor makes penetrations through the unit floor, care must be taken to seal the penetration properly to prevent air and water leakage into the roof curb.

## Structural Cross Supports

Roof damage may occur when there are no cross supports at the front and rear curb flange. Without full perimeter structural support, roof deflection and related damage will occur.

## Roof Curb Drawings

Compare the roof curb layout drawing to the submittal documents for the rooftop unit to confirm that the details match. Each rooftop unit has a dedicated drawing that corresponds with the features that are included in the unit.

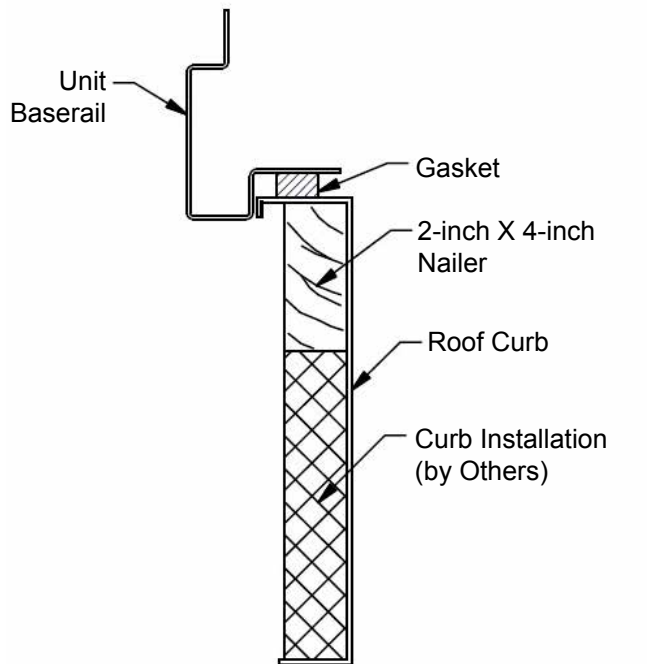
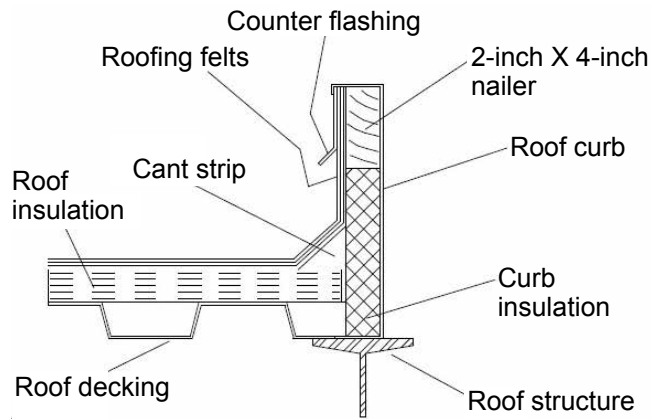

Figure 4: Curb Detail

LD27616



LD27648

Figure 5: Type A Suggested Curb Installation

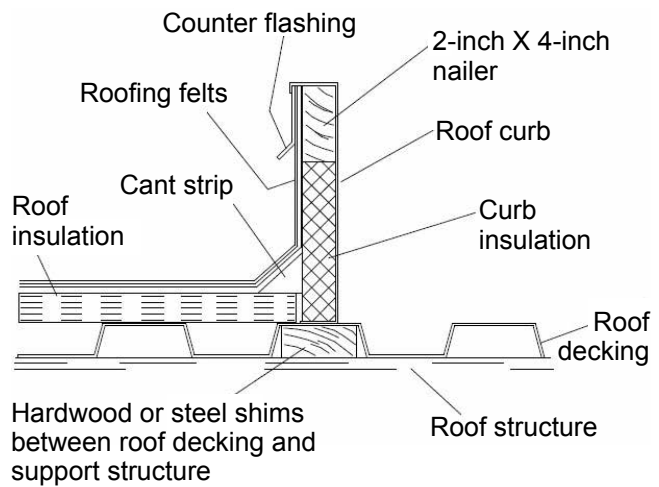

LD27649

Figure 6: Type B Suggested Curb Installation

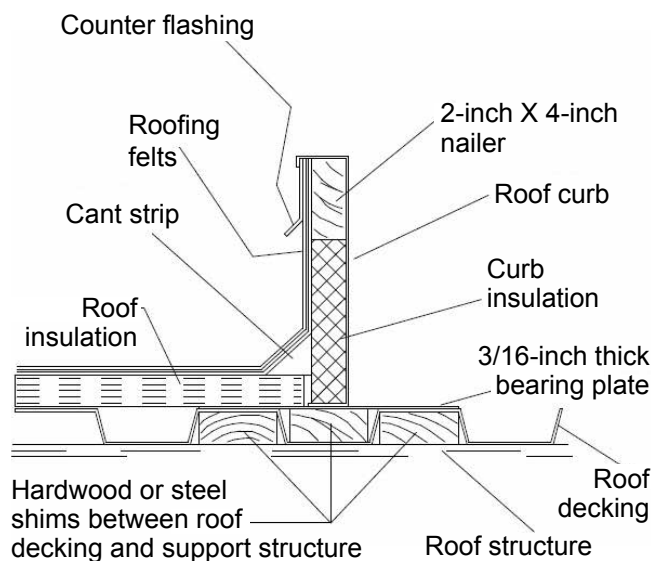

LD27650

Figure 7: Type C Suggested Curb Installation

## Frequently Asked Questions

### What are spring isolation curbs?

They are roof curbs that incorporate adjustable spring isolators into the curb as a single component. Most isolation curbs are designed for 1-inch static deflection springs. The springs are mechanically fastened and sized within the frame to ensure uniform deflection for the entire system. The vibration elimination portion of the curb is constructed of structural steel and should be designed to match the bottom of the rooftop unit.

### CAUTION

The manufacturer does not recommend vibration isolation be provided on both the fan skid inside the unit and the roof curb outside the unit without analysis of the specific installation. Using improperly designed internal and external isolation springs can increase vibration and can cause damage to equipment. Dual vibration isolation applications must be designed by a licensed professional engineer specializing in vibration isolation design.

### When would I need a curb with spring isolation?

Whenever the roof may be subjected to harmful vibrations from roof mounted equipment. Rotating mechanical equipment systems are capable of producing natural frequencies or vibrations that annoy the occupants of a building, disturb sensitive equipment, and can cause structural fatigue. If ignored, harmful frequencies/vibrations can lead to potentially hazardous situations. Spring isolation curbs help to eliminate vibration and structural fatigue problems.

### What is structural fatigue?

Fatigue is damage caused by repeated cycling of a specific load. Load cycling causes progressive localized damage to many materials. Most fatigue cracks initiate and propagate in regions where the strain is most severe. The process of fatigue consists of three stages: initial crack initiation, progressive crack growth across the material, and final sudden fracture of the remaining cross section.

### What is fatigue analysis?

A fatigue analysis is a study of the structural parts of a building and the effects that vibration-producing equipment have on the building, other components, and the equipment itself. Engineering firms that specialize in the fields of vibration, noise, and acoustics should be consulted. An analysis would indicate if a curb with spring isolation and isolation rail is needed.

### Who installs the insulation required to prevent curb condensation?

The roofing contractor usually provides insulation in the roof curb.

### What are seismic isolation curbs?

The seismic isolation curb incorporates a fully adjustable support system specifically designed for unit vibration and seismic/wind restraint. Most seismic zones require a seismic isolation rail as part of the roof curb (ASCE 2003, sec. 9; ICC 2002, sec. 1621).

Seismic isolation curbs are designed to meet superimposed live and dead loads (including equipment and other construction loads) to be supported on the roof curb. The roof curb contains mountings designed and rated to resist seismic forces in all directions. A typical example is shown in *Figure 8*.

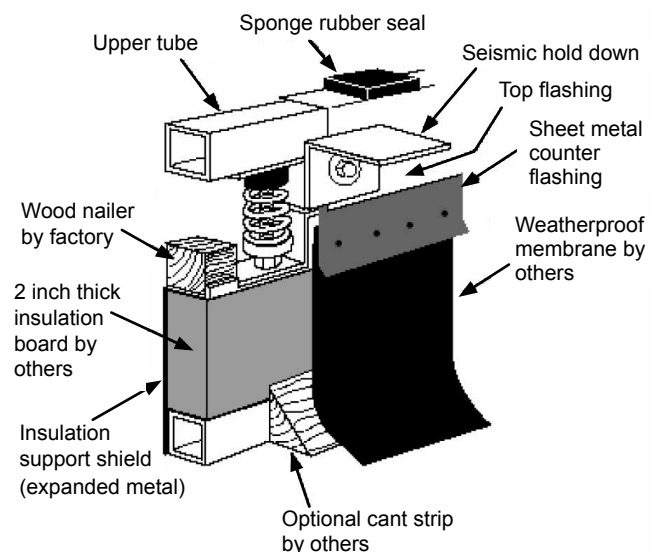

LD26899

**Figure 8: Roof Curb with Seismic/Wind Restraint**

## References

AHRI (Air-Conditioning, Heating, and Refrigeration Institute) and SMACNA (Sheet Metal and Air Conditioning Contractors' National Association). June 1997. *Guidelines for Roof Mounted Outdoor Air-Conditioner Installations*. Arlington and Chantilly, VA: AHRI and SMACNA.

ASCE (American Society of Civil Engineers). 2003. *Minimum Design Loads for Buildings and Other Structures*. SEI/ASCE 7-02. Reston, VA: ASCE.

ICC (International Code Council). 2002. *2003 International Building Code*. Country Club Hills, IL: ICC, Inc.

Johnson Controls. 2018a. *NexusPremier™ 25–50 Ton Rooftop Unit Tech Guide*. 5513350-JTG-1018. York, PA: Johnson Controls.

———. 2018b. *NexusPremier™ 25–50 Ton Rooftop Unit Installation and Maintenance Manual*. 5586959-JIM-1218. York, PA: Johnson Controls.

NRCA (National Roofing Contractors Association). 2006. *The NRCA Roofing and Waterproofing Manual*. Vol. 4, *Construction Details*. Rosemont, IL: NRCA.

SMACNA. 2012. *Architectural Sheet Metal Manual*. Chantilly, VA: SMACNA.

