

HORIZONTAL SURGE DRUM Single Flow

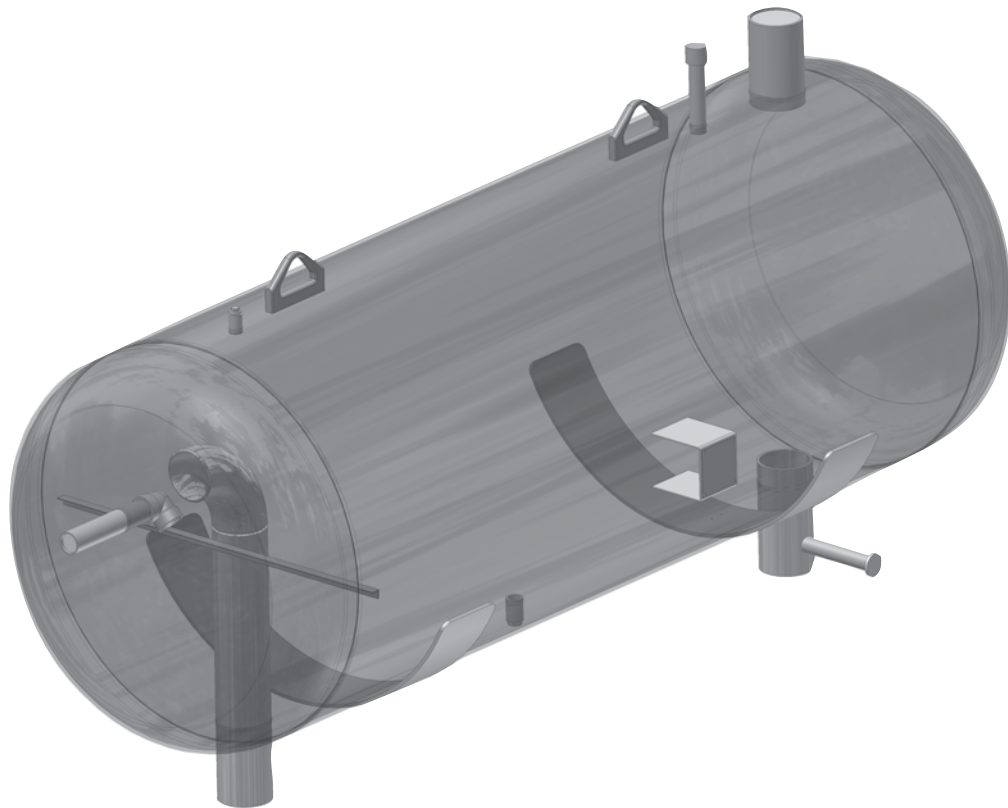

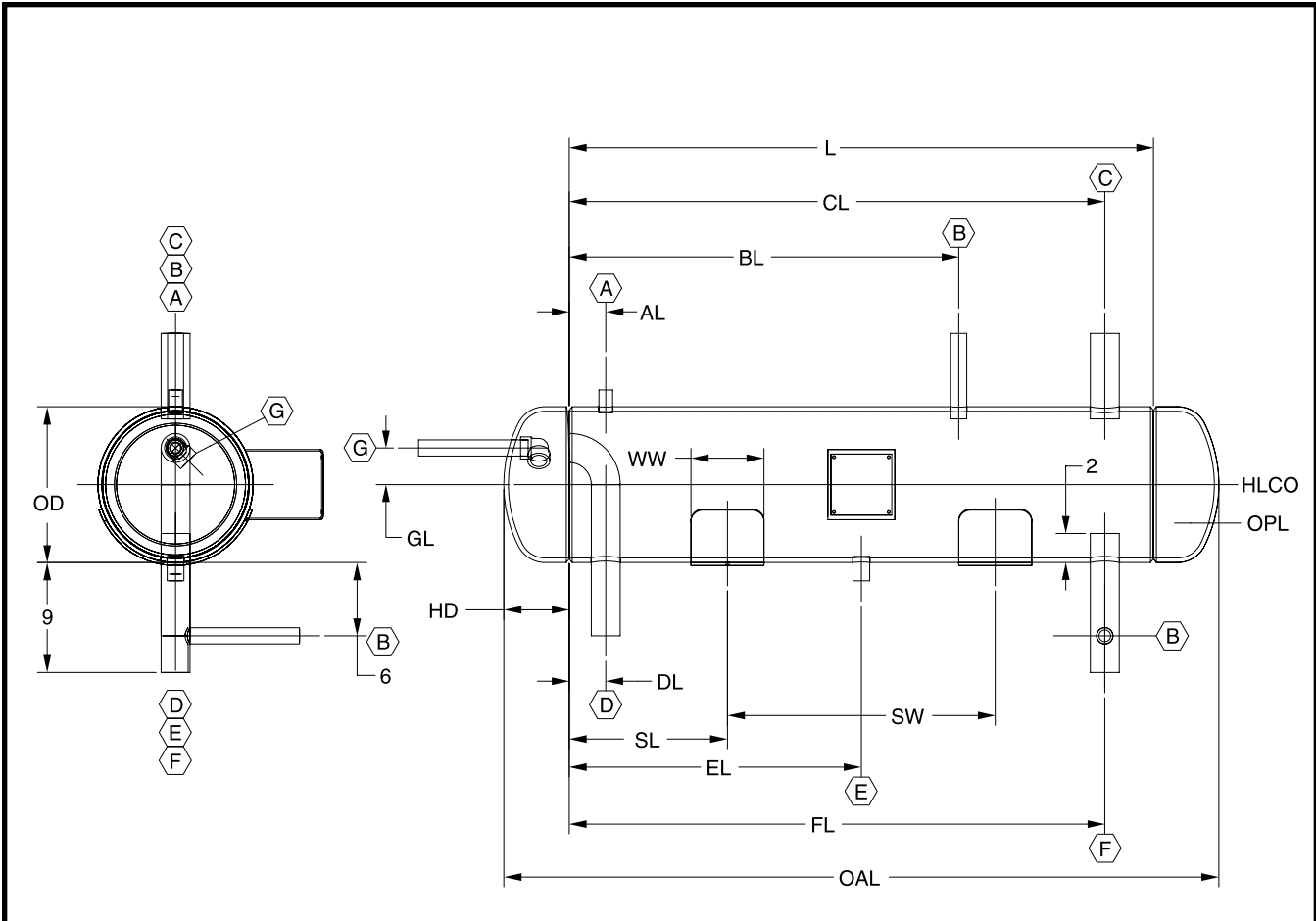

NOTES:

1. All dimensions and nozzle nominal pipe sizes are given in inches unless noted otherwise.
2. Operating charge at OPL is based on ammonia @ +0°F RT.
3. Nozzle connections are supplied as pipe stubs unless otherwise specified as a coupling (Cplg).
4. Couplings are ASME B16.11 Class 3000 "full" couplings.
5. Nozzles are sized for R-717 and should not be used with other refrigerants (e.g. R-507).
6. Nameplate bracket is approximately 6 inches deep to allow for insulation.
7. All dimensions are subject to change; please consult factory for certified drawings.
8. Vessels are built in accordance with ASME Boiler & Pressure Vessel Code, Section VIII, Division 1.

Key to Nozzle/Coupling Locations:

- | | | |
|-----------------------|---------------------------|--------------------------|
| A - Relief (Coupling) | S - Wear Plate Separation | OPL - Operating Level |
| B - Level Column | SL - Left Wear Plate | HLCO - High Level Cutout |
| C - Gas Outlet | WW - Wear Plate Width | |
| D - Wet Return | OD - Outside Diameter | |
| E - Drain (Coupling) | HD - Head Depth | |
| F - Liquid Outlet | L - Shell Length | |
| G - Liquid Makeup | OAL - Overall Length | |

Figure 1. Data and Dimensions

HORIZONTAL SURGE DRUM CAPACITIES R-717 ⁽¹⁾

Model Number	Operating Temperature										
	Two Stage				Single Stage						
	-50°F	-40°F	-30°F	-20°F	-20°F	-10°F	0°F	10°F	20°F	30°F	40°F
HSDS-12-60	8.4	9.7	11.1	12.7	11.0	12.5	14.0	15.7	17.4	19.3	21.2
HSDS-16-72	13.5	15.6	17.9	20.4	17.8	20.1	22.6	25.3	28.1	31.1	34.3
HSDS-20-86	21.5	24.9	28.6	32.6	28.3	32.1	36.1	40.3	44.8	49.6	54.6
HSDS-24-88	31.4	36.4	41.7	47.5	41.3	46.8	52.6	58.8	65.4	72.4	79.6
HSDS-30-113	49.7	57.5	66.0	75.2	65.4	74.0	83.2	93.1	103.0	115.0	126.0
HSDS-36-116	72.2	83.6	95.9	109.0	95.0	108.0	121.0	135.0	150.0	166.0	183.0
HSDS-42-119	98.9	114.0	131.0	150.0	130.0	147.0	166.0	185.0	206.0	228.0	251.0
HSDS-48-122	128.0	149.0	170.0	194.0	169.0	191.0	215.0	240.0	267.0	296.0	326.0
HSDS-54-125	184.0	212.0	244.0	277.0	241.0	273.0	307.0	343.0	382.0	423.0	465.0
HSDS-60-128	228.0	263.0	302.0	344.0	299.0	339.0	381.0	426.0	473.0	524.0	576.0

1. Capacities are given in tons of refrigeration, (R-717)
2. Two-stage capacities based on +35°F liquid feed temperature.
3. Single-stage capacities based on +95°F liquid feed temperature.

DIMENSIONAL DATA

Model Number	MAWP	OD	OAL	HD	L	Uninsulated Dry Wt. (lbm)	R-717 Operating Charge (lbm)	Weight (lbm) w/Max Charge	Surge Vol. (cu-ft)	OPL	HLCO
HSDS-12-60	300	12 ³ / ₄	60	6	48	290	38.2	370	0.91	4	6 ³ / ₈
HSDS-16-72	300	16	72 ³ / ₈	6 ³ / ₁₆	60	300	57.4	460	2.39	4	8
HSDS-20-86	300	20	86 ³ / ₈	7 ³ / ₁₆	72	660	73.3	950	5.17	4	10
HSDS-24-88	300	24	88 ³ / ₈	8 ³ / ₁₆	72	810	82.0	1,240	8.31	4	12
HSDS-30-113	250	30	113 ³ / ₈	9 ¹¹ / ₁₆	94	1,310	118.9	2,180	18.07	4	15
HSDS-36-116	250	36	116 ³ / ₈	11 ³ / ₁₆	94	1,610	132.3	2,900	27.79	4	18
HSDS-42-119	250	42	119 ³ / ₈	12 ¹¹ / ₁₆	94	1,920	144.5	3,710	39.72	4	21
HSDS-48-122	250	48	122 ¹ / ₂	14 ¹ / ₄	94	3,000	147.5	5,370	53.50	4	24
HSDS-54-125	250	54	125 ¹ / ₂	15 ³ / ₄	94	3,450	157.8	6,510	70.02	4	27
HSDS-60-128	250	60	128 ¹ / ₂	17 ¹ / ₄	94	3,930	167.5	7,790	89.03	4	30

Model Number	Nozzle / Coupling NPS ^{(3) (4) (5)}							AL	BL	CL	DL	EL	FL	GL	S	SL	WW
	A	B	C	D	E	F	G										
HSDS-12-60	1/2	1	2	2	1	2	3/4	3	32	44	3	24	44	3	22	13	6
HSDS-16-72	1/2	1	2 ¹ / ₂	2 ¹ / ₂	1	2 ¹ / ₂	1	4	44	56	4	30	56	3	32	14	6
HSDS-20-86	1/2	1	3	3	1	3	1 ¹ / ₄	4	56	68	4	36	68	3	44	14	6
HSDS-24-88	1/2	1	3	3	1	4	1 ¹ / ₄	4	55	67	4	36	67	3	42	15	6
HSDS-30-113	3/4	1 ¹ / ₄	4	4	1	4	1 ¹ / ₂	5	77	89	5	47	89	4	62	16	6
HSDS-36-116	3/4	1 ¹ / ₄	4	4	1	5	2	5	76	88	5	47	88	4	58	18	8
HSDS-42-119	3/4	1 ¹ / ₄	5	5	1	5	2	6	76	88	6	47	88	6	58	18	8
HSDS-48-122	3/4	1 ¹ / ₄	5	5	1	6	2	6	76	88	6	47	88	6	56	19	8
HSDS-54-125	3/4	1 ¹ / ₂	6	6	1	6	2 ¹ / ₂	6	76	88	6	47	88	6	54	20	8
HSDS-60-128	3/4	1 ¹ / ₂	6	6	1	8	3	6	74	86	6	47	86	6	50	22	8

Q-NET™ network technology...

Connect Your PC
with QUANTUM™LX!

*Take full advantage of Q-NET™
technology with all Frick products!*

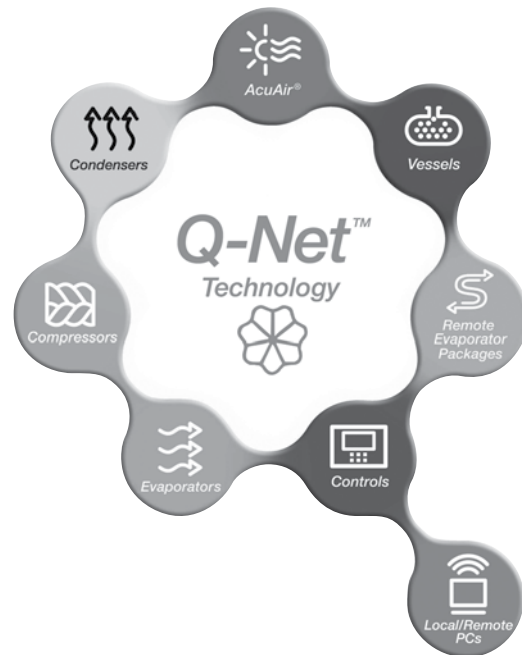

System integration is what we do...

- Q-NET™... supports open-protocols for SCADA systems (i.e. Allen-Bradley® DF1, Modbus RTU, Modbus ASCII, and Industrial Ethernet Protocols)
- Q-NET™... connects instantly for local or remote access; no software required
- Q-NET™... can be applied to both new and existing systems
- Q-NET™ means precise control 24 hours a day, seven days a week
- Q-NET™ distributed architecture mean faster, easier, economical installations
- Q-NET™ delivers increased operating efficiency and lowers energy costs

Available on Frick screw compressors, condensers, evaporators, AcuAir® hygienic air handlers, and refrigerant vessels.