



BY JOHNSON CONTROLS

Form 120-200 IOM (MAR 2010)

INSTALLATION - OPERATION - MAINTENANCE

File: EQUIPMENT MANUAL - Section 120
Replaces: S120-200 IOM (JUN 2008)
Dist: 3, 3a, 3b, 3c

VERTICAL and HORIZONTAL RECIRCULATOR PACKAGES

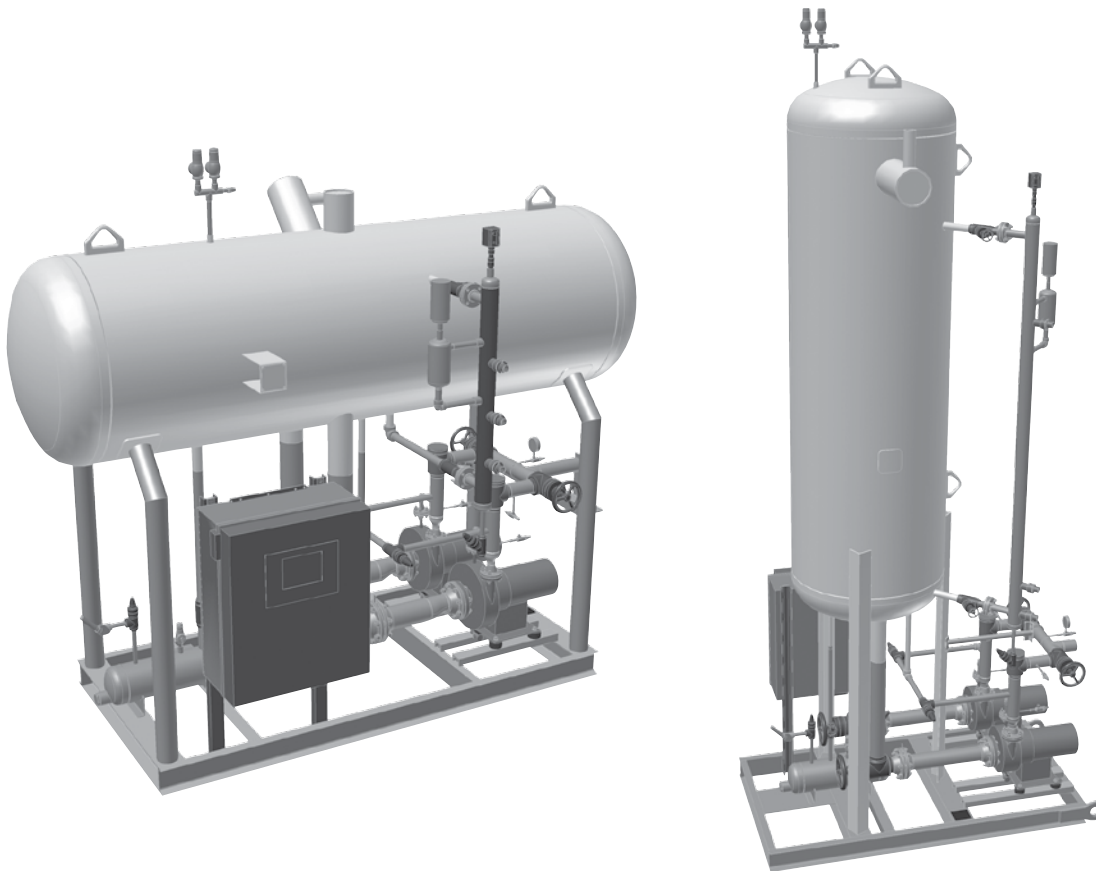

THIS MANUAL CONTAINS RIGGING, ASSEMBLY, START-UP, AND MAINTENANCE INSTRUCTIONS. READ THOROUGHLY BEFORE BEGINNING INSTALLATION. FAILURE TO FOLLOW THESE INSTRUCTIONS COULD RESULT IN DAMAGE OR IMPROPER OPERATION OF THE UNIT.

Please check www.johnsoncontrols.com for the latest version of this publication.

Contents

PREFACE.....	3	Special Features.....	15
DESIGN LIMITATIONS.....	3	Technical Data.....	15
JOB INSPECTION.....	3	Function and Factory Setting.....	16
TRANSIT DAMAGE CLAIMS.....	3	Setting of Refrigerant.....	17
UNIT IDENTIFICATION.....	3	Signal Damping.....	17
RIGGING and HANDLING.....	3	Procedure:.....	17
INSTALLATION		Calibration of the AKS 41 / 41U.....	17
HOLDING CHARGE AND STORAGE.....	4	Adjusting the min. /max. calibration points:.....	17
ELECTRICAL.....	4	Reset To Factory Setting.....	18
OPERATION		Green LED Indication.....	18
STARTING THE STANDBY PUMP.....	5	Instructions.....	18
PUMP SUCTION STRAINER (OPTIONAL).....	5	Necessary connections.....	18
OPERATION OF CORNELL PUMPS.....	6	Application dependent connections.....	19
Before Starting The Pump.....	6	EKC 347 – ON/OFF Application.....	19
Starting the Pump.....	6	Menu Survey.....	20
Recommendations.....	6	Operation.....	20
OPERATION OF TEIKOKU PUMPS.....	6	Display.....	20
INITIAL START-UP.....	6	Light-emitting diodes (LED) on front panel.....	20
RUNNING.....	6	The buttons.....	20
ICM MOTOR VALVES.....	7	Examples of operations.....	20
ICAD 600 / ICAD 900.....	7	Error Messages.....	21
Fail Safe supply options.....	7	MAINTENANCE	
The ICM Concept.....	7	OIL REMOVAL.....	22
Features (valve).....	8	SAFETY RECOMMENDATIONS.....	23
Design (valve).....	8	TROUBLESHOOTING.....	23
Connections.....	8	P and I DIAGRAMS.....	24
Technical data (valve).....	8	ELECTRICAL PANEL LAYOUT.....	29
Function (valve).....	9	WIRING DIAGRAMS.....	31
ICAD ACTUATOR.....	9	PROPER INSTALLATION OF ELECTRONIC EQUIPMENT IN AN INDUSTRIAL ENVIRONMENT.....	35
Approvals.....	11	WIRE SIZING.....	35
Function (actuator).....	11	VOLTAGE SOURCE.....	35
OPERATION OF DANFOSS		GROUNDING.....	36
LIQUID INJECTION VALVE.....	11	VFD Applications.....	36
Parameter list.....	13	CONDUIT.....	37
Service.....	13	WIRING PRACTICES.....	37
Introduction.....	14	COMMUNICATIONS.....	39
Features.....	14	UPS Power and Quantum™LX Panels.....	39
Design.....	14		

SAFETY PRECAUTION DEFINITIONS



Indicates an imminently hazardous situation which, if not avoided, will result in death or serious injury.



Indicates a potentially hazardous situation or practice which, if not avoided, will result in death or serious injury.



Indicates a potentially hazardous situation or practice which, if not avoided, will result in damage to equipment and/or minor injury.

NOTE:

Indicates an operating procedure, practice, etc., or portion thereof which is essential to highlight.

PREFACE

This manual has been prepared to acquaint the owner and serviceman with the INSTALLATION, OPERATION, and MAINTENANCE procedures as recommended by Johnson Controls-Frick for Vertical and Horizontal Liquid Recirculator Packages.

It is very important that these units be properly applied to an adequately controlled refrigeration system. Your authorized Johnson Controls-Frick representative should be consulted for his expert guidance in this determination.

Proper performance and continued satisfaction with these units is dependent upon:

- CORRECT INSTALLATION**
- PROPER OPERATION**
- REGULAR, SYSTEMATIC MAINTENANCE**

To ensure correct installation and application, the equipment must be properly selected and connected to a properly designed and installed system. The Engineering plans, piping layouts, etc. must be detailed in accordance with the best practices and local codes, such as those outlined in ANSI/ASHRAE Standard 15 and ASME B-31.5 Piping Guidelines.

DESIGN LIMITATIONS

Frick standard recirculator vessels are stamped at 250# DWP at -20°F to +250°F. For applications below -20°F, vessels will be dual rated if required.

For applications below -55°F, vessel and piping materials change. Please reference Pressure Vessel manual E120-100 SED or consult Vessel Engineering in Waynesboro, PA.

JOB INSPECTION

Immediately upon delivery examine all crates, boxes and exposed component surfaces for damage. Unpack all items and check against shipping lists for any discrepancy. Examine all items for damage in transit.

TRANSIT DAMAGE CLAIMS

All claims must be made by consignee. This is an ICC requirement. Request immediate inspection by the agent of the carrier and be sure the proper claim forms are executed.

Report damage or shortage claims immediately to Johnson Controls-Frick Sales Administration Department, in Waynesboro, PA.

UNIT IDENTIFICATION

Each unit has an identification data plate mounted on the front of the control panel. If there is no control panel provided, the data plate will be mounted to the unit. Please see sample name plate in Figure 1.

NOTE: When ordering repair parts for the recirculator unit, please provide the model and Johnson Controls-Frick sales order number.

RIGGING and HANDLING

Use a crane and rigging whenever the unit is moved. **DO NOT USE A FORK LIFT.** Reference the general arrangement drawing for package weights.



CAUTION Spreader bars should be used on both the length and width of the package to prevent damage to the package. Appropriate adjustment in the lifting points should be made to compensate for the center of gravity.



WARNING Unit may be top heavy. Lifting operators must use extreme care to check the level and stability of the load before lifting the load more than a few inches. Impose an imbalance by sequentially adding weight to each corner and carefully observing the load reaction to make sure the load does not shift. Balancing chains, cables or straps are essential in both directions to prevent load shift and instability during rigging. Call Johnson Controls-Frick Engineering for an estimate of the location of the center of gravity of the package if one is not given. The center of gravity may NOT be located in the center of the package.

NOTES:

1. Reference OSHA Safety And Health Standards (29 CFR 1910), sections 1910.179 and 1910.184.
2. Hooks, chains, cables and spreader bars shall meet manufacturer's recommendations and shall not be overloaded.
3. This unit must be lifted using the lifting lugs provided. Shackles and screw pins shall be provided by others.
4. Spreader bars and balancing chains must be used to prevent instability and damaging or straining system piping, instrumentation or shells.
5. Adjust cables or chains to ensure that the package (skid) is stable and lifted level.
6. Lifting must be done by a qualified operator.

<p>LIQUID RECIRCULATOR PACKAGE</p>
SALES ORDER NUMBER: _____
MODEL: _____
VESSEL SIZE: _____
REFRIGERANT: _____
OPERATING TEMPERATURE: _____
PUMP VOLTAGE: _____
CONTROL VOLTAGE: _____
YEAR MANUFACTURED: _____
100 CV AVENUE, WAYNESBORO, PA. 17268
PHONE: 717-762-2121

Figure 1 - Name Plate

INSTALLATION

The intermediate base between legs is not designed to carry the weight of the unit on rollers or other single-point support. Handle the unit by overhead suspension.

Level the unit lengthwise on the top of the recirculator and crosswise by keeping the level control column in a vertical plane. Use small pieces of flat iron to a thickness of about one inch under each foot, adjusted for proper level and equal load. **NOTE: Use ONLY nonshrinking grout under all base beams so that they are supported continuously from the foundation slab (Reference Johnson Controls-Frick publication S70-210 IB).**

Make all pipe connections in accordance with applicable codes. Refer to General Arrangement drawing for all connection points. External piping loads impose forces and moments in three geometric planes. Since circumstances vary from installation to installation, there is no one set of loading values which Johnson Controls-Frick can provide for all cases. Piping should be designed and supported so that regardless of temperature conditions, there is no pipe strain applied to the package.

To leak test field connections, isolate the pumps and pressurize the unit in accordance with ASME/ANSI piping codes and any applicable local codes. **NOTE: Safety valves are set at 250 psig and should be removed prior to pressure testing.** After final testing of piping, relieve test pressure and replace the safety valves.

HOLDING CHARGE AND STORAGE

Each recirculator package is pressure and leak tested at the factory and then thoroughly evacuated and charged with dry nitrogen to ensure the integrity of the unit during shipping and short term storage prior to installation. Horizontal packages that are shipped in two pieces are pressure and leak tested at the factory before being disassembled for shipment. These units are not charged with dry nitrogen.

NOTE: Care must be taken when opening the unit connections to ensure that the nitrogen charge is safely released.

WARNING Holding-charge shipping gauges are rated for 30 PSIG and are for checking the shipping charge only. They must be removed before pressure testing the system and before charging the system with refrigerant. Failure to remove these gauges may result in catastrophic failure of the gauge and uncontrolled release of refrigerant resulting in serious injury or death.

All units must be kept in a clean, dry location to prevent corrosion damage. Reasonable consideration must be given for proper care of the electrical components.

Units which will be stored for more than two months must have the nitrogen charge checked periodically. Reference the pump manual for long-term storage.

ELECTRICAL

NOTE: Before proceeding with electrical installation, read the instructions in the section "Proper Installation of Electronic Equipment in an Industrial Environment" located in the last section of this manual after Wiring Diagrams.

Recirculator packages may be furnished with or without an electrical control panel. If Johnson Controls-Frick supplies the control panel and wiring, the electrical drawing will be included in the start-up package. If Johnson Controls-Frick does not provide the control panel, the wiring should be done in accordance with the wiring diagrams provided in the back section of this manual.

Care must be taken that the controls are not exposed to physical damage during handling, storage, and installation. The single-box control door must be kept tightly closed to prevent moisture and foreign matter from entry.

NOTE: All customer connections are made in the single-box control mounted on the recirculator package. This is the ONLY electrical enclosure and it should be kept tightly closed whenever work is not being done in it.

CAUTION DO NOT JOG OR START THE AMMONIA PUMPS UNTIL THE SYSTEM IS CHARGED WITH AMMONIA AND THE PUMPS HAVE BEEN SOAKED FOR AT LEAST ONE HOUR (SEE RECIRCULATOR START-UP AND OPERATION).

RECIRCULATOR START-UP AND OPERATION

Check pump manufacturers instructions (enclosed in start-up package), for pump lubrication and start-up procedures before start-up.

Before start-up, each of the hand expansion valves in the system should be opened 1/8 turn. Set the room temperatures low so the solenoids are open and ensure that the isolation valves around the solenoid/expansion valve assembly are open. Check the refrigerant level in the recirculator after the suction, discharge, and vent valves on one of the pumps are open (one pump is standby). Allow the pump to soak for at least an hour. Jog the pump and check the rotation. If the rotation is correct, the gauge on the pump discharge should read 25 PSIG to 35 PSIG above the pump suction pressure. **NOTE: Some pump selections are at higher discharge pressure differentials.**

After starting the pump, each hand expansion valve on each evaporator should be adjusted to obtain the air exit temperature desired. Further adjustment of the pump bypass may be required during the hand expansion valve adjustment process.

STARTING THE STANDBY PUMP

Review the pump manufacturers instructions (enclosed in start-up package) before starting pump. Open the suction, discharge, and vent valves on the standby pump. Allow it to soak at least an hour or as long as possible if it is an emergency change over. This allows the pump to cool down, the bubbles that are formed to return to the recirculator, and helps eliminate cavitation. In an emergency mode, after turning off the operating pump, jog the standby pump a few times to help prime it before starting.

PUMP SUCTION STRAINER (OPTIONAL)

After the system has been in operation for approximately 2 to 4 hours, or after the system has been determined to be clean, the pump suction strainer may be removed.



WARNING Always wear a face shield and chemical goggles and have a gas mask readily available when removing refrigerant from the package. Accidental exposure could result in serious injury or death.

1. Follow the above instructions for starting the standby pump.
2. Isolate the pump that is not in operation.



WARNING Uncontrolled release of refrigerant can cause serious injury or death. When CLOSING isolation valves, consideration shall be given to pressure rise resulting from hydrostatic expansion due to temperature rise of liquid refrigerant trapped between CLOSED valves. Trained technicians are required to purge refrigerant.

3. Purge all refrigerant in the isolated pump through the drain/vent valve supplied. **NOTE: All refrigerant should be drained into a proper container and disposed in accordance with Federal, State, and Local regulations.**
4. Remove the suction strainer in the pump suction spool piece.
5. Install the spacer disc with new gaskets.
6. Ensure that all bolts are torqued properly.
7. Follow "Starting the Standby Pump", if needed, for pump operation.

OPERATION OF CORNELL PUMPS

BEFORE STARTING THE PUMP

Adjust valves in following order (refer to the P and I diagrams for Vertical and Horizontal Recirculator Packages with Cornell Pumps):

1. Close drain valve.
2. Open vent valve.
3. Open valve in discharge line one quarter.
4. Slowly open valve in suction line fully.
5. Open suction vent valve (if present) fully.
6. Fill pump with liquid.
7. Open valve in bypass line.
8. Check wiring of motor and heater. Make certain that once liquid is admitted to pump, heater is on.
9. Allow pump to cool down for approximately one hour.

On any subsequent start-up of the pump, after it has been shut down for one or more days, the oil reservoir should be vented of any vapor accumulation, and oil should be added as necessary. Refer to the Cornell Pump Installation, Operation, and Maintenance manual for instructions on filling and bleeding the reservoir.

STARTING THE PUMP

1. Jog starting switch and observe direction of motor shaft rotation. Direction of proper rotation is indicated by arrow on volute, and is clockwise when viewed from motor location. Correct, if necessary, by changing two connection leads (if three-phase motor).
2. Close discharge valve. **NOTE: If there is no bypass line, leave discharge valve 1/4 open.**
3. Start pump. Close vent valve completely. **NOTE: The vent valve will not vent gasses while the pump is running.**
4. Slowly open pump discharge stop valve while observing discharge pressure and pump behavior. If discharge pressure becomes unstable or cavitation is heard, close discharge stop valve down to the point where pressure stabilizes.
5. Wait approximately five minutes, then start slowly opening discharge stop valve again. As system becomes full, further opening of discharge stop valve should not result in unstable pump performance. If, upon fully opening discharge stop valve, the pump differential pressure* drops more than two to three PSI below the design differential, it will be necessary to turn down hand expansion valves or other control devices to bring the pump back up to design differential.

* Pump discharge pressure minus pump suction pressure.

RECOMMENDATIONS

On initial start-ups or after complete defrost, always start the pump before the compressor unless the system has a method of flow control to limit start-up capacity within the limits of NPSH requirements. In installations where a standby pump is used, it is best to rotate the standby/duty pump assignment at least every three months.

If the pump is isolated from the system by closing valves in the suction and discharge lines, the vent valve is to be opened. Otherwise, ambient heat may cause excessive pressure in the pump leading to casing failure and possible serious personal injury.

OPERATION OF TEIKOKU PUMPS

INITIAL START-UP

The first time the unit is started after initial installation or overhaul, make the following checks before putting the unit back into operation.



Do not run the unit dry, even momentary operation without pumped liquid inside the motor will cause damage. Never operate the pump with its suction and/or motor recirculation line valves closed or throttled (applies to minimum-flow bypass line valve).

Ensure that the following valves are closed (refer to the P and I diagrams for Vertical and Horizontal Recirculator Packages with Buffalo Pumps): suction, discharge, and motor recirculation line valves (minimum flow bypass line valve).

1. Fully open the motor recirculation line valve. Then fully open the suction valve. Note that on refrigerant applications you may see a "frosting over" of the pump and motor.
2. Upon establishing that the motor and pump are fully flooded, run the unit to make sure it operates smoothly. There should be no unusual vibration, grinding, or scraping noises. It is allowable to operate the pump against the closed discharge valve for 1-2 minutes.
3. Check direction of rotation, as follows:
 - a. Making sure the discharge valve is still closed, observe and record discharge pressure with the pump running.
 - b. Stop motor, but do not close or adjust valves.
 - c. Reverse any two line leads at controller to reverse direction of rotation.
 - d. Start the motor and observe and record discharge pressure. The higher of the two discharge pressure readings indicates the correct direction of rotation.
4. Slowly open the discharge valve (minimum flow bypass line valve) until fully open.
5. Check input current to motor under rated load conditions and make sure that the current does not exceed the rating on the motor nameplate.

RUNNING

1. The motor recirculation line valve(s) must be completely open at all times when the pump is operating. Liquid flowing through this line cools and lubricates bearings, carries away heat generated by the motor, and balances axial forces.
2. The unit should run smoothly and quietly under all conditions of load. If unit makes any unusual noises, shut down immediately to prevent possible damage.

NOTE: Please see Teikoku service manual #HE-10677D for complete installation, operation, and service instructions.

ICM MOTOR VALVES



Figure 2 - ICM Motor Valves

ICM motor valves belong to the ICV (Industrial Control Valve) family and are one of two product groups.

ICV types

- ICS - Industrial Control Servo
- ICM - Industrial Control Motor

The motor valve comprises three main components: valve body, combined top cover / function module and actuator.

ICM are direct operated motorized valves driven by actuator type ICAD (Industrial Control Actuator with Display).

ICM valves are designed to regulate an expansion process in liquid lines with or without phase change or control pressure or temperature in dry and wet suction lines and hot gas lines. ICM valves are designed so that the opening and closing forces are balanced, therefore, only two sizes of ICAD actuators are needed for the complete range of ICM from DN 20 to DN 65. The ICM motorized valve and ICAD actuator assembly offers a very compact unit with small dimensions.

The ICM motorized valve and ICAD actuator combinations are as follows:

Actuator	ICAD 600	ICAD 900
Valve size	ICM 20	ICM 40
	ICM 25	ICM 50
	ICM 32	ICM 65

ICAD 600 / ICAD 900

ICAD actuators can be controlled using the following signals:

- 0-20 mA
- 4-20 mA (default)
- 0-10 V
- 2-10 V

ICAD actuators can also operate an ICM valve as an On/Off function supported by a digital input.

The ICM valve can be operated manually via the ICAD actuator or the Multifunction tool for ICM (see the ordering section).

Fail Safe supply options

In the event of a power failure, multiple fail safe options are possible, provided that a ICAD-UPS or similar is used.

During power failure, ICM can be selected to:

- Close ICM
 - Open ICM
 - Stay in the same position, as when power failure occurs
 - Go to a specific ICM valve opening degree
- See the section ICAD UPS for further information.

NOTE: a fail safe supply (battery or UPS) is required.

The ICM Concept

The ICM concept is developed around a modular principle. This gives the possibility of combining function modules and top covers with special valve body size (six) that is available in a variety of connection possibilities.

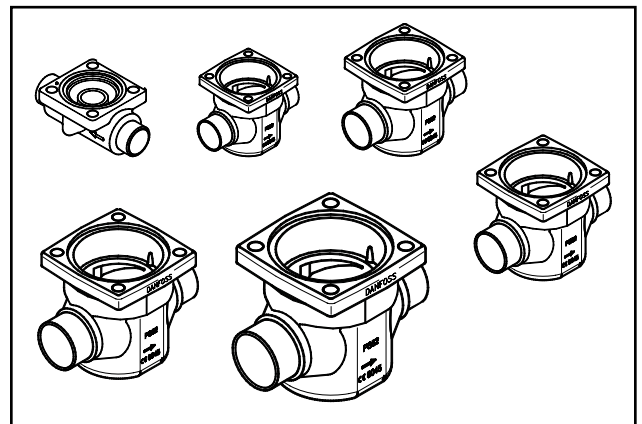

Figure 3 - Six Different Valve Bodies

Each valve body is available with a range of undersized through oversized connection sizes and types.

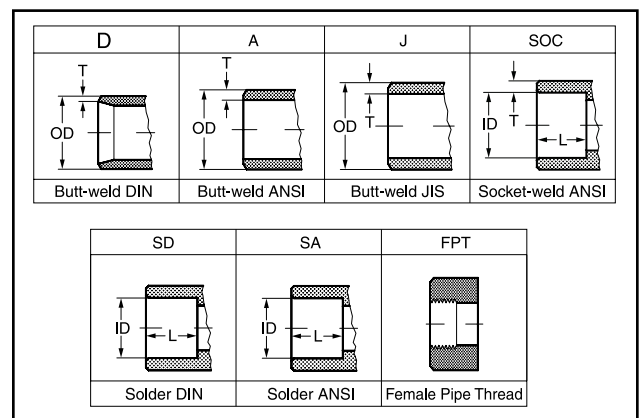
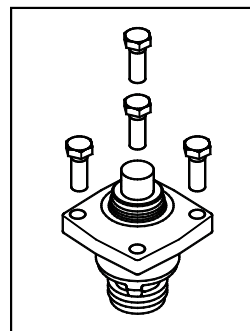

Figure 4 - Valve Body Types



Each body may be fitted with multiple function / top cover to give different capacities.

Figure 5 - Valve Body / Cover Configuration

Type	Valve body size	Kv (m ³ /h)	Cv (USgal/min)
ICM20-A	20	0.6	0.7
ICM20A-33		0.2	0.23
ICM20-B		2.4	2.8
ICM20-C		4.6	5.3
ICM25-A	25	6	7.0
ICM25-B		12	13.9
ICM32-A	32	9	10.4
ICM32-B		17	20
ICM40-A	40	15	17
ICM40-B		26	30
ICM50-A	50	23	27
ICM50-B		40	46
ICM65-B	65	70	81

A magnetic coupled actuator is easily installed. Only two actuators are needed to cover the entire ICM program.

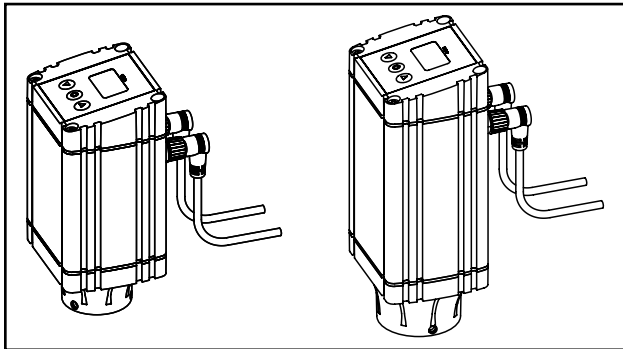

Figure 6 - Magnetic Coupled Actuator

Features (valve)

Designed for Industrial Refrigeration applications for a maximum working pressure of 52 bar / 754 psig.

Applicable to all common refrigerants including R-717, R-744 (CO₂) and non corrosive gases/liquids.

Direct coupled connections.

Connection types include butt weld, socket weld, solder and threaded connections.

Low temperature steel body.

Low weight and compact design.

V-port regulating cone ensures optimum regulating accuracy particularly at part load.

Cavitation resistant valve seat.

Modular Concept

- Each valve body is available with several different connection types and sizes.
- Valve overhaul is performed by replacing the function module.
- Possible to convert ICM motor valve to ICS servo valve.

Manual opening possible via ICAD or Multifunction tool.

PTFE seat provides excellent valve tightness.

Magnet coupling - real hermetic sealing.

Heat cartridge kit ICAD 600 / ICAD 900 available for ICM

Design (valve)

Connections

There is a very wide range of connection types available with ICM valves:

D: Butt weld, DIN (2448)

A: Butt weld, ANSI (B 36.10)

J: Butt weld, JIS (B S 602)

SOC: Socket weld, ANSI (B 16.11)

SD: Solder connection, DIN (2856)

SA: Solder connection, ANSI (B 16.22)

FPT: Female pipe thread (ANSI/ASME B 1.20.1)

Approvals

The ICV valve concept is designed to fulfill global refrigeration requirements.

ICM is CE, UL and CRN approved

For specific approval information, please contact Danfoss.

The ICM valves are approved in accordance with the European standard specified in the Pressure Equipment Directive and are CE marked.

For further details / restrictions - see Installation Instruction.

Valve body and top cover material

Low temperature steel

ICM valves

Nominal bore DN ≤ 25 (1 in.) DN 32-65 mm (1 1/4 - 2 1/2 in.)

Classified for Fluid group I

Category Article 3, paragraph 3 II

Technical data (valve)

Refrigerants

Applicable to all common refrigerants including R-717 and R-744 (CO₂) and noncorrosive gases/liquids.

Use with flammable hydrocarbons cannot be recommended. For further information please contact your local Danfoss sales company.

Temperature range:

Media: -60/+120°C (-76/+248°F).

Pressure

The valve is designed for:

Max. working pressure: 52 bar g (754 psig)

Surface protection

ICM 20-65:

The external surface is zinc-chromated to provide good corrosion protection.

Max. opening pressure differential (MOPD)

- ICM 20-32: 52 bar (750 psi)
- ICM 40: 40 bar (580 psi)
- ICM 50: 30 bar (435 psi)
- ICM 65: 20 bar (290 psi)

Time to move from Closed to Open position or in reverse order with maximum selected speed at ICAD.

ICM 20: 3 Sec. ICM 40: 10 Sec.
ICM 25: 7 Sec. ICM 50: 13 Sec.
ICM 32: 8 Sec. ICM 65: 13 Sec.

Function (valve)

ICM, Industrial Control Motor valves are designed for use with the ICAD, Industrial Control Actuator with Display.

The driving force from the actuator is transferred via a magnetic coupling (a) through the stainless steel top housing (b) and thus eliminates the need for a packing gland. The rotational movement of the magnetic coupling (a) is transferred to a spindle (c) which in turn provides the vertical movement of the cone (d) and PTFE valve plate (e), to open and close the valve. The closing force of the actuator, combined with the PTFE valve plate (e) and cavitation resistant valve seat (f), provides an effective seal to prevent leakage across the valve port, when the valve is in the closed position. To prevent damage to the PTFE valve plate (e) and seat (f) from system debris, it is recommended that a filter is installed upstream of the valve.

Valve inlet pressure (P_1) acting on the underside of the PTFE valve plate (e) also passes through the hollow cone assembly (d) on to the top of the piston (g) and balances the pressure acting on the piston (g). Any trapped liquid across the throttle cone (d) is allowed to equalize down to the valve outlet without affecting the valve performance.

There are two sizes of ICAD actuator that cover the range of valves from ICM 20 to ICM 65. The actuators have a fully weather protected enclosure with none of the moving parts exposed to the environment.

The fast acting actuators and balanced valve design results in the valve being able to move from the fully closed to the fully open position in between 3 to 13 seconds depending on valve size.

The cone (d) includes V-shaped grooves, which provides stable control regulation, particularly at low load conditions. Each valve size has at least two different function modules to select from.

The function modules are designed for different capacities and are designated A and B, (and C in the case of the ICM 20). In general, "A" modules are for liquid applications. The "B" (C) modules have larger capacities than the "A" modules and are mainly for suction applications.

ICAD ACTUATOR

Actuator types ICAD 600 and 900 are dedicated for use with ICM motorized valves. There are only two sizes of ICAD actuators that cover the range of valves from ICM 20 to ICM 65.

The ICAD is controlled via a modulating analogue signal (e.g. 4-20 mA/2-10 V) or a digital ON/OFF signal. ICAD incorporates an advanced MMI (Man Machine Interface), including continuous display of Opening Degree, which gives the user a very advanced and flexible setup procedure that can meet many different applications.

Features (actuator)

- Specifically designed for industrial refrigeration installations
- Advanced and high speed Digital Stepper Motor Technology
- Seven segment LCD display and three programming keys included
- Valve opening degree can be observed continuously.
- Can easily be configured to different applications on-site. (change speed, ON/OFF, modulating valve)
- Open – Close time: 3-13 seconds depending on valve size
- Modulating or ON/OFF operation
- Multiple speed selection during operation
- Logging of old alarms
- Password protection
- Control input signal :
4-20 mA, 0-20 mA, 0-10 V, 2-10 V

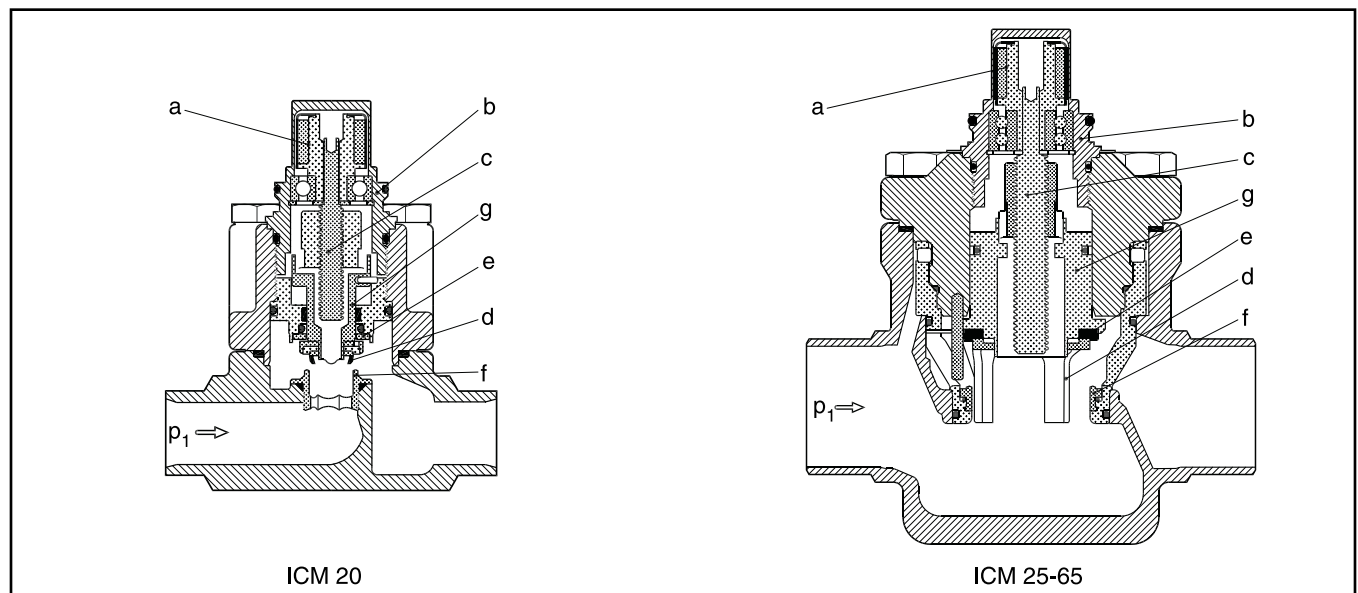

Figure 7 - ICM Industrial Control Motor Valves

- Position feedback : 0-20 mA, 4-20 mA (ICM)
- 3 Digital ON/OFF feedback
- Resolution: 20 micron/step
- (0.02 mm stroke pr. step)
- Total steps: 250 – 1000 depending on size
- Auto Calibration, Neutral zone
- In the event of a power failure, multiple fail safe options are possible. During power failure, ICM can be selected to:
Close ICM,
Open ICM,
Stay in the same position, as when power failure occurs
Go to a specific ICM valve opening degree
- Hermetic magnetic motor
- Enclosure: IP65 ~ NEMA 4
- Approvals: CE, UL, CRN

Technical data (actuator)

ICAD 600 and ICAD 900 can be used together with following Danfoss valves.

ICAD 600	ICAD 900
ICM 20	ICM 40
ICM 25	ICM 50
ICM 32	ICM 65

Materials

Housing
Aluminium

Top part of ICAD PBT thermo plastic

Weight

ICAD 600: 1.2 kg (2.64 lb)
ICAD 900: 1.8 kg (3.96 lb)

Temperature range (ambient)
-30°C/+50°C (-22°F/122°F)

Enclosure

IP 65 (~NEMA 4)

Cable connection

2 cable premounted of 1.8 m length (70.7 in.)

Supply cable

3 × 0.34 mm² (3 × ~22 AWG)
Ø4.4 mm (diameter 0.17")

Control cable

7 × 0.25 mm² (7 × ~24 AWG)
Ø5.2 mm (diameter 0.20")

Electrical data

Supply voltage is galvanic isolated from Input/Output.

Supply voltage: 24 V d.c., + 10% / -15%
Load: ICAD 600: 1.2 A
ICAD 900: 2.0 A

Fail safe supply: Min. 19 V d.c, max. 26.4 V d.c.

Load: ICAD 600: 1.2 A
ICAD 900: 2.0 A

Battery capacity:

For each open/closed cycle

ICAD 600: 8.3 mAh
ICAD 900: 11.1 mAh

Analogue Input - Current or Voltage

Current: 0/4-20 mA
Load: 200 Ω
Voltage: 0/2-10 V d.c.
Load : 10 kΩ

Analogue Output: 0/4-20 mA

Load : ≤ 250 Ω

Digital input - Digital ON/OFF input by means of volt-free contact (Signal/Telecom relays with goldplated contacts recommended) - Voltage input used

ON: contact impedance < 50 Ω
OFF: contact impedance > 100 k Ω

Digital Output - 3 pcs. NPN transistor output

External supply: 5-24 V d.c.

(Same supply as for ICAD can be used, but please note that the galvanically isolated system will then be spoiled)

Output load: 50 Ω
Load: Max. 50 mA

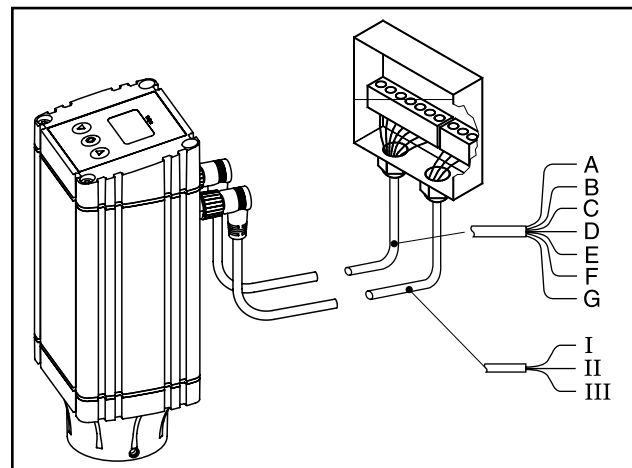

Figure 8 - Premounted Cable Connection

Actuator Cable Connection - Old

Cable connection

Two 1.8 m (70.7 in.) cables premounted

Ref.	Color		Description	
A	White	-	Common Alarm	} Digital Output
B	Brown	-	ICM fully open	
C	Green	-	ICM fully closed	
D	Yellow	-	GND ground	
E	Grey	+	0/4 - 20 mA Input	} Analog In/Output
F	Pink	+	0/2 - 10 V Input	
G	Blue	+	0/4 - 20 mA Output	

NOTE: Color code changed when compared to older color wiring diagram.

I	White	+	Fail safe supply Battery / UPS* 19V d.c.
II	Brown	+	Supply voltage
III	Green	-	24 V d.c.

* Uninterruptable Power Supply

Approvals

CE according to 89/336 EEC (EMC)
Emission : EN61000-6-3
Immunity: EN61000-6-2

UL
CRN

Function (actuator)

The design of ICAD is based on a digital stepper motor technology combined with an advanced MMI (Man Machine Interface), that gives excellent possibilities for having a high degree of flexibility with the same type of ICAD actuator.

At the ICAD display the Opening Degree (0-100 %) of the actual ICM valve installed can be continuously observed.

The advanced menu system will allow several parameters to be adjusted to obtain the required function. Many different parameters can be configured, among these:

Modulating and ON/OFF control

- Analog input
0- 20 mA or 4-20 mA
0-10 V or 2-10 V
- Analog output
0- 20 mA or 4-20 mA
- Automatic or manual control
- Change of ICM valve speed
- Automatic calibration
- Multiple Fail-Safe setup options during power cut

For service all Input and Output signals can be recalled and observed from the ICAD display.

A password protection has been linked to the parameter of entering the correct ICM valve to avoid unintentional and nonauthorized operation.

ICAD can manage and display different alarms. If an alarm has been detected the display will alternate between showing: Actual alarm present and Opening Degree of ICM valve. If more than one alarm is active at the same time the alarm with the highest priority will take preference. The alarm with the highest priority is shown on the display.

All alarms will automatically reset when disappearing.

Previous alarms can be recalled for traceability and service purposes.

Any active alarm will activate the common digital alarm output.

All alarms will automatically reset when disappearing.

ICAD provides two digital output signals to 3rd party control equipment (e.g. PLC) indicating if the ICM valve is completely open or completely closed.

The hermetic magnetic motor coupling makes it easy to dismount the ICAD from ICM valve.

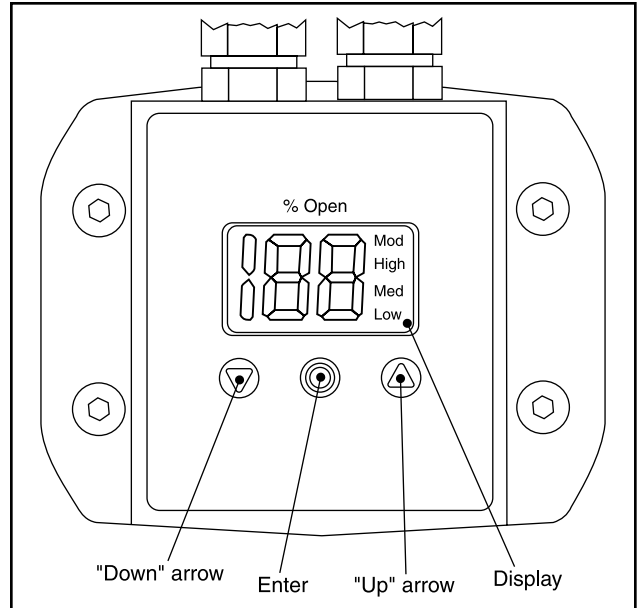

Figure 9 - ICAD with Display

OPERATION OF DANFOSS LIQUID INJECTION VALVE

ICAD (Industrial Control Actuator with Display) is equipped with an MMI (Man Machine Interface) from which it is possible to monitor and change the setting of parameters to adapt the ICAD and the corresponding ICM (Motorized Industrial Control Valve) to the actual refrigeration application.

The setting of parameters is managed by means of the integrated ICAD MMI (Figures 9 and 10) and consists of:

- "Down" arrow push button (Figure 9)
 - Decreases parameter number by 1 at each activation
- "Up" arrow push button (Figure 10)
 - Increases parameter number by 1 at each activation

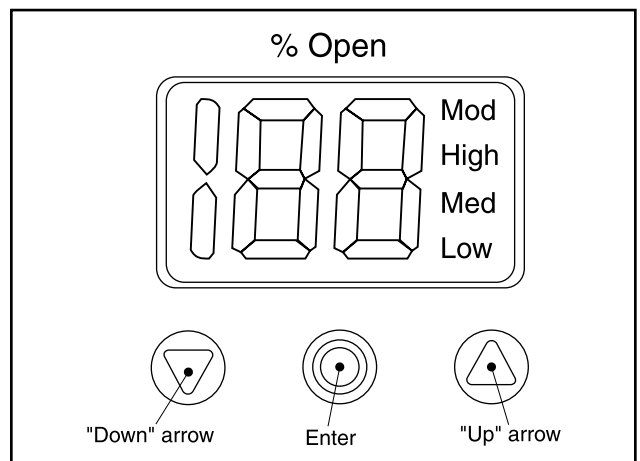

Figure 10 - ICAD Display

- Enter push button (Figure 9)
 - Gives access to the Parameter list by keeping the push

button activated for 2 seconds. A Parameter list example is shown below (parameter **i08**, Figure 11).

- Gives access to change a value once the Parameter list has been accessed.

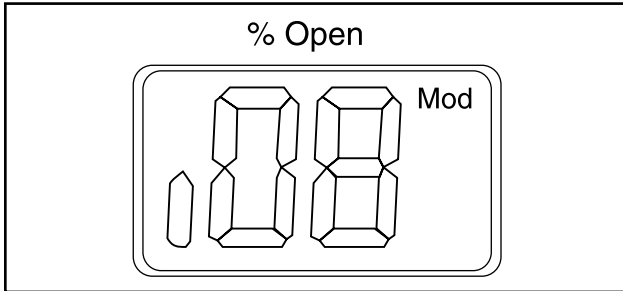

Figure 11 - ICAD Display Showing Parameter

- Acknowledge and save change of value of a parameter.
- To exit from the Parameter list and return to the display of Opening Degree (OD), keep the push button activated for 2 seconds.
- Display (Figure 9)
- Normally the Opening Degree (OD) 0 - 100% of the ICM valve is displayed. No activation of push buttons for 20 seconds means that the display will always show OD (Figure 12).

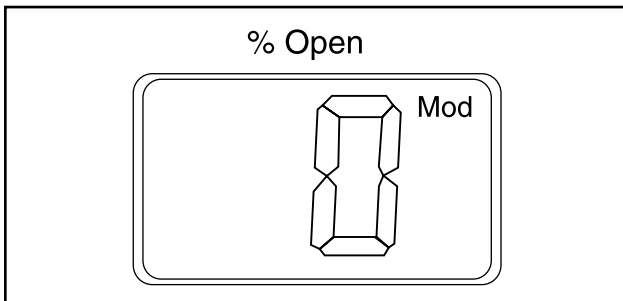

Figure 12 - ICAD Display Showing OD

- Displays the parameter.
- Displays the actual value of a parameter.
- Displays the function status by means of text (Figure 9).
- **Mod** represents that ICAD is positioning the ICM valve according to an analog input signal (Current or Voltage).
- **Low** represents that ICAD is operating the ICM valve like an ON/OFF solenoid valve with low speed according to a digital input signal.
- **Med** represents that ICAD is operating the ICM valve like an ON/OFF solenoid valve with medium speed according to a digital input signal.
- **High** represents that ICAD is operating the ICM valve like an ON/OFF solenoid valve with high speed according to a digital input signal (Figure 13).

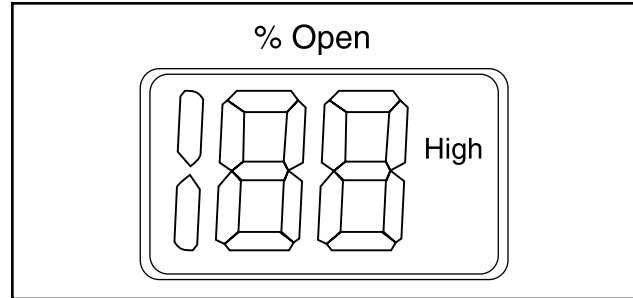

Figure 13 - ICAD Displaying High Speed

Alarms - ICAD can handle and display different alarms.

Description	ICM Alarm Text	Comments
No valve type Selected	A1	At start-up A1 and CA will be displayed
Controller fault	A2	Internal fault inside electronics
All input error	A3	Not active if i01 = 2 or i02 = 2 When i03 = 1 and AI A > 22 mA When i03 = 2 and AI A > 22 mA Or AI A < 2mA When i03 = 3 and AI A > 12V When i03 = 4 and AI A > 12V or AI A < 1 V
LOW voltage of fail-safe supply	A4	If 5 V d.c. < Fail-safe supply < 18 V d.c.
Check Supply to ICAD	A5	If supply voltage < 18 V d.c.

If an alarm has been detected the ICAD display (Figure 9) will alternate between showing Actual alarm and present Opening Degree.

If more than one alarm is active at the same time, the alarm with the highest priority will take preference. **A1** has the highest priority, **A5** the lowest.

Any active alarm will activate the Common Digital Alarm output (Normally Open).

All alarms will automatically reset themselves when they physically disappear.

Old alarms (alarms that have been active, but have physically disappeared again) can be found in parameter **i11**.

Reset to factory setting:

1. Remove the power supply.
2. Activate down arrow and up arrow push buttons at the same time.
3. Connect the power supply.
4. Release down arrow and up arrow push buttons.
5. When the display on ICAD (Figure 9) is alternating between showing: **CA** and **A1** the factory resetting is complete.

Parameter list

Description	Display Name	Min.	Max.	Factory Setting	Unit	Comments (Standard Setting)
ICM OD (Opening Degree)	-	0	100	-	%	ICM valve Opening Degree is displayed during normal operation. Running display value (see j01, j05).
Main Switch	j01	1	2	1	-	Internal main switch 1: Normal operation 2: Manual operation. Valve Opening Degree will be flashing. With the down arrow and the up arrow push buttons the OD can be entered manually.
Mode	jo2	1	2	1	-	Operation mode 1: Modulating - ICM positioning according to Analogue input (see j03) 2: ON/OFF - operating the ICM valve like an ON/OFF solenoid valve controlled via Digital Input. See also j09.
Analog Input signal	j03	1	4	2	-	Type of Analog input signal from external controller 1: 0-20mA 2: 4-20mA 3: 0-10V 4: 2-10V
Speed at ON/OFF and Modulating Mode	j04	1	100	100	%	Speed can be decreased. Max. speed is 100 % Not active when j01 = 2 If j02 = 2, the display will indicate speed in display. Low, Med, and High also means ON/OFF operation. If j04 < = 33, Low is displayed 33 < If j04 < = 66, Med is displayed If j04 > = 67, High is displayed
Automatic calibration	j05	0	1	0	-	Not active before j26 has been operated. Always auto reset to 0. CA will flash in the display during calibration.
Analog Output signal	j06	0	2	2	-	Type of AO signal for ICM valve position 0: No signal 1: 0 - 20mA 2: 4 - 20mA
Fail-safe	j07	1	4	1	-	Define condition at power cut when fail-safe is installed. 1: Close valve 2: Open valve 3: Maintain valve position 4: Go to OD given by j12
Digital Input function	j09	1	2	1	-	Define function when DI is ON (short circuited DI terminals) when j02 = 2 1: Open ICM valve (DI = OFF => Close ICM valve) 2: Close ICM valve (DI = OFF => Open ICM valve)
Password	j10	0	199	0	-	Enter number to access password protected parameters: j26
Old Alarms	j11	A1	A99	-	-	Old alarms will be listed with the latest shown first. Alarm list can be reset by means of activating down arrow and up arrow at the same time for 2 seconds.
OD at powercut	j12	0	100	50	-	Only active if j07 = 4 If fail-safe supply is connected and powercut occurs, ICM will go to entered OD.
ICM configuration	j26	0	6	0	-	NB: Password protected. Password = 11 At first start-up, A1 will flash in display. Enter valve type. 0: No valve selected. Alarm A1 will become active. 1: ICM20 with ICAD 600 2: ICM25 with ICAD 600 3: ICM32 with ICAD 600 4: ICM40 with ICAD 900 5: ICM50 with ICAD 900 6: ICM65 with ICAD 900 You must get number off of Valve Body

Service

OD%	j50	0	100	-	%	ICM valve Opening Degree is displayed during normal operation.
AI [mA]	j51	0	20	-	mA	Analog input signal
AI [V]	j52	0	10	-	V	Analog input signal
AO [mA]	j53	0	20	-	mA	Analog output signal
Digital Input function	j54	0	1	-	-	Digital Input signal
DO Close	j55	0	1	-	-	Digital Output Closed status. ON when OD < 3%
DO Open	j56	0	1	-	-	Digital Output Open status. ON when OD > 97%
DO Alarm	j57	0	1	-	-	Digital Output alarm status. ON when an alarm is detected
MAS mP SW ver.	j58	0	100	-	-	Software version for MASTER Microprocessor
SLA mP SW ver.	j59	0	100	-	-	Software version for SLAVE Microprocessor

Introduction



Figure 14 - Regulating Valves

REG are angle-way and straight-way regulating valves, which act as normal stop valves in closed position.

The valves are designed to meet the strict quality requirements on refrigerating installations specified by the international classification societies and are carefully designed to present favorable flow conditions and accurate linear characteristics.

REG are equipped with vented cap and have internal backseating enabling the spindle seal to be replaced with the valve still under pressure.

Features

Applicable to all common nonflammable refrigerants including R-717 and noncorrosive gases/liquids dependent to sealing material compatibility

Designed to ensure perfect regulation

Internal backseating enables replacement of the spindle seal whilst the valve is active, i.e. under pressure

Easy to disassemble for inspection and possible repair

Max. operating pressure:
REG: 40 bar g (580 psi g)
REG-SS: 52 bar g (754 psig)
(valves for higher operating pressure available on request)

Full temperature range packing gland
-50/+150°C (-58/+302°F)

Low temperature range packing gland for REG-SS
-60/+150°C (-76/+302°F)

Act as a normal stop valve in closed position

Housing and bonnet material is low temperature steel (REG-SS in stainless steel) according to requirements of the Pressure Equipment Directive and other international classification authorities

Exact capacity and setting of the valve can be calculated for all refrigerants by means of "DIRcalc™" (Danfoss Industrial Refrigeration calculation program)

Classification: To get an updated list of certification on the products please contact your local sales representative.

Design

Housing

Made of special, cold resistant steel (stainless steel for REG-SS) approved for low temperature operation.

Connections

Available with the following connections:

Butt-weld DIN (EN 10220)
- DN 6 - 65 (¼ - 2½ in.)

Butt-weld ANSI (B 36.10 Schedule 80)
- DN 6 - 40 (¼ - 1½ in.)

Butt-weld ANSI (B 36.10 Schedule 40)
- DN 50 - 65 (2 - 2½ in.)

Socket weld (ANSI B 16.11)
- DN 15 - 40 (½ - 1½ in.)

Soldering connections (ANSI B 16.22)
- DN 10 - 22 (3/8 - 7/8 in.)

FPT inside pipe thread, NPT (ANSI/ASME B 1.20.1)
- DN 15 - 32 (½ - 1¼ in.)

Valve cone

The valve cone (Figure 15) is designed to ensure perfect regulation. A wide program of valves and various precision cones provide an extensive regulating area, and irrespective of the refrigerant used, it is easy to obtain the correct capacity (see Fig. 1). A cone seal ring provides perfect sealing at a minimum closing momentum.

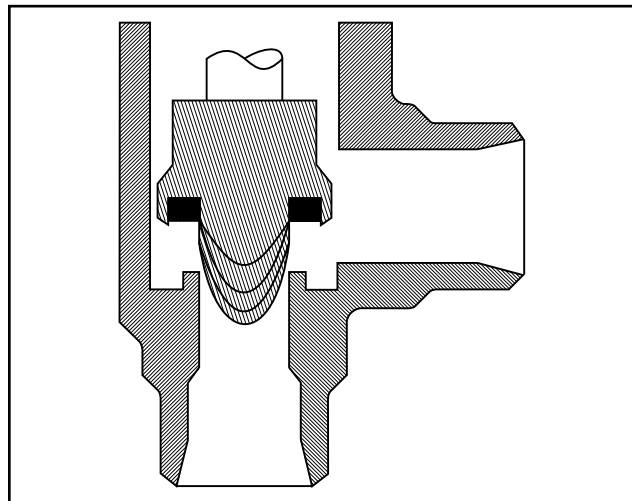

Figure 15 - Valve Cone

The valve cone can be turned on the spindle, thus there will be no friction between the cone and the seat when the valve is opened and closed.

Spindle

Made of polished stainless steel, which is ideal for O-ring sealing.

Packing gland - REG

The "full temperature range" packing gland ensures perfect tightness in the whole range: -50/+150°C (-58/+302°F). The packing glands are equipped with a scraper ring to prevent penetration of dirt and ice into the packing gland.

Packing gland - REG-SS (Stainless steel version):

The stainless steel packing gland comprises a spring-loaded seal packing gland which ensures a perfect tightness in the range -60/+150°C (-76/+302°F). The packing glands are equipped with a scraper ring to prevent penetration of dirt and ice into the packing gland.

Installation

Install the valve with the spindle up or in horizontal position. The flow must be directed towards the cone.

The valve is designed to withstand high internal pressure. However, the piping system in general should be designed to avoid liquid traps and reduce the risk of hydraulic pressure caused by thermal expansion.

For further information refer to installation instruction for REG.

Pressure Equipment Directive (PED)

REG valves are approved according to the European standard specified in the Pressure Equipment Directive and are CE marked.

For further details / restrictions - see Installation Instruction.

REG valves	
Nominal bore	DN32 - 65 (11/4 - 21/2 in.)
Classified for	Fluid group I
Category	II

Refrigerants

Applicable to all common nonflammable refrigerants includ-

ing R-717 and noncorrosive gases/liquids dependent on sealing material compability.

For further information please see installation instruction for REG.

Flammable hydrocarbons are not recommended. For further information please contact your local sales representative.

Temperature range

REG: -50/+150°C (-58/+302°F).

REG-SS: -60/+150°C (-76/+302°F)

Pressure range

Max. operating pressure:

REG: 40 bar g (580 psig).

REG-SS: 52 bar g (754 psig)

Valves for higher working pressure are available on request.

Flow coefficients

Flow coefficients for fully opened valves from kv = 0.17 to 81.4 m3/h (Cv = 0.12 to 57.3 US gal/min)

CONE SIZE	TURNS OPEN														
	2	3	4	5	6	7	8	9	10	11	12	13	14	15	15.5
5	0.68 (0.59)	1.17 (1.01)	1.59 (1.37)	2.01 (1.73)	2.41 (2.07)	2.66 (2.29)									
6	1.20 (1.04)	2.14 (1.84)	3.02 (2.60)	3.87 (3.34)	4.65 (4.01)	5.22 (4.50)									
7	1.76 (1.52)	3.17 (2.74)	4.48 (3.86)	5.75 (4.95)	7.00 (6.03)	7.92 (6.83)									
8	2.31 (1.99)	4.12 (3.55)	5.79 (4.99)	7.37 (6.36)	8.89 (7.66)	10.35 (8.92)	11.65 (10.05)	12.69 (10.94)							
9	3.43 (2.95)	6.38 (5.50)	9.13 (7.87)	11.64 (10.04)	14.05 (12.11)	16.40 (14.14)	18.39 (15.85)	19.79 (17.06)							
10	4.77 (4.11)	8.36 (7.21)	11.85 (10.22)	15.13 (13.05)	18.33 (15.80)	21.60 (18.62)	24.60 (21.20)	26.70 (23.01)							
11	4.35 (3.75)	8.70 (7.50)	13.05 (11.25)	17.40 (15.00)	21.75 (18.75)	26.10 (22.50)	30.45 (26.25)	34.80 (30.00)	39.15 (33.75)	43.50 (37.50)	47.85 (41.25)	52.20 (45.00)			
12	6.53 (5.63)	13.05 (11.25)	19.58 (16.88)	26.10 (22.50)	32.63 (28.13)	39.15 (33.75)	45.68 (39.38)	52.20 (45.00)	58.73 (50.63)	65.25 (56.25)	71.78 (61.88)	78.30 (67.50)	84.83 (73.13)	91.35 (78.75)	94.61 (81.56)



Figure 16 - Liquid Level Transmitters

AKS 41 / 41U liquid level transmitters are used to measure the liquid level in refrigerant vessels.

The AKS 41 / 41U transmits an active 4-20 mA signal which is proportional to the refrigerant liquid level.

The 4-20 mA signal from AKS 41 / 41U can be used in conjunction with a controller to control the refrigerant liquid level.

The Danfoss EKC 347 liquid level controller, is a dedicated controller for use with the AKS 41 / 41U. The 4-20 mA signal from AKS 41 / 41U can be used in conjunction with a controller to control the refrigerant liquid level.

The Danfoss EKC 347 liquid level controller, is a dedicated controller for use with the AKS 41 / 41U.

Special Features

"Plug and Play":
no calibration required.

Service friendly:
electronic head and sensor tube can be separated without emptying the standpipe.

Damping of output signal available.

Improved calibration:
AKS 41 / 41U range/signal output can be adapted to suit the actual application.

AKS 41 / 41U can be supplied with a LED Bargraph indication of Liquid Level, as option

Technical Data

Supply voltage and load:
24 V a.c., -15% / +25%, 50/60 Hz
24 V d.c., ±10%
1.5 W

Signal output:
4-20 mA

Refrigerants:
AKS 41 / 41U supports the following refrigerants:
R-717 (factory setting)
R-404A
R-134a
R-744
R-718 (H₂O) - R-717 and R-718 will give the same AKS 41 output

Temperature range:
- 60/+100°C (-76/+212°F)

NOTE: When used in refrigerant above +60°C (140°F), a Min. Calibration must be carried out after 1 week of operation. Subsequently only a Min. Calibration once a year is needed.

Pressure range:
The AKS 41 / 41U is designed for:
Max. working pressure: 100 bar g (1450 psig)

Connection:
Pipe thread ISO 228/1 - G 1A or 3/4 "

Max. load resistance:
500 ohm

Ambient temperature:
During operation: -25 to +55°C (-13/+131°F).
During transport: -40 to +70°C (-40/+158°F).

Enclosure:
IP65

Connection:
4-pole plug (DIN 43650)

Approvals:
EMC directive 89/336/EEC
EMD directive 92/31/EEC
EN 50081-1
EN 50082-1

Material:
Thread: Stainless steel. AISI 303
Reference pipe: Stainless steel. AISI 304
Inner electrode: PTFE
Electronic top part: Cast Aluminium

Design

Electronic head and sensor tube can be separated without emptying the standpipe. See Figure 12.

Plug can be mounted in 4 different positions.

Function and Factory Setting

The rod consists of two pipes - an inner pipe and an outer pipe. The liquid will flow up between the two pipes and by measuring the electrical capacitance between the pipes, the length of rod immersed in the liquid refrigerant is registered.

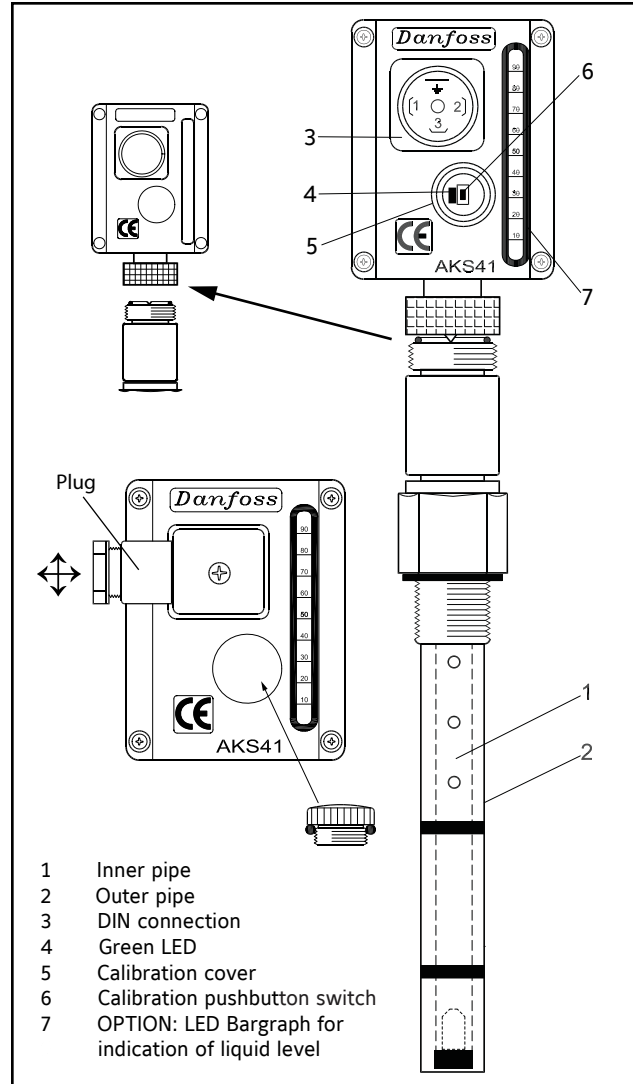

Figure 17 - Liquid Level Transmitter Design

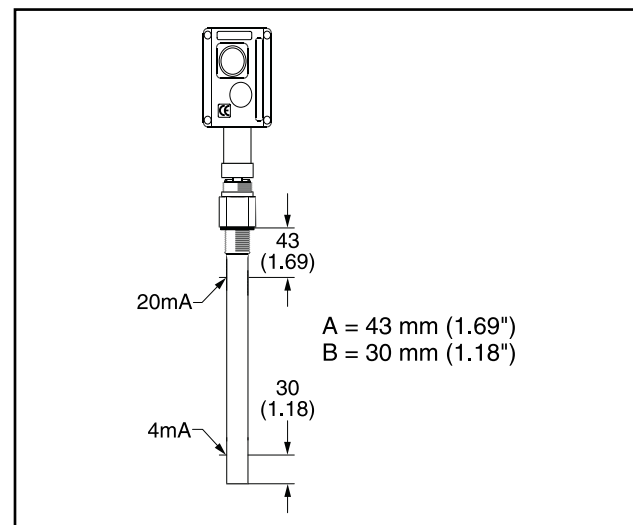

Figure 18 - Liquid Level Transmitter Settings

The signal is transmitted as a current signal from 4 to 20mA (4 mA when the rod does not register liquid - and 20mA when the entire rod is surrounded by liquid).

Factory setting:

The rod comes factory calibrated for R-717 (NH₃), so that it will cover 4 to 20mA throughout the rod's whole measuring range.

Any disturbances in connection with the level measurement will be damped internally.

R-717 (NH₃) / R-718 (H₂O)

It is not necessary to change the settings. The factory setting can be used.

R-404A / R-134a / R-744

Setting for the required refrigerant must be made by following the procedure described in next section.

NOTE: If an alternative refrigerant other than the listed is used, a new Min/max calibration of the level transmitter is required.

Please observe that when used in R-718, over time a lime coating on the outer reference pipe can be experienced. Danfoss recommend removing this lime coating on regular basis.

Setting of Refrigerant

The setting may be carried out before the level transmitter is mounted on the plant.

1. To give in the refrigeration mode setting push the calibration push button and keep it pressed while 24 V a.c. is connected and then release the push button.

NOTE: This sequence must be observed. If the supply voltage is connected before the calibration push button is activated, the signal damping will be changed.

2. Release the calibration push button. Observe the present refrigerant setting and measure the 4-20 mA output signal.
 - 1 flash of Green LED - output signal is ~ 5 mA = R-717 (factory setting)
 - 2 flashes of Green LED - output signal is ~ 6 mA = R-22
 - 3 flashes of Green LED - output signal is ~ 7 mA = R-404A
 - 4 flashes of Green LED - output signal is ~ 8 mA = R-134a
 - 5 flashes of Green LED - output signal is ~ 9 mA = R-744
3. Activate the calibration push button to select required refrigerant.

Each activating will cause AKS 41 / 41U to step to next refrigerant according to below sequence:

- ~ 5 mA = R717 or R718 (factory setting)
- ~ 6 mA = R22
- ~ 7 mA = R404A
- ~ 8 mA = R134a
- ~ 9 mA = R744

4. When the current corresponds to the required refrigerant, wait 10 seconds until the green LED is constant ON (not flashing). This indicates that the required refrigerant has been selected.

5. To leave the setting mode isolate the voltage supply to the level transmitter.

Go through step 1, 2 and 5 if you wish to control the setting.

Signal Damping

Signal damping is factory-set at 15 seconds. This setting can be altered by activating the calibration switch (see Figure 17).

The setting range is 1 to 120 seconds. Settings can also be made while the system is operating.

Procedure:

1. Connect the supply voltage.
2. Push the calibration push button once for each second by which you want to increase the damping.

Example:

1. push ⇒ 1 sec.
2. pushes ⇒ 2 sec.
- etc.
120. pushes ⇒ 120 sec.
121. pushes ⇒ 120 sec.

Ten (10) seconds after the last push, the value will be saved in the memory and the green LED will start flashing again.

After 10 seconds, a further push will start 1-second signal damping again. (If the damping setting is set too high, restart the procedure from step 1).

Calibration of the AKS 41 / 41U

AKS 41 / 41U will not need calibration if it is installed in refrigerant which is defined in AKS 41 / 41U and the ordered length corresponds to actual refrigerant measuring range.

Calibration of the AKS 41 / 41U may be relevant:

If the default setting does not fit and the max. /min. calibration points have to be adjusted.

If the AKS 41 / 41U is used in a refrigerant, not already defined in AKS 41 / 41U.

If the electronic head is replaced on an existing AKS 41 / 41U sensor.

Usually the min. calibration point is chosen to be 4 mA and the max. calibration point to be 20 mA, but it is also possible to calibrate the transmitter at other calibration points.

This opportunity can be useful when calibrating on a plant with no possibility of bringing the level to the limit points.

Default factory setting is:

0% (AKS 41 / 41U free of liquid) output signal: 4 mA
100% (AKS 41 / 41U fully covered by liquid) output signal: 20 mA

The max. /min. points can be set to any value.

Adjusting the min. /max. calibration points:

Min. calibration:

1. Bring the refrigerant liquid level to desired minimum level.
2. Press the calibration push button and keep it activated in approx. 5 seconds, until green LED stops flashing.
3. Activate, within the next 10 seconds, the calibration push button once (If calibration push button is not activated within 10 seconds, it will automatically leave calibration mode and return to normal operation)

Green LED is ON in a few seconds, and then flashing.

Output is now 4 mA and AKS 41 / 41U is in normal operation

Max. calibration:

1. Bring the refrigerant liquid level to desired maximum level.

2. Press the calibration push button and keep it activated in approx. 5 seconds, until green LED stops flashing.
3. Activate, within the next 10 seconds, the calibration push button twice (If calibration push button is not activated within 10 seconds, it will automatically leave calibration mode and return to normal operation)

Green LED is ON in a few seconds, and then flashing.

Output is now 20 mA and AKS 41 / 41U is in normal operation

Min. calibration when minimum refrigerant level must be different from 4 mA:

1. Bring the refrigerant liquid level to desired minimum level.
2. Press the calibration push button and keep it activated in approx. 5 seconds, until green LED stops flashing.
3. Activate, within the next 10 seconds, the calibration push button once and keep it activated. (If calibration push button is not activated within 10 seconds, it will automatically leave calibration mode and return to normal operation)
4. Observe the output mA signal increasing fast starting at 4 mA.
5. Release the calibration push button when the output signal is approx. 0.5 mA from the desired point.
6. All the next activations will increase the output signal by approx. 0.05 mA
7. Approx. 10 seconds after the latest activation the LED starts flashing
8. Output now corresponds to the value measured at the latest activation.

Max. calibration when maximum refrigerant level must be different from 20 mA:

1. Bring the refrigerant liquid level to desired maximum level.
2. Press the calibration push button and keep it activated in approx. 5 seconds, until green LED stops flashing.
3. Activate, within the next 10 seconds, the calibration push button twice and keep it activated. (If calibration push button is not activated within 10 seconds, it will automatically leave calibration mode and return to normal operation)
4. Observe the output mA signal decreasing fast starting at 20 mA.
5. Release the calibration push button when the output signal is approx. 0.5 mA from the desired point.
6. All the next activations will decrease the output signal by approx. 0.05 mA
7. Approx. 10 seconds after the latest activation the LED starts flashing
8. Output now corresponds to the value measured at the latest activation.

Reset To Factory Setting

AKS 41 / 41U can always be reset to factory setting regardless of any revised calibration values.

1. Press the calibration push button and keep it activated in min. 20 seconds, until green LED starts flashing.
2. Release the calibration push button.
3. When LED starts flashing, reset to factory setting is completed.

AKS 41 / 41U is now operating according to the factory settings.

Green LED Indication

When voltage is applied the LED will flash rapidly as many times as it has been calibrated through its lifetime.

Please note: The current mA output is activated as soon as the flashing sequence has changed from rapid to slowly flashing.

Normal operation:

At normal operation the Green LED will be flashing slowly.

Generally the Green LED is ON every time calibration push button is activated.

Calibration mode

In calibration mode (Press the calibration push button and keep it activated in approx. 5 seconds) the Green LED is OFF.

Change of refrigerant

In refrigeration mode setting (Push the calibration push button and keep it pressed while 24 V a.c. is connected and then release the push button) the green LED is OFF until the push button is released.

After this the green LED will flash according to the type of refrigerant.

When the refrigerant has been selected, the green LED is constantly ON.

Instructions

Necessary connections

Terminals:

- 25-26 Supply voltage 24 V a.c.
- 15-16 Signal from level transmitter type AKS 41 or
- 14-16 Signal from transmitter 0-10V
- 23-24 Expansion valve type AKV or AKVA or
- 2-5 Expansion valve type: ICM with ICAD
- 1-2 Switch function for start/stop of regulation. If a switch is not connected, terminals 1 and 2 must be shortcircuited.

Application dependent connections

Terminal:

- 12-13 Alarm relay
There is connection between 12 and 13 in alarm situations and when the controller is dead
- 8-10 Relay for lower level limit. There is connection between 8 and 10 when the set value is passed
- 9-10 Relay for upper level limit. There is connection between 9 and 10 when the set value is passed
- 17-18 ICM valve feedback signal from ICAD 0/4-20 mA
- 19-21 Current signal or
- 20-21 Voltage signal from other regulation (for external reference displacement)
- 3-4 Data communication
Mount only, if a data communication module has been mounted.

It is important that the installation of the data communication cable be done correctly.

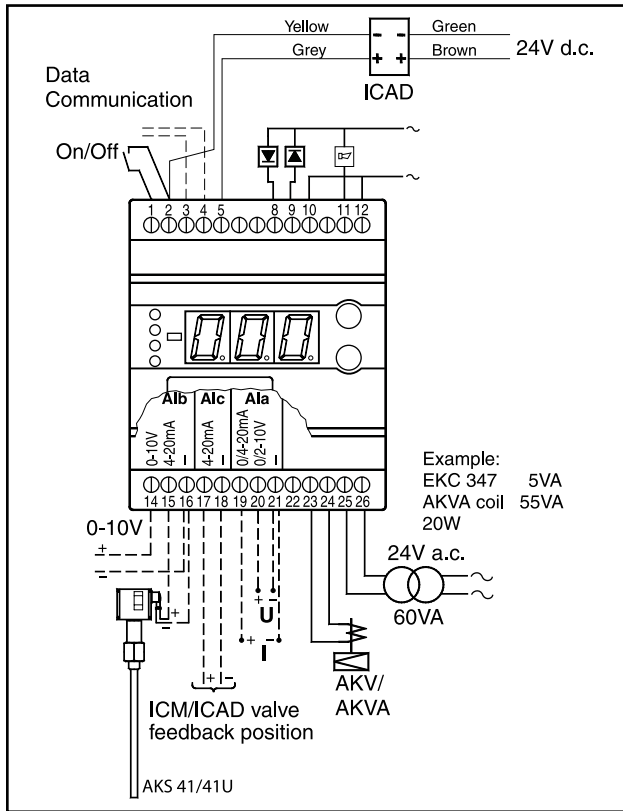

Figure 19 - Liquid Level Controller Connection

Liquid Level Controller - ON/OFF Application. Open/Close solenoid valve with coil 110 V

ON/OFF application
Beside of modulating PI control EKC 347 does also support ON/ OFF operation with hysteresis.

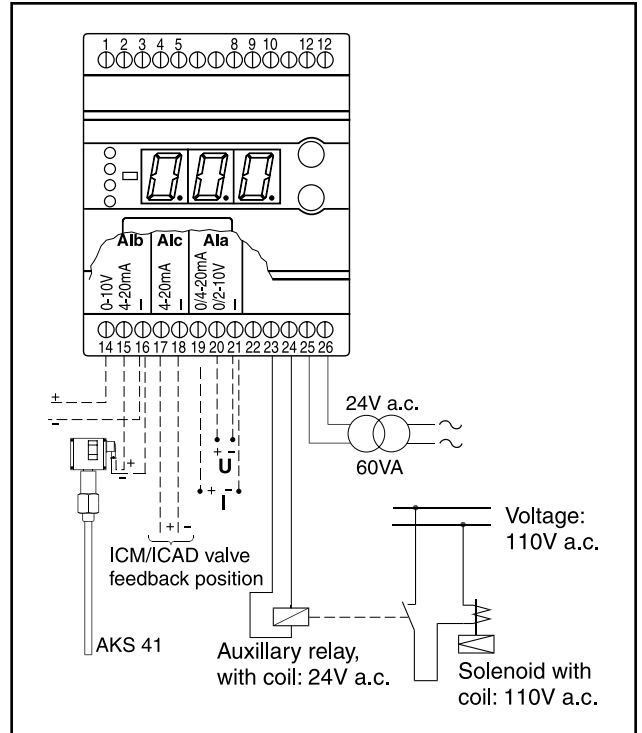

Figure 21 - ON/OFF Application. Open/Close solenoid valve with coil 110 V

To ensure this operation:
P.Band must be (n04)=0%/OFF
Hysteresis is given by (n34)
Setpoint as normal procedure. (pushing the upper/lower buttons simultaneously)
Low or High side system. (n35)

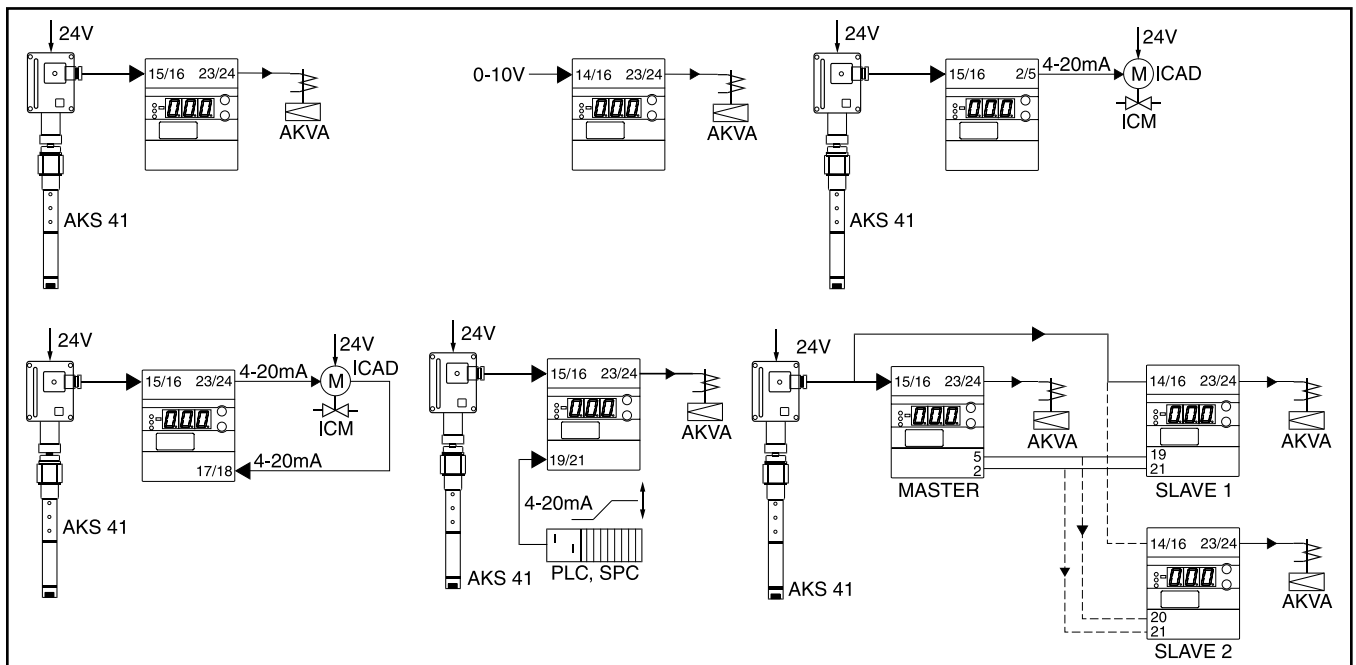
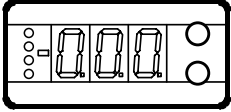

Figure 20 - Liquid Level Controller Connection Examples

Operation

Display

The values will be shown with three digits, and after an operation the controller will return to its standard mode and show the measured liquid level.



Light-emitting diodes (LED) on front panel

There are LED's on the front panel which will light up when the corresponding relay is activated.



The upper LED will indicate the valve's opening degree. A short pulse indicates a slow liquid flow and a long pulse a fast liquid flow.

The three lowest LED's will flash, if there is an error in the regulation.

In this situation you can upload the error code on the display and cancel the alarm by giving the uppermost button a brief push.

The buttons

When you want to change a setting, the two buttons will give you a higher or lower value depending on the button you are pushing. But before you change the value, you must have access to the menu. You obtain this by pushing the upper button for a couple of seconds - you will then enter the column with parameter codes. Find the parameter code you want to change and push the two buttons simultaneously. When you have changed the value, save the new value by once more pushing the two buttons simultaneously.

-  Gives access to the menu (or cuts out an alarm)
-  Gives access to changes
-  Saves a change

Examples of operations

Set reference

1. Push the two buttons simultaneously
2. Push one of the buttons and select the new value
3. Push both buttons again to conclude the setting

Set one of the other menus

1. Push the upper button until a parameter is shown
2. Push one of the buttons and find the parameter you want to change
3. Push both buttons simultaneously until the parameter value is shown
4. Push one of the buttons and select the new value
5. Push both buttons again to conclude the setting

Menu Survey

SW = 1.1x

Function	Parameter	Frick Setting	Min.	Max.	Fac. Setting
Normal display					
Read the measured liquid level	-	-		%	50
If you wish to see the actual opening degree, give the lower button a brief push	-	-		%	0
If you wish to set the required setpoint you obtain access by pushing both buttons simultaneously	-	-	0%	100%	100
Level control					
External contribution to the reference. Cf. also o10. Value is set in %-points.	r06	-	-100	100	0
Start / stop of level control	r12	ON	OFF/0	ON/1	1
Alarm					
Pump ON-OFF, liquid level (Upper level limit)	A01	20%	0%	100%	85
High level alarm or positive stop feed (Lower level limit)	A02	55%	0%	100%	15
Pump on delay (Time delay for upper level limit)	A03	20 s	0 s	999 s	50
High level alarm or positive stop delay (Time delay for lower level limit)	A15	10 s	0 s	999 s	10
Low level alarm limit, liquid level	A16	25%	0 s	999 s	20
Low level alarm, on delay	A17	10 s	0 s	999 s	0
High level & low level alarm configuration The level alarm is linked to: 0: Rising level (higher level than A16) 1: Falling level (lower level than A16) 2: Same function as if A18=0. When A2 alarm is generated and Relay for lower level limit, gives OFF signal (cutout). 3: Same function as if A18=1. When A2 alarm is generated and Relay for lower level limit, gives OFF signal (cutout).	A18	1	0	3	0
Alarm limit relay Function for Alarm relay when A1, A2 or A3 alarms are detected. 0: Alarm relay to be activated when A1 or A2 or A3 are detected. 1: Alarm relay only to be activated when A3 is detected.	A19	1	0	1	0
Regulating parameters					
Proportional band - "OFF" when o09 is set to 3	n04	OFF	0%/Off	200%	30
I: Integration time Tn	n05	-	60	600/Off	400
Valve Cycle Time - Period time (only if AKV/A valve is used)	n13	6 s	3 s	10 s	6
Max. opening degree	n32	-	0%	100%	100
Min. opening degree	n33	-	0%	100%	0
Neutral zone - "10" when o09 is set to 3 (only for ICM valve)	n34	10	2%	25%	2
Valve Close on Liquid Rise - Definition of regulating principle Low: On the low-pressure side (valve closes when liquid level is rising) High: On the high-pressure side (valve opens when liquid level is rising)	n35	Low	Low/0	Hig/1	0
Miscellaneous					
Controller's address	o03*	-	0	60	0
ON/OFF switch (service-pin message)	o04*	-	OFF	ON	
Valve Configuration, AKV/A Output Define valve and output signal: 1: ICM. AO: 4-20 mA 2: ICM. AO: 0-20 mA 3: AKV/A, AO: 4-20 mA 4: AKV/A, AO: 0-20 mA Or if a master/slave function is used: 5: AKV/A, MASTER 6: AKV/A, SLAVE 1/1. AO:4-20 mA 7: AKV/A, SLAVE 1/1. AO:0-20 mA 8: AKV/A, SLAVE 1/2. AO:4-20 mA 9: AKV/A, SLAVE 1/2. AO:0-20 mA 10: AKV/A, SLAVE 2/2. AO:4-20 mA 11: AKV/A, SLAVE 2/2. AO:0-20 mA 12: AKV/A, SLAVE 1/1. AO:4-20 mA- AO always updated 13: AKV/A, SLAVE 1/1. AO:0-20 mA- AO always updated 14: AKV/A, SLAVE 1/2. AO:4-20 mA- AO always updated 15: AKV/A, SLAVE 1/2. AO:0-20 mA- AO always updated 16: AKV/A, SLAVE 2/2. AO:4-20 mA- AO always updated 17: AKV/A, SLAVE 2/2. AO:0-20 mA- AO always updated	o09	3	1	17	1
Define the input signal on terminals 10, 20, 21 (external reference displacement) 0: OFF 1: 4-20 mA 2: 0-20 mA 3: 2-10 V 4: 0-10 V	o10	-	0	4	0
Language 0=English, 1=German, 2=French, 3=Danish, 4=Spanish, 5=Italian, 6=Swedish. When you change the setting you must also activate o04.	o11*	-	0	6	0
Set supply voltage frequency	o12	60	0/50Hz	1/60Hz	0

Continued from previous page

Function	Parameter	Frick Setting	Min.	Max.	Fac. Setting
Selection of parameter for display and AO (except from when o09=1,2 or 5) If o34 = 0: 0: Liquid level is show 1: Valve's opening degree OD will be shown If o34 = 1: 0: Liquid level is show 1: The ICM valve position feed back signal [%] will be shown	o17	-	0	1	0
Manual control of outputs: OFF: No manual control 1: Upper level relay put in pos. ON 2: Lower level relay put in pos. ON 3: AKV/A output put in pos. ON 4: Alarm relay activated (cut out)	o18	-	OFF	4	0
Input Signal on 15 & 16, 4 to 20 mA: Define input signal (level signal) on terminals 14, 15, 16 0: OFF 1: 4-20 mA 2: 0-10 V (also set the voltage values in the next two menus) Read functional description if the connection used is a master/slave function.	o31	1	0	2	1
Define input signal's lower value for terminal 14, if required	o32	-	0.0 V	4.9 V	4.0
Define input signal's upper value for terminal 14, if required	o33	-	5.0 V	10 V	6.0
Define input signal on terminals 17-18 0: Not used 1: ICM mA feedback signal from ICAD connected 2: Not used	o34	-	0	2	0
Service					
Read liquid level	u01				%
Read liquid level reference	u02				%
Read external contribution to the reference	u06				mA
Read external contribution to the reference	u07				V
Read current signal on the analog output	u08				mA
Read status of input	u10				
Read valve's opening degree	u24				%
Read level signal	u30				mA
Read level signal	u31				V
Read signal from ICM/ICAD	u32				mA
Read signal from ICM/ICAD converted into %	u33				%

* This setting will only be possible if a data communication module has been installed in the controller.

Factory setting

If you need to return to the factory-set values, it can be done in this way:
- Cut out the supply voltage to the controller
- Keep both buttons depressed at the same time as you reconnect the supply voltage

Error Messages

The controller can give the following messages:		
E1	Error message	Errors in the controller
E12		The external reference contribution is outside the range
E21		Level signal outside the range (1)
E22		Signal from ICM/ICAD outside the range
A1	Alarm message	Upper level limit reached
A2		Lower level limit reached
A3		Alarm level limit reached

1 - If E21 is detected. EKC 347 will force the valve to close or open the valve depending of n35

If Low pressure has been selected. (n35=0)

The valve is forced to fully closed - however if Min. Opening Degree (n33) is higher than 0, the valve will open to the value of n33

If High pressure has been selected. (n35=1)

The valve is forced to fully open - however if Max. Opening Degree (n32) is lower than 100, the valve will open to the value of n32

MAINTENANCE



THIS SECTION MUST BE READ AND UNDERSTOOD BEFORE ATTEMPTING TO PERFORM ANY MAINTENANCE OR SERVICE TO THE UNIT.

OIL REMOVAL

Frick Recirculator Packages have a separate ASME coded oil pot for oil removal from the low side of the refrigerant system. To remove oil from the oil pot, please follow these recommended procedures (also see Figure 22):

1. Close oil/liquid inlet valve (HV-1).
2. Open vent valve (HV-2) if not already open.
3. Let ambient temperature warm oil pot for minimum of one hour. Low temperature systems may take longer.



NEVER, EVER SPRAY HOT OR COLD WATER OR USE A HEATER (BLOWER) ON AN OIL POT OR A REFRIGERANT PUMP TO REMOVE ICE OR FROST. THIS MAY CAUSE THE OIL POT OR PUMP TO EXPLODE (EVEN THOUGH THEY HAVE RELIEF DEVICES) WHICH COULD RESULT IN SERIOUS INJURY OR DEATH.

4. After sufficient time has elapsed, close vent valve (HV-2).
5. Open oil drain isolation valve (HV-3).



ALWAYS WEAR A FACE SHIELD AND CHEMICAL GOGGLES AND HAVE A GAS MASK READILY AVAILABLE

WHEN DRAINING OIL FROM THE OIL POT OR REPAIRING A PUMP OR REPAIRING ANY ITEM ON THE RECIRCULATOR. ACCIDENTAL EXPOSURE COULD RESULT IN SERIOUS INJURY OR DEATH.

6. Slowly and carefully open hand-operated spring return valve (HV-4) and hold valve open until as much oil as pos-

sible has drained from oil pot. **NOTE: Oil and refrigerant should be drained into a proper container and disposed of in accordance with Federal, State, and Local regulations.**

NOTE: In many systems, the suction pressure may be below atmospheric pressure. This will prevent the oil from draining. In systems with low suction pressure, proceed as follows: Observe the melting frost and when it is about 2/3 melted, close the vent valve. The remaining refrigerant will now build sufficient pressure so that the oil will drain freely after all of the frost is melted.

7. After oil is removed, close oil drain isolation valve (HV-3) first. Then close hand-operated spring return valve (HV-4).

8. Open vent valve (HV-2).

9. Open oil/liquid inlet valve (HV-1).

NEVER CLOSE HV-1, HV-2, AND HV-4 AT THE SAME TIME AND LEAVE UNATTENDED. Refrigerant entrained with the



oil may vaporize causing a pressure increase in the oil pot. This may result in an uncontrolled loss of refrigerant and oil which could cause serious injury or death.



Uncontrolled release of refrigerant can cause serious injury or death.

When CLOSING isolation valves, consideration shall be given to pressure rise resulting from hydrostatic expansion due to temperature rise of liquid refrigerant trapped between CLOSED valves. Trained technicians are required to purge refrigerant.

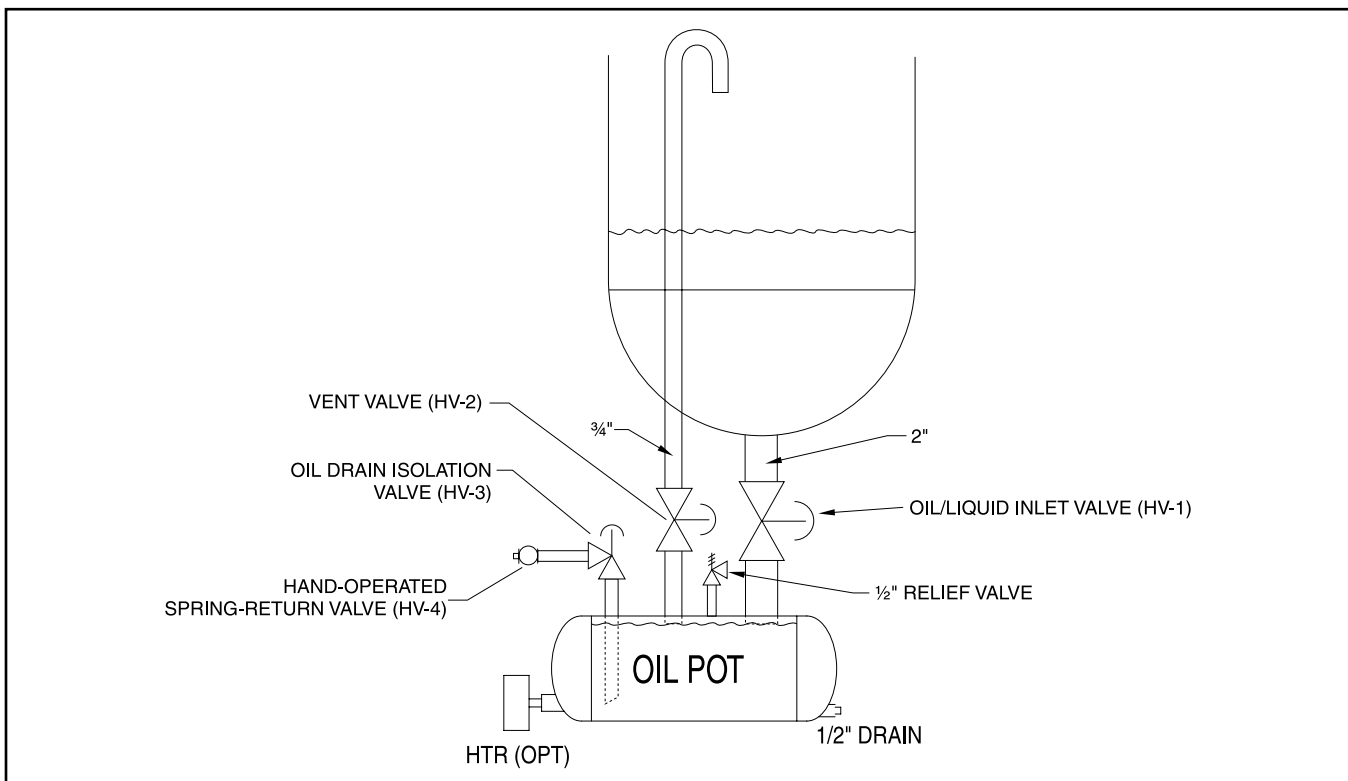

Figure 22 - Removing Oil from the Recirculator Unit

SAFETY RECOMMENDATIONS

- Always keep drain and purge valves plugged.
- Keep the pump discharge pressure at its proper setpoint by adjusting the liquid bypass valve.
- **NEVER SPRAY HOT OR COLD WATER OR USE A HEATER (BLOWER) ON AN OIL POT OR A REFRIGERANT PUMP TO REMOVE ICE OR FROST. THIS MAY CAUSE THE OIL POT OR PUMP TO EXPLODE EVEN THOUGH THEY HAVE RELIEF DEVICES.**
- If the pumps continually cavitate and you cannot prevent this from happening, call the Johnson Controls-Frick Service Department for instructions. Each maintenance person must sign off with the plant engineer that they read and understood the manufacturers instructions before repairing an ammonia pump.
- **ALWAYS WEAR A FACE SHIELD AND CHEMICAL GOGGLES AND HAVE A GAS MASK READILY AVAILABLE WHEN DRAINING OIL FROM THE OIL POT OR REPAIRING A PUMP OR REPAIRING ANY ITEM ON THE RECIRCULATOR PACKAGE.**

TROUBLESHOOTING

Frick Recirculator Packages have been designed employing the latest technology. They are designed specifically to minimize cavitation. However, if there is a sudden drop in pressure of just a few pounds, the liquid in the recirculator will start to boil forming bubbles which could get into the pump suction and cause some temporary cavitation. Most of these sudden drops in recirculator pressure are caused by poor adjustment of the hand expansion valve on the liquid feed to the recirculator. If the expansion valve is wide open when liquid is fed into the recirculator, a large amount of liquid is introduced, thus raising the pressure and causing bubbles. The compressor(s) then load up and pull the recirculator pressure down causing more bubbles to form and the pump to cavitate.

THE HAND EXPANSION VALVE FEEDING THE RECIRCULATOR MUST BE ADJUSTED SO THAT THE SOLENOID IS OPEN (REFRIGERANT IS BEING FED INTO THE RECIRCULATOR) AT LEAST 85% OF THE TIME.

PROBLEM	SOLUTION
<p>1. High-level cutout occurs.</p> <p>2. Low-level alarm does not function and low-level switch does not shut down system and pumps.</p> <p>3. Pumps cavitate continually.</p>	<ul style="list-style-type: none"> • Check float switch function. • Check the defrost system. Several sets of large coils may be defrosting at the same time. Spread them apart and check defrost times. • One large evaporator is defrosting. Check the defrost time. It may be too long. • Check hot gas solenoids on defrost systems. If they leak, excessive liquid will accumulate in the coil(s), thus causing flood-back on defrost. • The level column may be oil logged. Drain column. • Check liquid-feed solenoid valve. • Check the level controller function. • Check liquid-feed strainer (may be clogged). • Check liquid solenoid. • Hand expansion valve on recirculator liquid feed not properly adjusted. • Low-level alarm and cutout may be improperly located. Adjust setpoint. • The level column may be oil logged. Drain column. • Check all stop valve positions. • Pump bypass valve may not be set properly. • Check hand expansion valves on all evaporators. Some may have been opened fully. • If problems continue, call the Frick Service Department.

VERTICAL RECIRCULATOR PACKAGE WITH CORNELL PUMPS

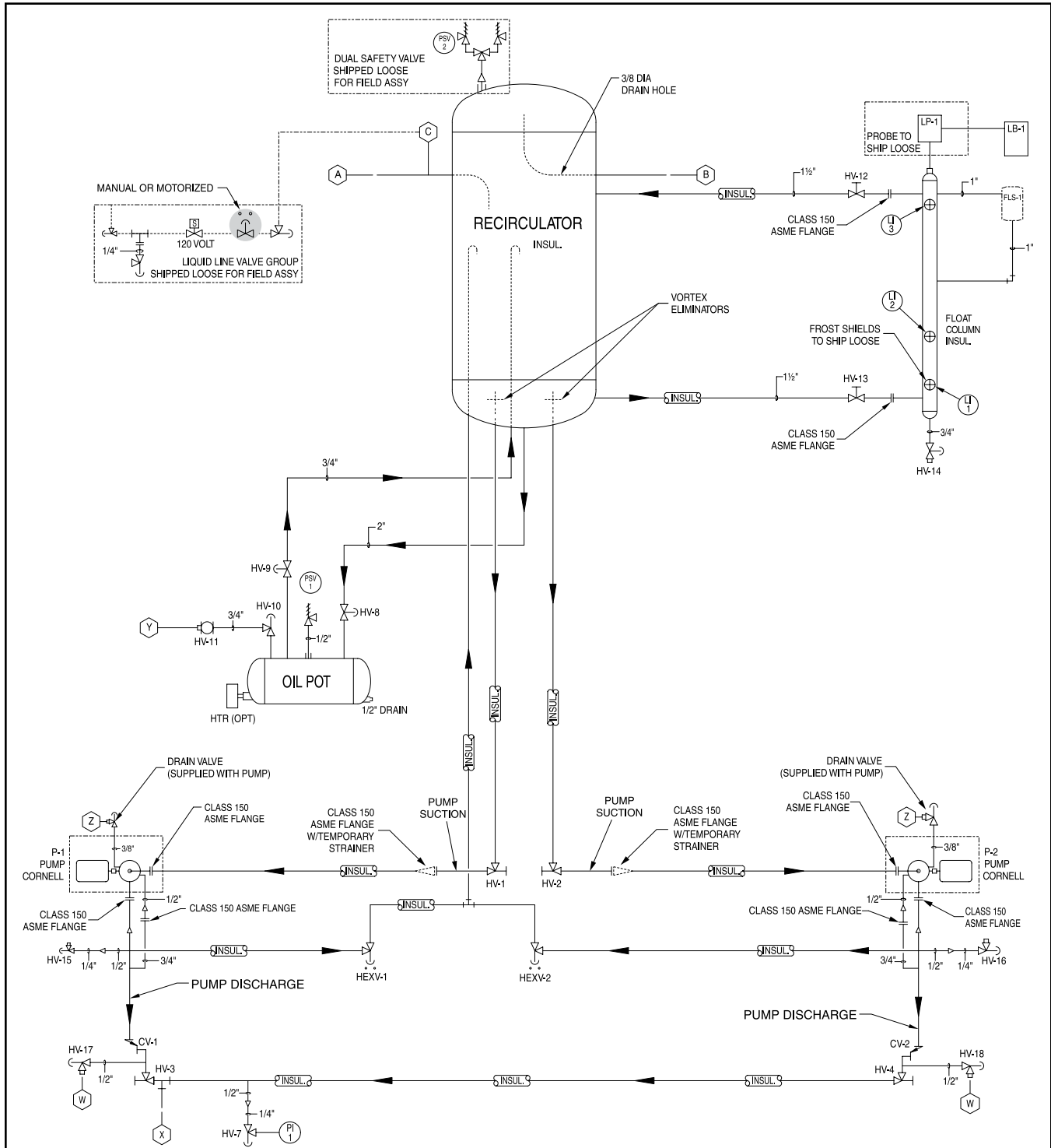

LEGEND FOR P and I DIAGRAMS

- CV Check Valve
- HV Hand Valve
- HEXV Hand Expansion Valve
- P Pump
- LI Level Indicator, H1100C-R
- PI Pressure Indicator
- LP Liquid Level Probe
- LB Liquid Level Control
- FLS Float Switch
- HTR Immersion Heater

- ASME SAFETY RELIEF VALVES**
- PSV-1 Single Relief Valve
 - PSV-2 Double Relief Valve
- LIQUID LEVEL CONTROL**
- LP-1 Probe
 - LB-1 Controller

- CUSTOMER CONNECTIONS**
- A Wet Return
 - B Gas Outlet
 - C Liquid Makeup
 - W Drain / Purge
 - X Pump Discharge
 - Y Oil Pot Drain
 - Z Pump Drain / Purge

HORIZONTAL RECIRCULATOR PACKAGE WITH CORNELL PUMPS

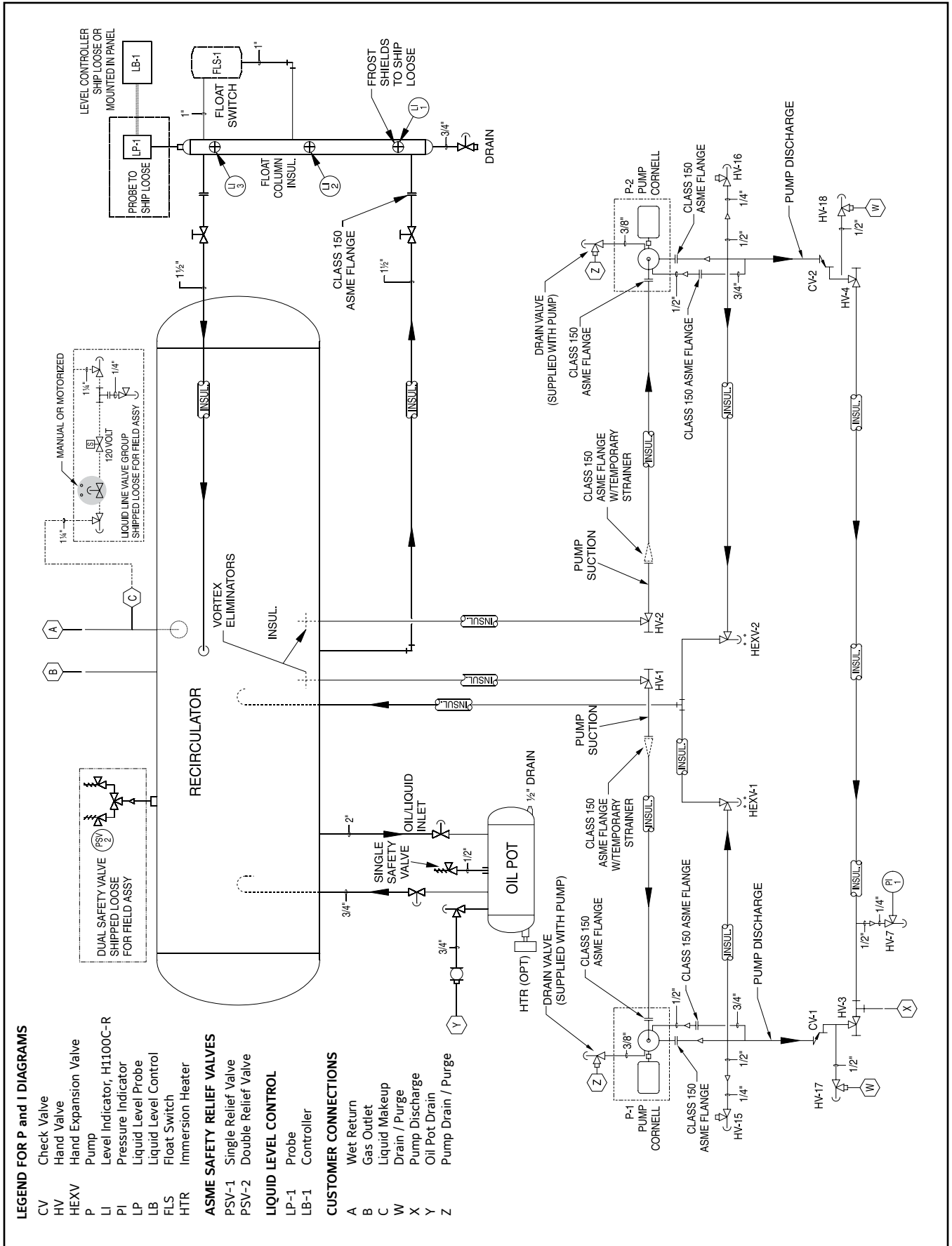

VERTICAL RECIRCULATOR PACKAGE WITH TEIKOKU PUMPS

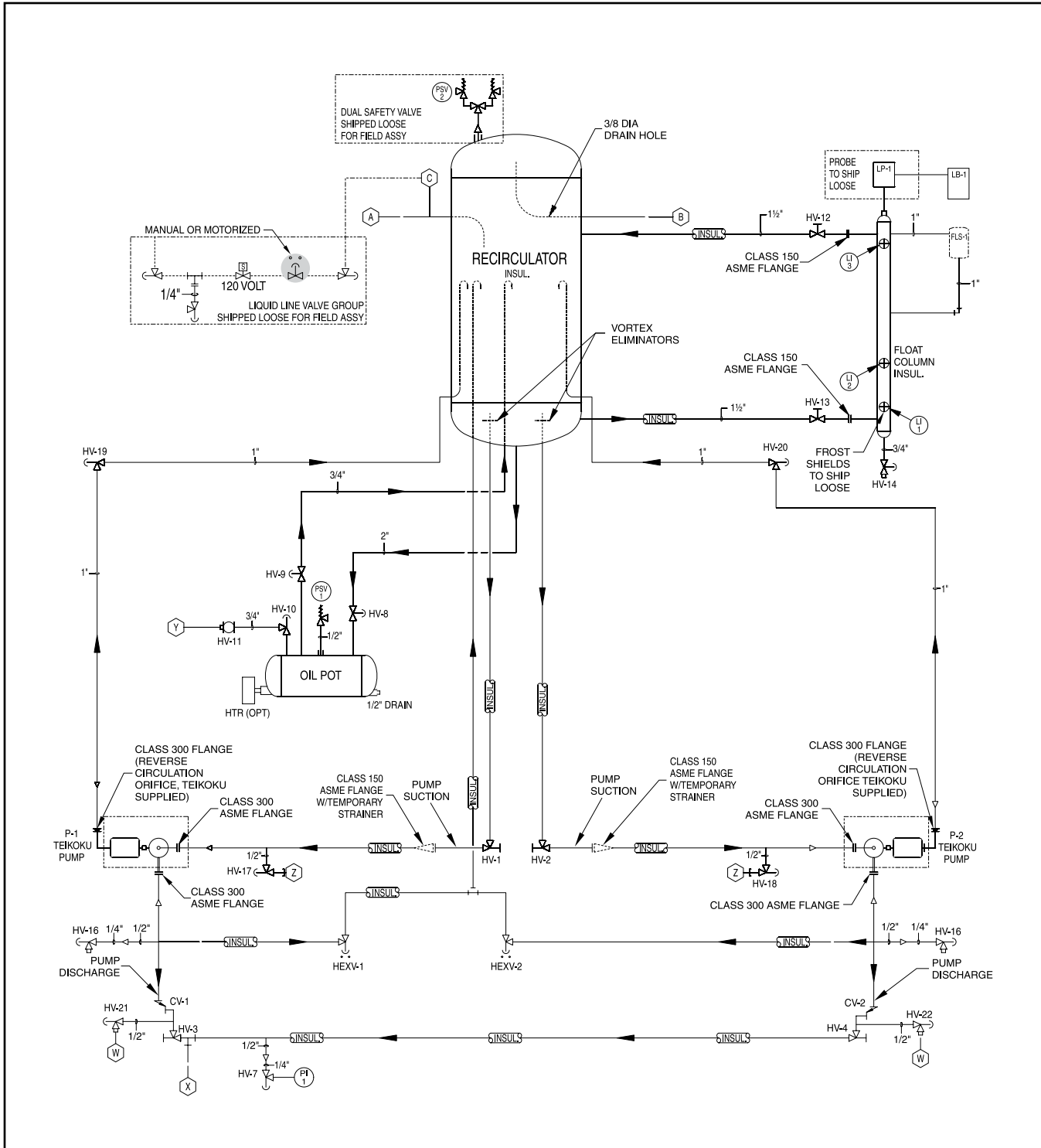

LEGEND FOR P and I DIAGRAMS

- CV Check Valve
- HV Hand Valve
- HEXV Hand Expansion Valve
- P Pump
- LI Level Indicator, H1100C-R
- PI Pressure Indicator
- LP Liquid Level Probe
- LB Liquid Level Control
- FLS Float Switch
- HTR Immersion Heater

- ASME SAFETY RELIEF VALVES**
- PSV-1 Single Relief Valve
- PSV-2 Double Relief Valve
- LIQUID LEVEL CONTROL**
- LP-1 Probe
- LB-1 Controller

- CUSTOMER CONNECTIONS**
- A Wet Return
- B Gas Outlet
- C Liquid Makeup
- W Drain / Purge
- X Pump Discharge
- Y Oil Pot Drain
- Z Pump Drain / Purge

HORIZONTAL RECIRCULATOR PACKAGE WITH TEIKOKU PUMPS

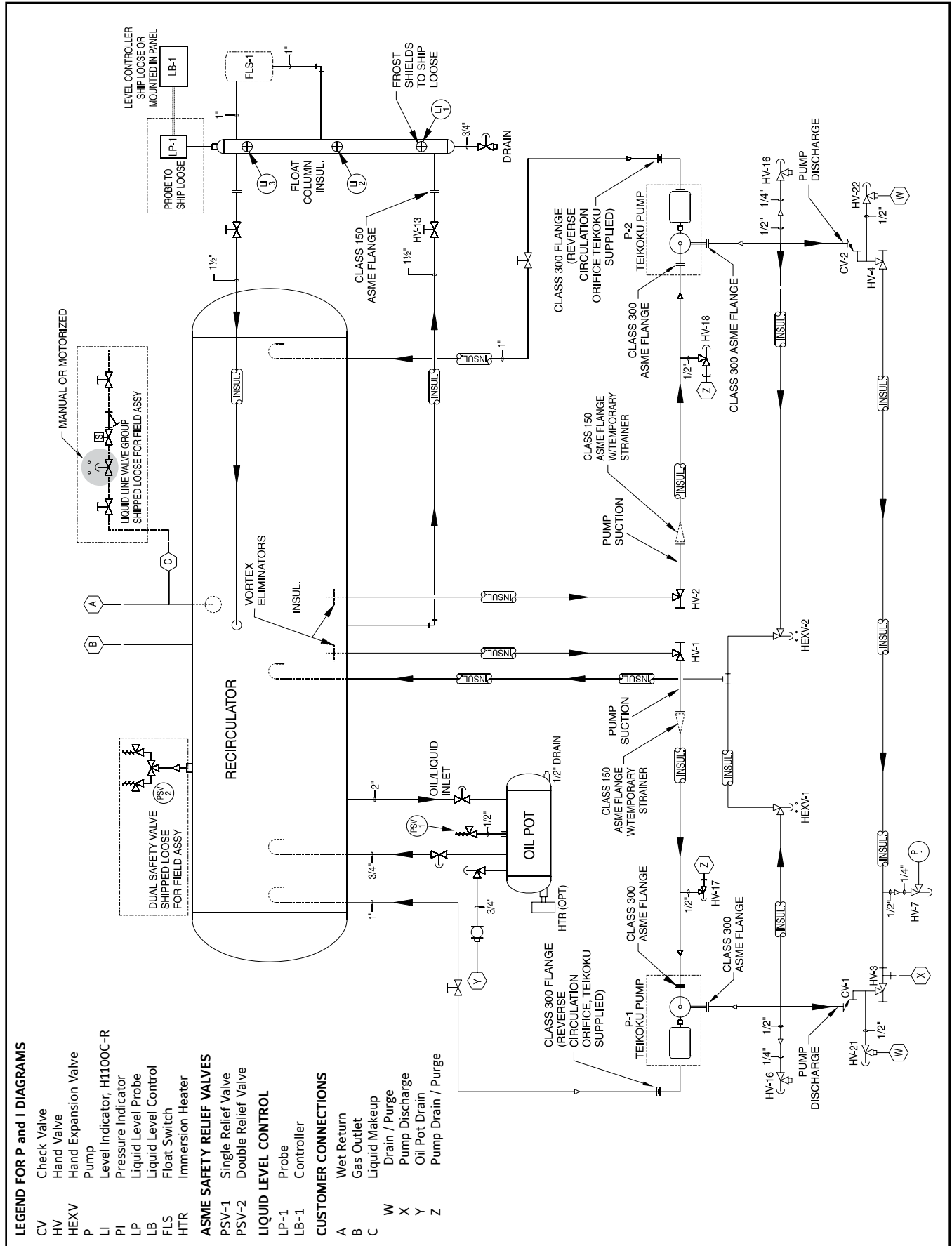

OIL RECOVERY SYSTEM FOR REFRIGERANTS OTHER THAN R-717

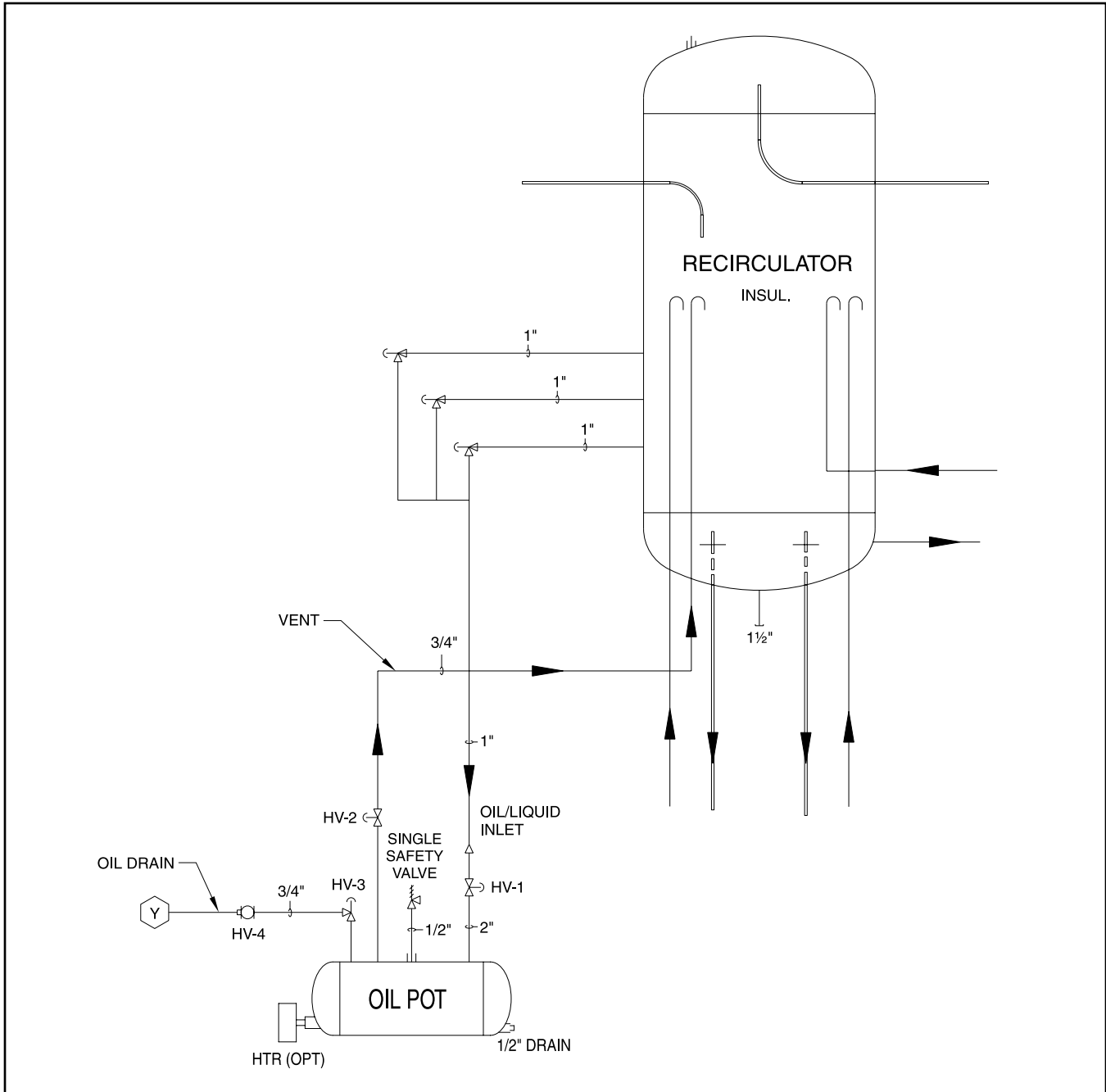

Oil Removal: Refer to “Oil Removal” in the Maintenance section of this manual.

RECIRCULATOR PANEL WITH DANFOSS LEVEL CONTROLLER

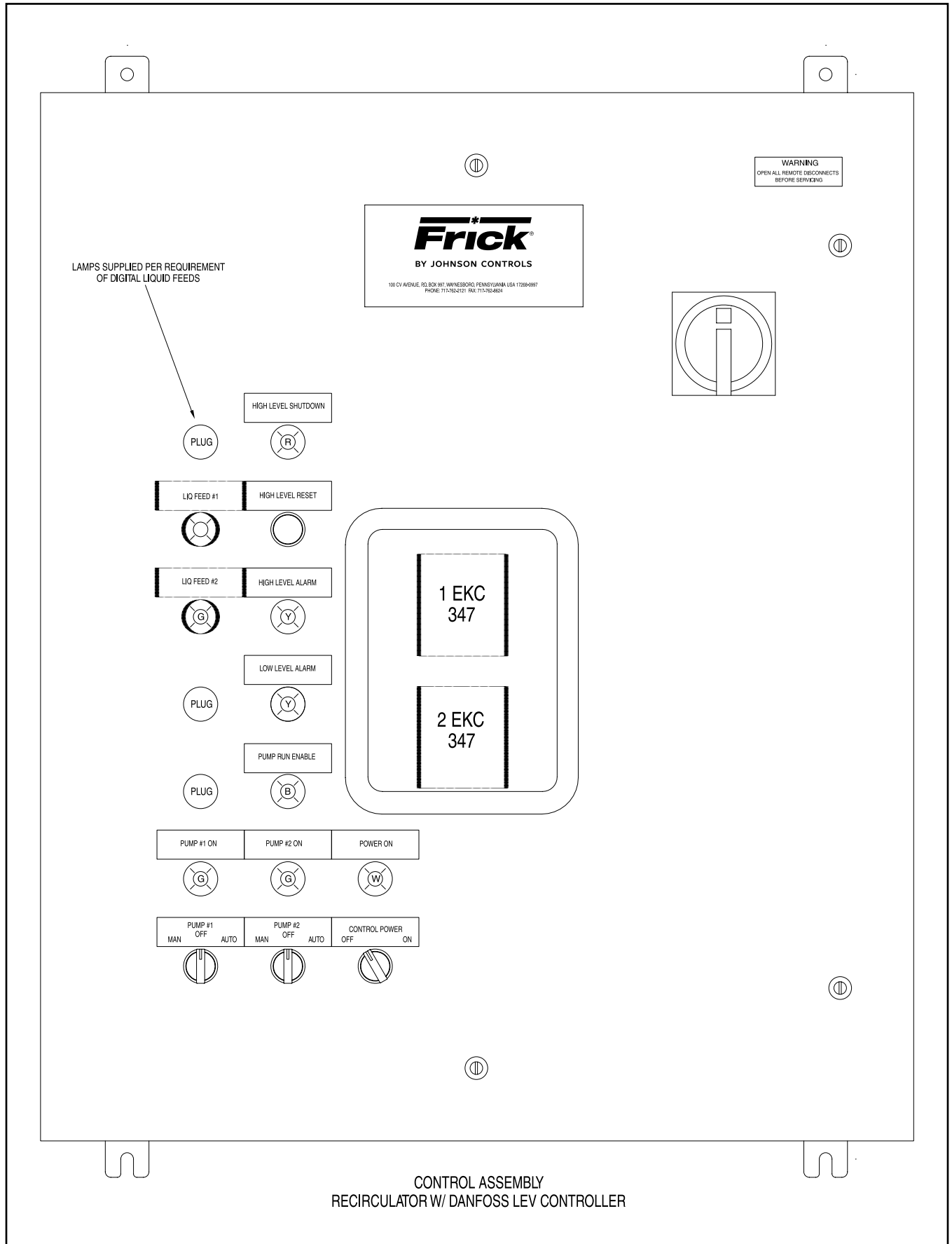

RECIRCULATOR PANEL WITH DANFOSS LEVEL CONTROLLER

SETPOINT INSTRUCTIONS

1 EKC-347 OPERATING LEVEL: DEPRESS BOTH BUTTONS TOGETHER, THE OPERATING LEVEL APPEARS AND IS FLASHING USE TOP AND BOTTOM TO SET, DEPRESS BOTH BUTTONS AGAIN AND THE DISPLAY WILL RETURN TO OPERATING LIQ LEVEL, FACTORY SET @ 50%

FOR PARAMETER FUNCTIONS:

PRESS UPPER BUTTON AND HOLD UNTIL THE FIRST PARAMETER "r06" APPEARS.
MOMENTARILY PRESS THE LOWER BUTTON AND "r12" WILL APPEAR.
MOMENTARILY PRESS BOTH BUTTONS AT THE SAME TIME AND THE SETPOINT WILL APPEAR.
PUSH EITHER BUTTON IN THE DIRECTION YOU WANT TO GO UNTIL VALVE IS REACHED.
MOMENTARILY PRESS BOTH BUTTONS AGAIN AND THE VALUE IS SET. "r12" WILL REAPPEAR.
PRESS THE LOWER BUTTON TO STEP TO THE NEXT PARAMETER (A01) & REPEAT AS ABOVE.
APPROXIMATELY 20 SECONDS ARE ALLOWED FOR EACH BUTTON PRESS BEFORE THE DISPLAY RETURNS TO THE LIQUID LEVEL VALUE.

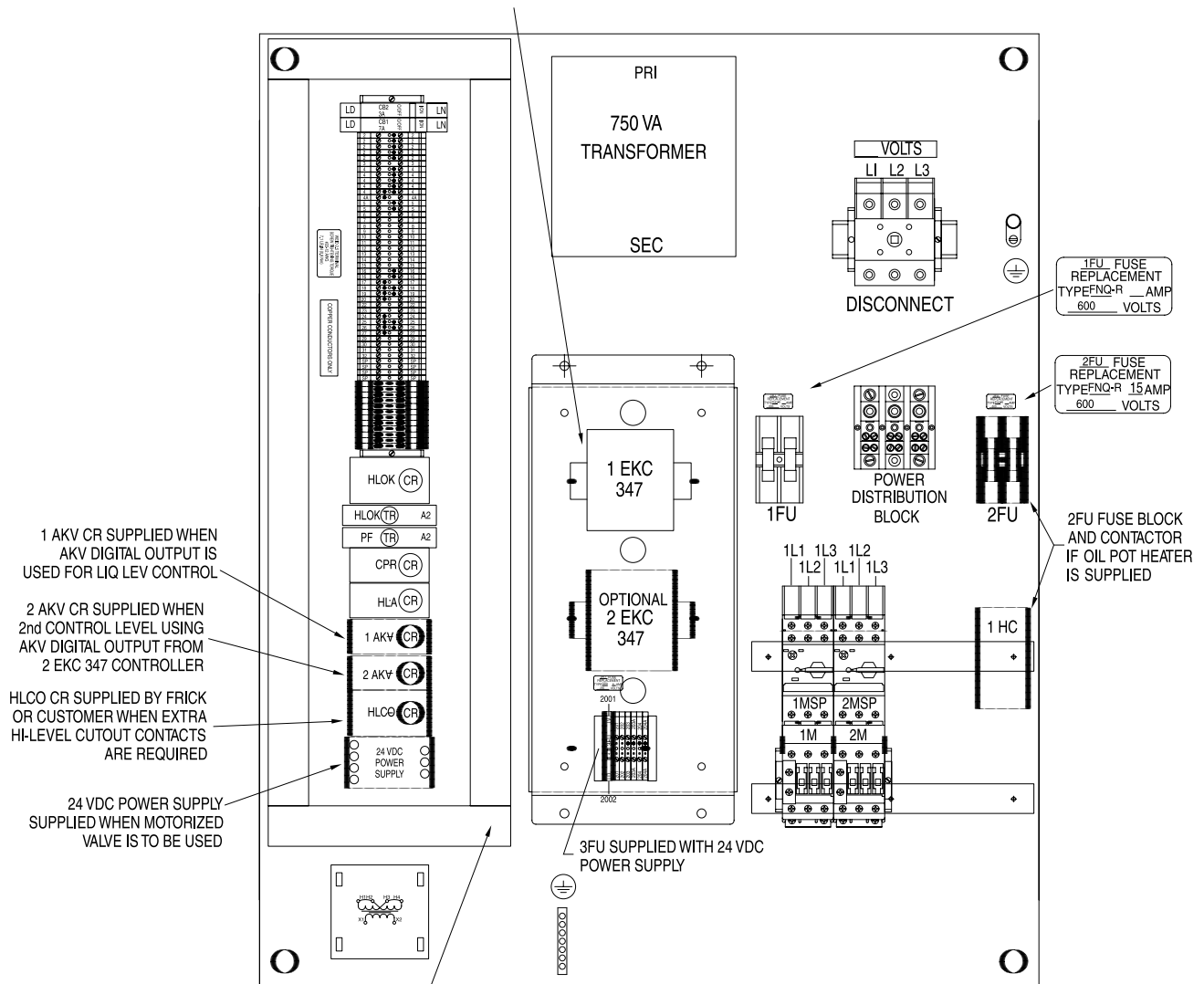

1 AKV CR SUPPLIED WHEN AKV DIGITAL OUTPUT IS USED FOR LIQ LEV CONTROL

2 AKV CR SUPPLIED WHEN 2nd CONTROL LEVEL USING AKV DIGITAL OUTPUT FROM 2 EKC 347 CONTROLLER

HLCG CR SUPPLIED BY FRICK OR CUSTOMER WHEN EXTRA HI-LEVEL CUTOUT CONTACTS ARE REQUIRED

24 VDC POWER SUPPLY SUPPLIED WHEN MOTORIZED VALVE IS TO BE USED

3FU SUPPLIED WITH 24 VDC POWER SUPPLY

1FU FUSE REPLACEMENT TYPE FNQ-R AMP 600 VOLTS

2FU FUSE REPLACEMENT TYPE FNQ-R 15 AMP 600 VOLTS

2FU FUSE BLOCK AND CONTACTOR IF OIL POT HEATER IS SUPPLIED

WIRING NOTE:
ALL FACTORY WIRING SHOULD ENTER THIS SIDE OF TERMINAL STRIP WHENEVER POSSIBLE TO MAKE AS MANY TERMINAL OPENINGS AVAILABLE AS POSSIBLE FOR CUSTOMER ON OTHER SIDE

NOTE: DIAL ON MSP 1STO BE SET TO MOTOR FLA ON NAMEPLATE.

**WIRING DIAGRAM OF RECIRCULATOR PACKAGE with DANFOSS LEVEL CONTROLLER
with SOLENOID LIQUID FEED ASSEMBLY for CORNELL and TEIKOKU PUMPS**

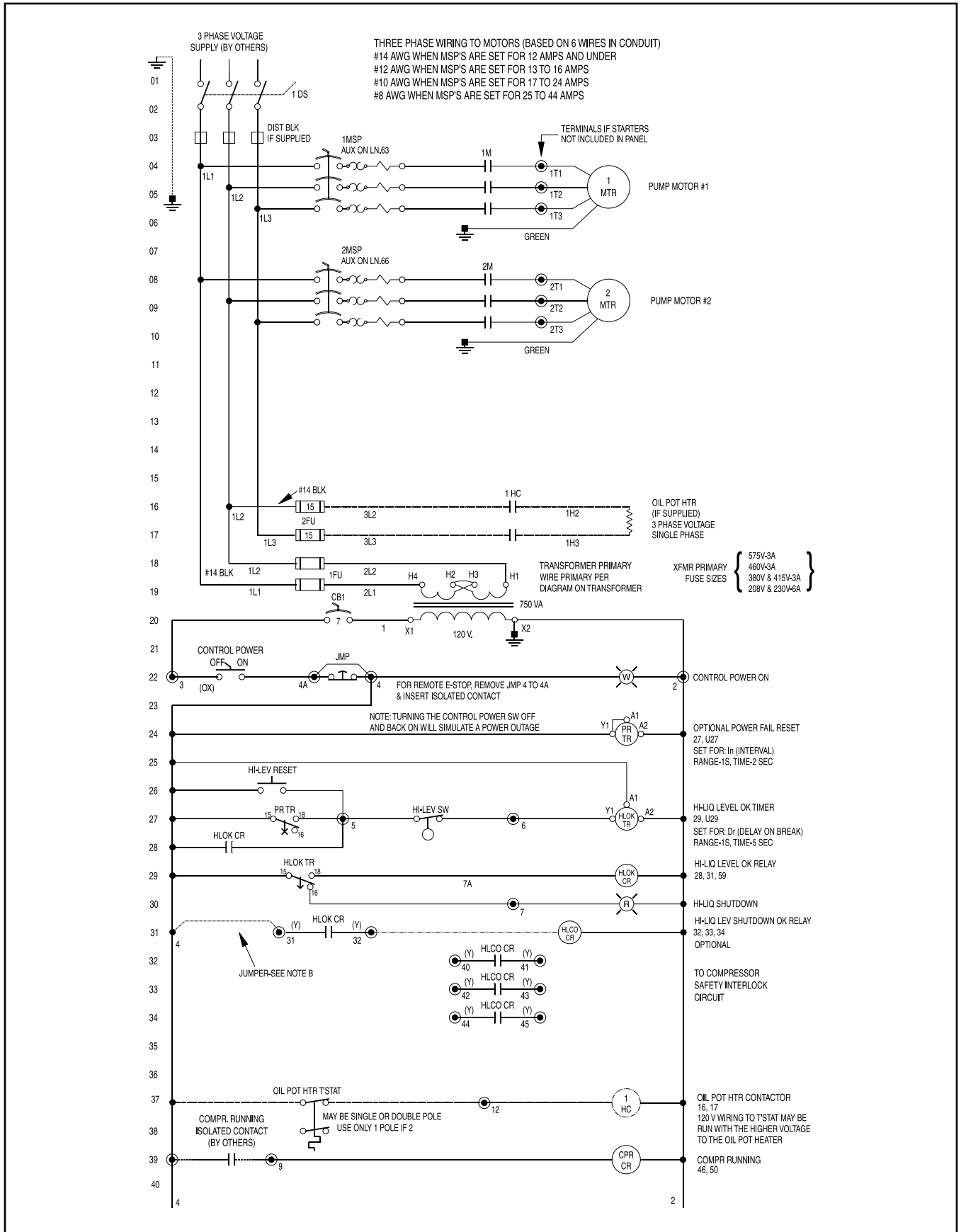

WIRING DIAGRAM OF RECIRCULATOR PACKAGE with DANFOSS LEVEL CONTROLLER with SOLENOID LIQUID FEED ASSEMBLY for CORNELL and TEIKOKU PUMPS

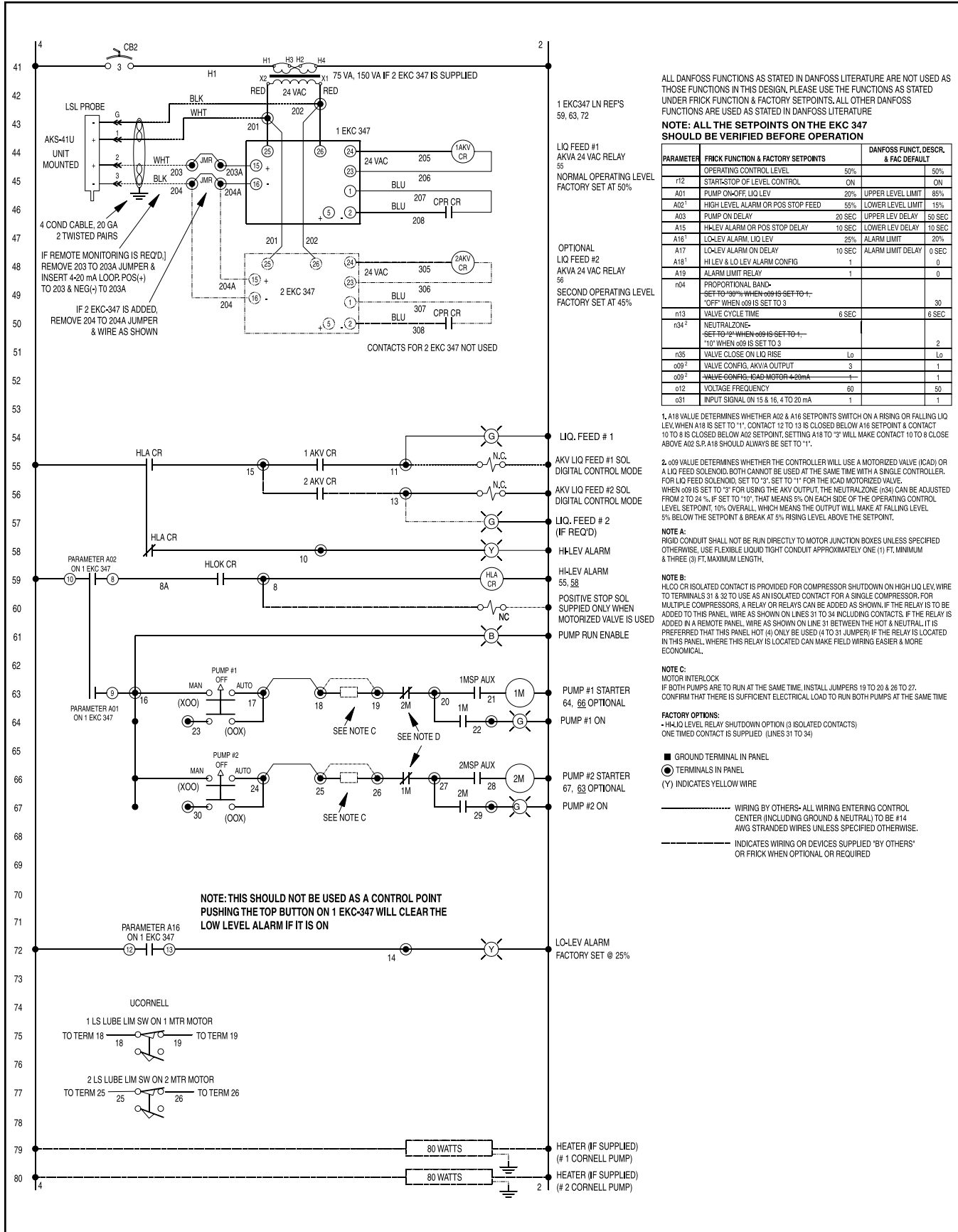

ALL DANFOSS FUNCTIONS AS STATED IN DANFOSS LITERATURE ARE NOT USED AS THOSE FUNCTIONS IN THIS DESIGN. PLEASE USE THE FUNCTIONS AS STATED UNDER FRICK FUNCTION & FACTORY SETPOINTS. ALL OTHER DANFOSS FUNCTIONS ARE USED AS STATED IN DANFOSS LITERATURE

NOTE: ALL THE SETPOINTS ON THE EKC 347 SHOULD BE VERIFIED BEFORE OPERATION

PARAMETER	FRICK FUNCTION & FACTORY SETPOINTS	DANFOSS FUNCT. DESCR. & FAC DEFAULT
r12	OPERATING CONTROL LEVEL 50%	50%
r12	START/STOP OF LEVEL CONTROL ON	ON
A01	PUMP ON-OFF LIQ LEV 20%	UPPER LEVEL LIMIT 85%
A02	HIGH LEVEL ALARM OR POS STOP FEED 55%	LOWER LEVEL LIMIT 15%
A03	PUMP ON DELAY 20 SEC	UPPER LEV DELAY 50 SEC
A15	HL-LEV ALARM OR POS STOP DELAY 10 SEC	LOWER LEV DELAY 10 SEC
A16	LO-LEV ALARM LIQ LEV 25%	ALARM LIMIT 20%
A17	LO-LEV ALARM ON DELAY 10 SEC	ALARM LIMIT DELAY 0 SEC
A18	HL-LEV & LO-LEV ALARM CONFIG 1	0
A19	ALARM LIMIT RELAY 1	0
r04	PROPORTIONAL BAND- SET TO 100% WHEN r09 IS SET TO +, 'OFF' WHEN r09 IS SET TO 3	30
r13	VALVE CYCLE TIME 6 SEC	8 SEC
r34	NEUTRALZONE- SET TO 10" WHEN r09 IS SET TO 1- '10' WHEN r09 IS SET TO 3	2
r35	VALVE CLOSE ON LIQ RISE Lo	Lo
r09	VALVE CONFIG. AKVA OUTPUT 3	1
r09	VALVE CONFIG. ICAD MOTOR 4-20mA 1-	1
r12	VOLTAGE FREQUENCY 60	50
r31	INPUT SIGNAL ON 15 & 16, 4 TO 20 mA 1	1

1. A18 VALUE DETERMINES WHETHER A02 & A16 SETPOINTS SWITCH ON A RISING OR FALLING LIQ LEV. WHEN A18 IS SET TO "1", CONTACT 12 TO 13 IS CLOSED BELOW A16 SETPOINT & CONTACT 10 TO 8 IS CLOSED BELOW A02 SETPOINT. SETTING A18 TO "3" WILL MAKE CONTACT 10 TO 8 CLOSE ABOVE A02 S.P. A16 SHOULD ALWAYS BE SET TO "1".

2. r09 VALUE DETERMINES WHETHER THE CONTROLLER WILL USE A MOTORIZED VALVE (ICAD) OR A LIQ FEED SOLENOID. BOTH CANNOT BE USED AT THE SAME TIME WITH A SINGLE CONTROLLER. FOR LIQ FEED SOLENOID, SET TO "3". SET TO "1" FOR THE ICAD MOTORIZED VALVE. WHEN r09 IS SET TO "3" FOR USING THE AKV OUTPUT, THE NEUTRALZONE (r34) CAN BE ADJUSTED FROM 2 TO 24 " IF SET TO "10". THAT MEANS 5% ON EACH SIDE OF THE OPERATING CONTROL LEVEL SETPOINT. 10% OVERALL, WHICH MEANS THE OUTPUT WILL MAKE AT FALLING LEVEL 5% BELOW THE SETPOINT & BREAK AT 5% RISING LEVEL ABOVE THE SETPOINT.

NOTE A: RIGID CONDUIT SHALL NOT BE RUN DIRECTLY TO MOTOR JUNCTION BOXES UNLESS SPECIFIED OTHERWISE. USE FLEXIBLE LIQUID TIGHT CONDUIT APPROXIMATELY ONE (1) FT. MINIMUM & THREE (3) FT. MAXIMUM LENGTH.

NOTE B: HLCO CR ISOLATED CONTACT IS PROVIDED FOR COMPRESSOR SHUTDOWN ON HIGH LIQ LEV. WIRE TO TERMINALS 31 & 32 TO USE AS AN ISOLATED CONTACT FOR A SINGLE COMPRESSOR. FOR MULTIPLE COMPRESSORS, A RELAY OR RELAYS CAN BE ADDED AS SHOWN. IF THE RELAY IS TO BE ADDED TO THIS PANEL, WIRE AS SHOWN ON LINES 31 TO 34 INCLUDING CONTACTS. IF THE RELAY IS ADDED IN A REMOTE PANEL, WIRE AS SHOWN ON LINE 31 BETWEEN THE HOT & NEUTRAL. IT IS PREFERRED THAT THIS PANEL HOT (4) ONLY BE USED (4 TO 31) JUMPER IF THE RELAY IS LOCATED IN THIS PANEL, WHERE THIS RELAY IS LOCATED CAN MAKE FIELD WIRING EASIER & MORE ECONOMICAL.

NOTE C: MOTOR INTERLOCK IF BOTH PUMPS ARE TO RUN AT THE SAME TIME, INSTALL JUMPERS 19 TO 20 & 26 TO 27. CONFIRM THAT THERE IS SUFFICIENT ELECTRICAL LOAD TO RUN BOTH PUMPS AT THE SAME TIME

FACTORY OPTIONS:
- H/LIQUID LEVEL RELAY SHUTDOWN OPTION (3 ISOLATED CONTACTS)
ONE TIMED CONTACT IS SUPPLIED (LINES 31 TO 34)

- GROUND TERMINAL IN PANEL
- TERMINALS IN PANEL
- (Y) INDICATES YELLOW WIRE
- WIRING BY OTHERS- ALL WIRING ENTERING CONTROL CENTER (INCLUDING GROUND & NEUTRAL) TO BE #14 AWG STRANDED WIRES UNLESS SPECIFIED OTHERWISE.
- INDICATES WIRING OR DEVICES SUPPLIED 'BY OTHERS' OR FRICK WHEN OPTIONAL OR REQUIRED

**WIRING DIAGRAM OF RECIRCULATOR PACKAGE with DANFOSS LEVEL CONTROLLER
with MOTORIZED LIQUID FEED ASSEMBLY for CORNELL and TEIKOKU PUMPS**

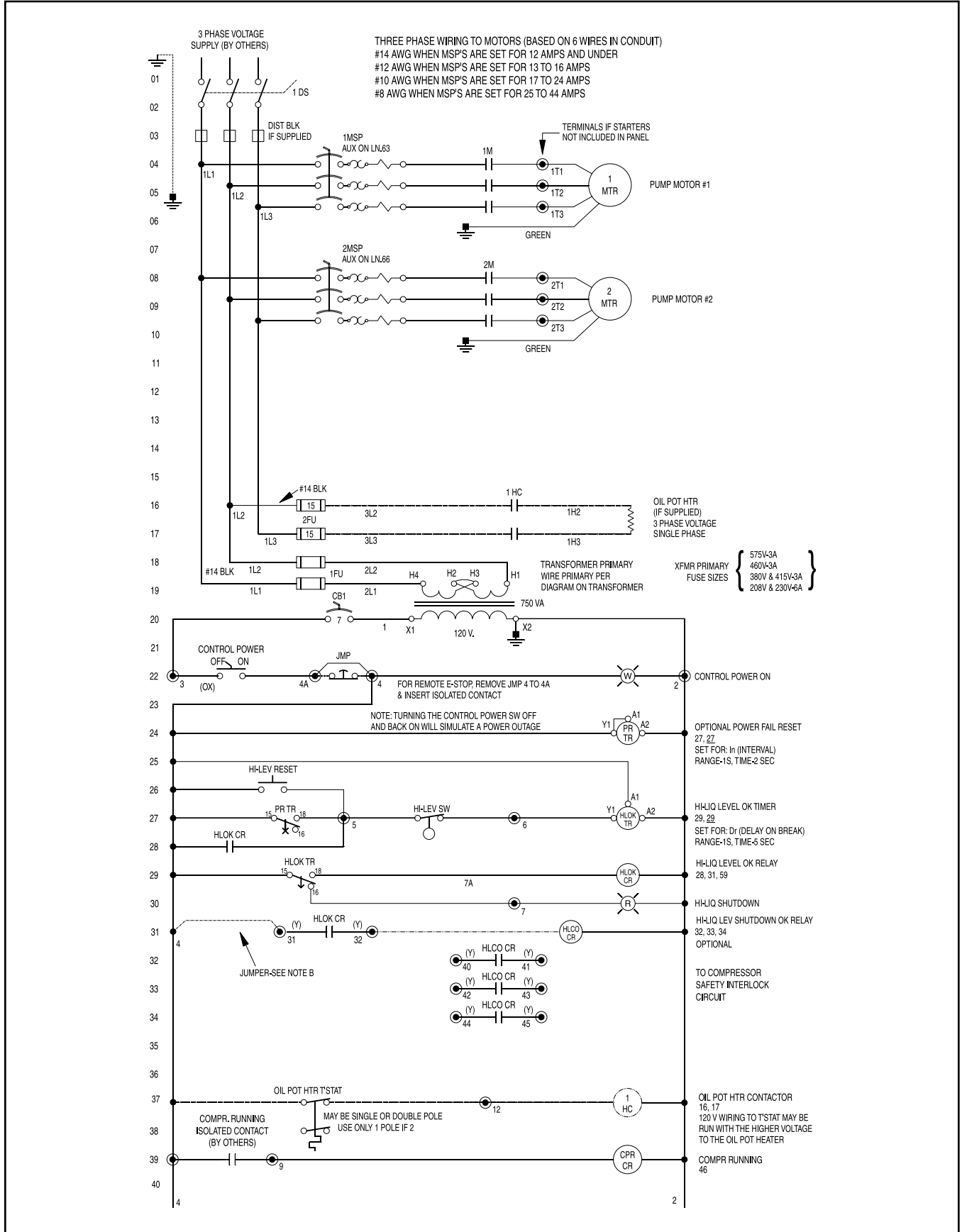

WIRING DIAGRAM OF RECIRCULATOR PACKAGE with DANFOSS LEVEL CONTROLLER with MOTORIZED LIQUID FEED ASSEMBLY for CORNELL and TEIKOKU PUMPS

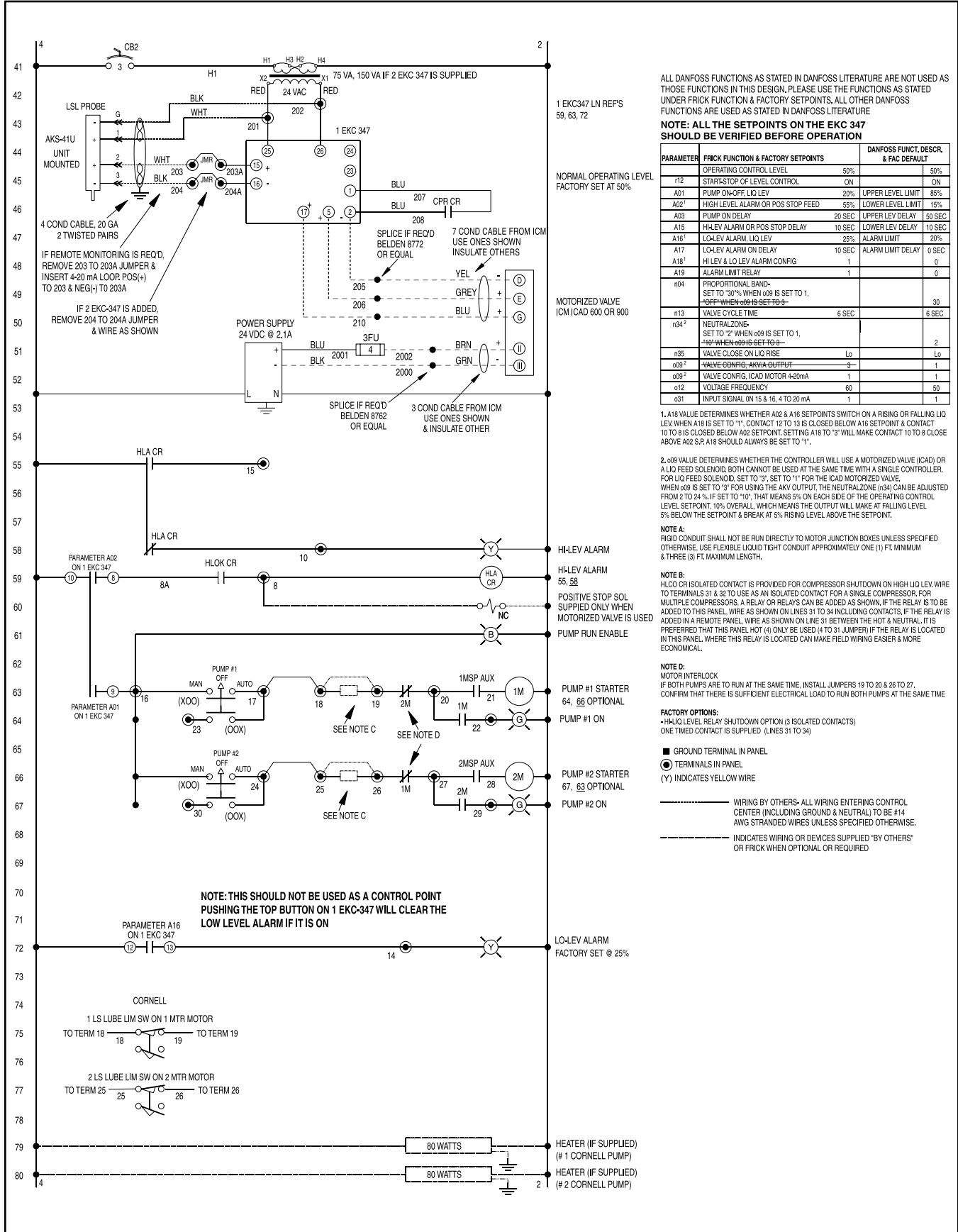

PROPER INSTALLATION OF ELECTRONIC EQUIPMENT IN AN INDUSTRIAL ENVIRONMENT

In today's refrigeration plants, electronic controls have found their way into almost every aspect of refrigeration control. Electronic controls have brought to the industry more precise control, improved energy savings, and operator conveniences. Electronic control devices have revolutionized the way refrigeration plants operate today.

The earlier relay systems were virtually immune to radio frequency interference (RFI), electromagnetic interference (EMI), and ground loop currents. Therefore installation and wiring were of little consequence and the wiring job consisted of hooking up the point-to-point wiring and sizing the wire properly. In an electronic system, improper installation will cause problems that may outweigh the benefits of electronic control. Electronic equipment is susceptible to RFI, EMI, and ground loop currents which can cause equipment shutdowns, processor memory and program loss, as well as erratic behavior and false readings. Manufacturers of industrial electronic equipment take into consideration the effects of RFI, EMI, and ground loop currents and incorporate protection of the electronics in their designs. However, these design considerations do not make the equipment immune, so manufacturers require that certain installation precautions be taken to protect the electronics from these effects. All electronic equipment must be viewed as sensitive instrumentation and therefore requires careful attention to installation procedures. These procedures are well known to instrumentation, networking, and other professions but may not be followed by general electricians.

There are a few basic practices that if followed, will minimize the potential for problems resulting from RFI, EMI and/or ground loop currents. The National Electric Code (NEC) is a guideline for safe wiring practices, but it does not necessarily deal with procedures used for electronic control installation. Use the following procedures for electronic equipment installation. These procedures do not override any rules by the NEC, but are to be used in conjunction with the NEC code and any other applicable codes.

With exclusion of the three phase wire sizing, Frick drawing 649D4743 should be used as a reference for properly sizing control wires and other wiring specifications.

Throughout this document the term Electronic Control Panel is used to refer to the microprocessor mounted on the compressor package or a Central Control System panel.

NOTE: It is very important to read the installation instructions thoroughly before beginning the project. Make sure you have drawings and instructions with your equipment. If not, call the manufacturer and request the proper instructions and drawings. Every manufacturer of electronic equipment should have a knowledgeable staff, willing to answer your questions or provide additional information. Following correct wiring procedures will ensure proper installation and consequently, proper operation of your electronic equipment.

WIRE SIZING

Control power supply wires should be sized one size larger than required for amperage draw to reduce instantaneous voltage dips caused by large loads such as heaters, contactors, and solenoids. These sudden dips in voltage can cause the electronic control panel, whether it is a microprocessor, a computer, or a PLC, to malfunction momentarily or cause a complete reset of the control system. If the wire is

loaded to its maximum capacity, the voltage dips are much larger, and the potential of a malfunction is very high. If the wire is sized one size larger than required, the voltage dips are smaller than in a fully loaded supply wire and the potential for malfunction is much lower. The NEC code book calls for specific wire sizes to be used based on current draw. An example of this would be to use #14 gauge wire for circuits up to 15 amps or #12 gauge wire for circuits of up to 20 amps. Therefore, when connecting the power feed circuit to an electronic control panel, use #12 gauge wire for a maximum current draw of 15 amp and #10 wire for a maximum current draw of 20 amp. Use this rule of thumb to minimize voltage dips at the electronic control panel.

VOLTAGE SOURCE

Selecting the voltage source is extremely important for proper operation of electronic equipment in an industrial environment. Standard procedure for electronic instrumentation is to provide a clean, isolated, separate-source voltage in order to prevent EMI (from other equipment in the plant) from interfering with the operation of the electronic equipment. Connecting electronic equipment to a breaker panel (also known as lighting panels or utility panels) subjects the electronic equipment to noise generated by other devices connected to the breaker panel. This noise is known as electromagnetic interference (EMI). EMI flows on the wires that are common to a circuit. EMI cannot travel easily through transformers and therefore can be isolated from selected circuits. Use a control power transformer of the proper VA rating, usually provided in the compressor drive motor starter, to isolate the electronic control panel from other equipment in the plant that generate EMI. See Figure 23.

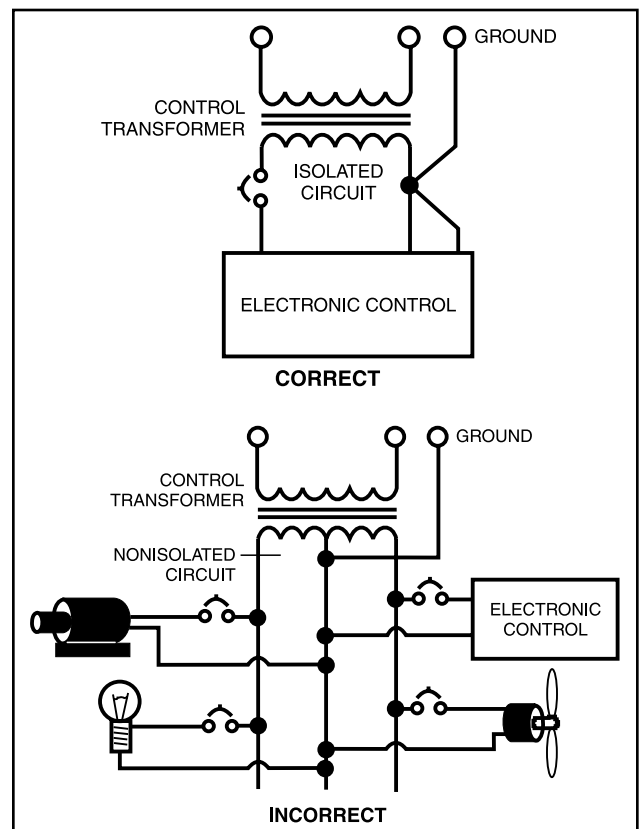

Figure 23

GROUNDING

Grounding is the most important factor for successful operation and is typically the most overlooked. The NEC states that control equipment may be grounded by using the rigid conduit as a conductor. This worked for the earlier relay systems, but it is in no way acceptable for electronic control equipment. Conduit is made of steel and is a poor conductor relative to an insulated stranded copper wire. Electronic equipment reacts to very small currents and must have a proper ground in order to operate properly; therefore, stranded copper grounds are required for proper operation.

For proper operation, the control power ground circuit must be a single continuous circuit of the proper sized insulated stranded conductor, from the electronic control panel to the plant supply transformer (Figure 24). Driving a ground stake at the electronic control may also cause additional problems since other equipment in the plant on the same circuits may ground themselves to the ground stake causing large ground flow at the electronic control panel. Also, running multiple ground conductors into the electronic control panel from various locations can create multiple potentials resulting in ground loop currents. A single ground wire (10 AWG or 8 AWG) from the electronic control panel, that is bonded to the control power neutral at the secondary side of the control power transformer in the starter and then to the 3-phase ground point, will yield the best results.

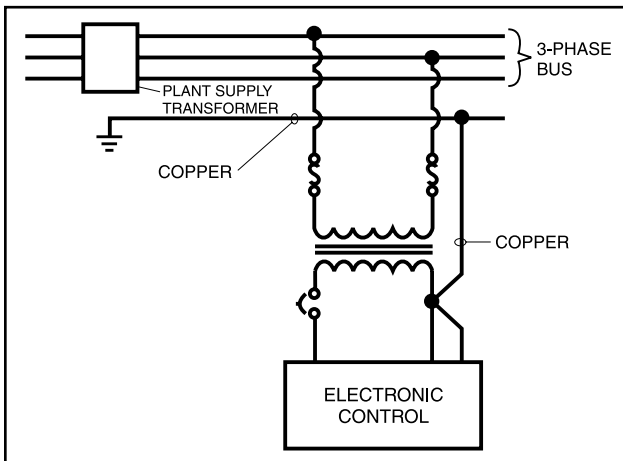

Figure 24

NOTE: Structural grounding can also result in multiple ground potentials and is also a relatively poor conductor. Therefore, this is not an acceptable method for proper operation of electronic equipment.

There must be a ground for the three-phase power wiring. This must be sized in accordance to the NEC and any local codes relative to the highest rated circuit overload protection provided in the circuit. The manufacturer may require a larger ground conductor than what is required by the NEC for proper steering of EMI from sensitive circuits. This conductor must also be insulated to avoid inadvertent contact at multiple points to ground, which could create Ground Loops. In many installations that are having electronic control problems, this essential wire is usually missing, is not insulated, or improperly sized.

NEC size ratings are for safety purposes and not necessarily for adequate relaying of noise (EMI) to earth ground to avoid possible interference with sensitive equipment. Therefore sizing this conductor 1 – 2 sizes larger than required by code will provide better transfer of this noise.

Frick requires that the ground conductor meet the following requirements be:

- Stranded Copper
- Insulated
- One size larger than NEC requirements for conventional starters
- Two sizes larger than NEC requirements for VFD starters
- Conduit must be grounded at each end
- This circuit must be complete from the motor to the starter continuing in a seamless manner back to the plant supply transformer (power source).

For Direct Coupled, Package Mounted Starters, the ground between the motor and the starter may need to be made externally (Figure 25). The connection on the starter end must be on the starter side of the vibration isolators. Be certain the connection is metal to metal. Paint may need to be removed to ensure a proper conductive circuit. The use of counter-sunk star washers at the point of connection at each end will maximize metal to metal contact.

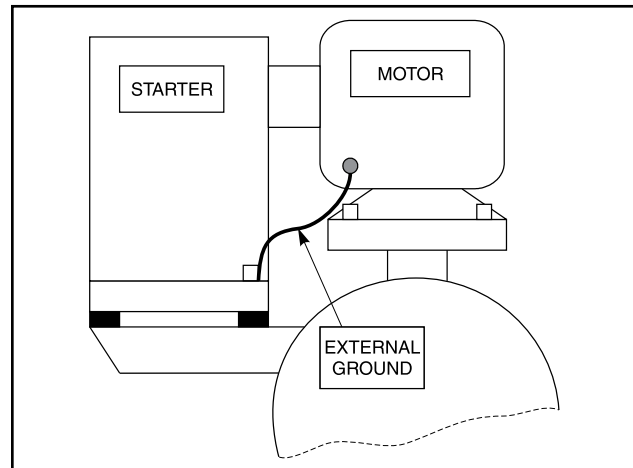

Figure 25

VFD APPLICATIONS

The primary ground conductor that accompanies the three-phase supply must be stranded copper, insulated and two sizes larger than the minimum required by the NEC or any other applicable codes. This is necessary due to the increased generation of EMI which is a characteristic of a VFD output to the motor when compared to a conventional starter.

For VFD applications, isolation of the control power, analog devices, and communications ground from the 3-phase ground within the starter and the electronic control panel may be necessary. This is due to the higher noise (RFI/EMI) levels generated between the VFD output and the motor, relative to a conventional starter. If these grounds are left coupled by a common back-plate in the starter/drive, this noise can be direct coupled to the control power, analog device, and

communications grounding and may cause unexplained behavior and possible damage to components.

To install correctly, run a separate, properly sized (10 or 8 AWG typically) insulated ground along with and taken to ground with, the 3-phase ground at the 3-phase supply transformer (plant). This will require that the 3-phase ground and the control power ground be electrically isolated except for the connection at the plant supply transformer.

This style of grounding should steer the noise (EMI/RFI) to earth ground, reducing the potential for it to affect the sensitive equipment, which could occur if the grounds were left coupled. **NOTE: If all other recommendations for grounding are followed, this process should not be necessary.**

CONDUIT

All national and local codes must be followed for conduit with regard to materials, spacing and grounding. In addition, **Johnson Controls-Frick requirements must be followed where they exceed or match national or local codes. Conversely, there is no allowance for any practices that are substandard to what is required by national or local codes.**

Johnson Controls-Frick conduit requirements:

- For *variable frequency drives* (VFDs) of any type, threaded metallic or threaded PVC-coated metallic is required for both the power feed (line side) from the source and between the VFD output and the motor (load side).
- PVC conduit is acceptable **only** when *VFD rated cable* of the proper conductor size and ground is used. This applies to both the line side and load side of the drive. When VFD rated cable is not used, threaded metallic or threaded PVC-coated metallic must be used.
- When threaded metallic or threaded PVC-coated metallic is used, it must be grounded at both ends.
- When not required to be in metal or other material by national or local codes, conduits for the power feed (3-phase) of constant speed starters may be PVC.
- When not required to be in metal or other material by national or local codes, conduits between a constant speed starter and the motor (3-phase) may be PVC.
- Any unshielded control voltage, signal, analog, or communication wiring that does not maintain 12 inches of separation from any 3-phase conductors for every 33 feet (10 meters) of parallel run must be in metal conduit which will be grounded.

Separation: (0-33 feet, 0-10 meters – 12 inches, .3 meters), (33-66 feet, 10-20 meters – 24 inches, .6 meters)

- Since PVC conduit does absolutely nothing to protect lower voltage lines from the magnetic field effects of higher voltage conductors, running either the lower or the higher voltage lines in PVC, does not reduce these requirements on separation. Only running in metal conduit can relieve these requirements.
- Due to the level of EMI that can be induced onto lower voltage lines when running multiple feeders in a trench, control power, communications, analog, or signal wiring cannot be run in trenches that house multiple conduits/electrical ducts carrying 3-phase power to starters/vfd or motors.

- Control power, communications, analog, or signal wiring should be run overhead (preferred) or in a separate trench. If these lines are not in threaded metallic or threaded PVC-coated metallic, abiding by the separation requirements noted above is necessary.
- Though not recommended, if cable trays are used, *metallic* dividers must be used for separation of conductors of unlike voltages and types (AC or DC).

NOTE: When in doubt contact the factory or use threaded metallic or threaded PVC coated metallic conduit.

WIRING PRACTICES

Do not mix wires of different voltages in the same conduit. An example of this would be the installation of a screw compressor package where the motor voltage is 480 volts and the electronic control panel power is 120 volts. The 480 volt circuit must be run from the motor starter to the motor in its own conduit. The 120 volt circuit must be run from the motor starter control transformer to the electronic control panel in its own separate conduit. If the two circuits are run in the same conduit, transients on the 480 volt circuit will be induced onto the 120 volt circuit causing functional problems with the electronic control panel. Metallic dividers must be used in wire way systems (conduit trays) to separate unlike voltages. The same rule applies for 120 volt wires and 220 volt wires. Also, never run low voltage wires for DC analog devices or serial communications in the same conduit with any AC wiring including 120 volt wires. See Figure 26.

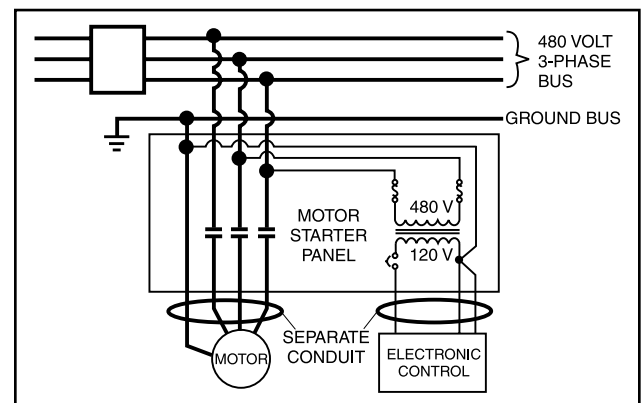

Figure 26

Never run any wires through an electronic control panel that do not relate to the function of the panel. Electronic control panels should never be used as a junction box. These wires may be carrying large transients that will interfere with the operation of the control panel. **An extreme example of this would be to run 480 volts from the starter through the electronic control panel to an oil pump motor.**

When running conduit to the electronic control panel, use the access holes (knockouts) provided by the manufacturer. These holes are strategically placed so that the field wiring does not interfere with the electronics in the panel. Never allow field wiring to come in close proximity with the controller boards since this will almost always cause problems.

Do not drill into an electronic control panel to locate conduit connections. You are probably not entering the panel where the manufacturer would like you to since most manufactur-

ers recommend or provide pre-punched conduit connections. You may also be negating the NEMA rating of the enclosure. Drilling can cause metal filings to land on the electronics and create a short circuit when power is applied. If you must drill the panel, take the following precautions:

- First, call the panel manufacturer before drilling into the panel to be sure you are entering the panel at the right place.
- Take measures to avoid ESD (electrostatic discharge) to the electronics as you prep the inside of the Electronic control panel. This can be done by employing an antistatic wrist band and mat connected to ground.
- Cover the electronics with plastic and secure it with masking or electrical tape.
- Place masking tape or duct tape on the inside of the panel where you are going to drill. The tape will catch most of the filings.
- Clean all of the remaining filings from the panel before removing the protective plastic.

When routing conduit to the top of an electronic control panel, condensation must be taken into consideration. Water can condense in the conduit and run into the panel causing catastrophic failure. Route the conduit to the sides or bottom of the panel and use a conduit drain. If the conduit must be routed to the top of the panel, use a sealable conduit fitting which is poured with a sealer after the wires have been pulled, terminated, and the control functions have been checked. A conduit entering the top of the enclosure must have a NEMA-4 hub type fitting between the conduit and the enclosure so that if water gets on top of the enclosure it cannot run in between the conduit and the enclosure. This is extremely important in outdoor applications.

NOTE: It is simply NEVER a good practice to enter through the top of an electronic control panel or starter panel that does not already have knockouts provided. If knockouts are not provided for this purpose it is obvious this is not recommended and could VOID WARRANTY.

Never add relays, starters, timers, transformers, etc. inside an electronic control panel without first contacting the manufacturer. Contact arcing and EMI emitted from these devices can interfere with the electronics. Relays and timers are routinely added to electronic control panels by the manufacturer, but the manufacturer knows the acceptable device types and proper placement in the panel that will keep interference to a minimum. If you need to add these devices, contact the manufacturer for the proper device types and placement.

Never run refrigerant tubing inside an electronic control panel. If the refrigerant is ammonia, a leak will totally destroy the electronics.

If the electronic control panel has a starter built into the same panel, be sure to run the higher voltage wires where indicated by the manufacturer. EMI from the wires can interfere with the electronics if run too close to the circuitry.

Never daisy-chain or parallel-connect power or ground wires to electronic control panels. Each electronic control panel must have its own control power supply and ground wires back to the power source (Plant Transformer). Multiple electronic control panels on the same power wires create current surges in the supply wires, which may cause controller malfunctions. Daisy-chaining ground wires, taking them to ground at each device, allows ground loop currents to flow between electronic control panels which also causes malfunctions. See Figure 27.

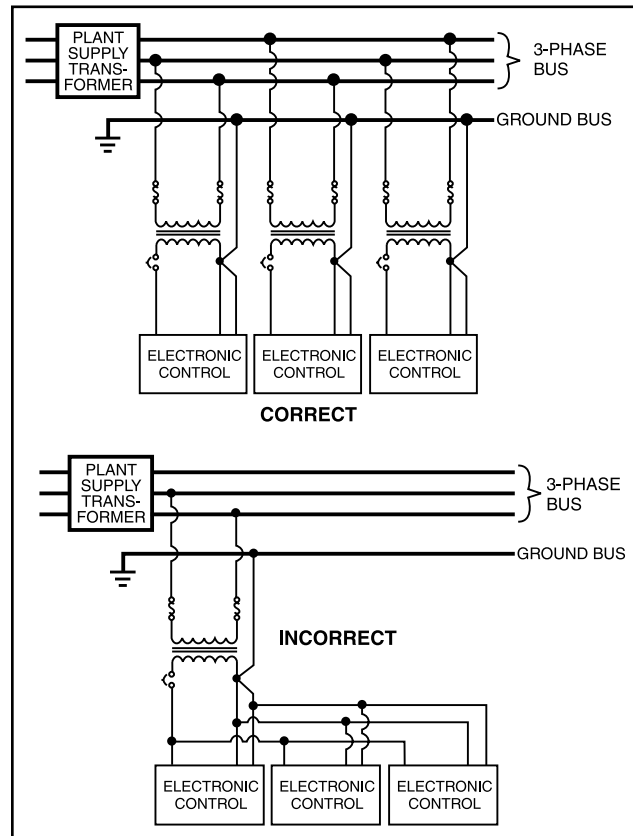

Figure 27

COMMUNICATIONS

The use of communications such as serial and ethernet in industrial environments are commonplace. The proper installation of these networks is as important to the proper operation of the communications as all of the preceding practices are to the equipment.

Serial communications cable needs to be of the proper gauge based on the total cable distance of the run. Daisy-chaining is the only acceptable style of running the communications cable. While Star Networks may use less cable, they more often than not cause problems and interruptions in communications, due to varying impedances over the varying lengths of cable. Ground or drain wires of the communications cable are to be tied together at each daisy-chain connection and only taken to ground in the central control system panel.

It is important to carefully consider the type of cable to be used. Just because a cable has the proper number of conductors and is shielded does not mean it is an acceptable cable. Frick recommends the use of Belden #9829 for RS-422 communications and Belden # 9841 for RS-485 up to 2000 feet (600 Meters) total cable length. Refer to Frick drawing 649D4743 for more detail

Comm Port Protection: Surge suppression for the comm ports may not be the best method, since suppression is required to divert excess voltage/current to ground. Therefore, the success of these devices is dependent on a good ground (covered earlier in this section). This excess energy can be quite high and without a proper ground, it will access the port and damage it.

Isolation or Optical Isolation is the preferred comm port protection method. With optical isolation, there is no continuity between the communications cable and the comm port. There is no dependence on the quality of the ground. Be sure to know what the voltage isolation value of the optical isolator is before selecting it. These may range from 500 to 4000 Volts.

Frick Optical Isolation Kits are offered under part number 639C0133G01. One kit is required per comm port.

UPS POWER AND QUANTUM™LX PANELS

Johnson Controls, Inc. does not advise nor support the use of uninterrupted power supply systems for use with the Quantum™LX panel. With a UPS system providing shutdown protection for a Quantum panel, the panel may not see the loss of the 3-phase voltage on the motor because the UPS may prevent the motor starter contactor from dropping out. With the starter contactor still energized, the compressor auxiliary will continue to feed an "okay" signal to the Quantum™LX panel. This may allow the motor to be subjected to the fault condition on the 3-phase bus.

A couple of fault scenarios are: 1. The 3-phase bus has power "on" and "off" in a continuous cycle manner which may cause the motor to overheat due to repeated excessive in-rush current experiences. 2. The motor cycling may damage the coupling or cause other mechanical damage due to the repeated high torque from rapid sequential motor "bumps." 3. Prolonged low voltage may cause the motor to stall and possibly overheat before the motor contactor is manually turned off.

Under normal conditions, the loss of 3-phase power will shut down the Quantum™LX panel and it will reboot upon proper power return. If the panel was in "Auto," it will come back and return to running as programmed. If the unit was in "Remote," the external controller will re-initialize the panel and proceed to run as required. If the panel was in "Manual" mode, the compressor will have to be restarted manually after the 3-phase bus fault/interruption has been cleared / restored.

If the local power distribution system is unstable or prone to problems there are other recommendations to satisfy these problems. If power spikes or low or high line voltages are the problem, then a constant voltage (CV) transformer with a noise suppression feature is recommended. Johnson Controls, Inc. can provide these types of transformers for this purpose. Contact Johnson Controls for proper sizing (VA Rating) based on the requirement of the job. If a phase loss occurs, then you will typically get a high motor amp shut-down. If the problem continues, an analysis of the facility's power supply quality may be necessary.

NOTE: It is very important to read the installation instructions thoroughly before beginning the project. Make sure you have drawings and instructions for the equipment being installed. If not, call the manufacturer to receive the proper instructions and drawings. Every manufacturer of electronic equipment should have a knowledgeable staff, willing to answer your questions or provide additional information. Following correct wiring procedures will ensure proper installation and consequently, proper operation of your electronic equipment.

Index

Symbols

3-phase ground 37
3-phase supply 37

A

Alarm relay 18
Ambient temperature 16
ammonia level 5
Ammonia Pump 4, 22, 23
ASME Safety Relief Valves 24, 25, 26, 27
atmospheric pressure 22

B

bearings 6
bypass line 6
bypass line valve 6

C

cable trays 37
calibration 17
calibration mode 18
Calibration mode 18
cavitate 23
cavitation 5, 6, 23
Change of refrigerant 18
check valve 24, 25, 26, 27
chemical goggles 5, 23
codes 37
coils 23
Comm Port Protection 39
Communications 39
compressor 23
Conduit 37
constant speed starters 37
controller 24, 26
controller 6, 25, 27
Cornell Pump 6
Current signal 18
customer connections 24, 25, 26, 27

D

Daisy-chaining 39
Data communication 18
defrost 6
defrost system 23
defrost time 23
design limitations 3
direction of rotation 6
discharge 6
discharge pressure 5, 6, 23

discharge stop valve 6
discharge valve 6
double relief valve 24, 25, 26, 27
drain valve 6
dry nitrogen 4

E

electrical control panel 4
emergency mode 5
Error Messages 21
evaporator 23
expansion valve 23
Expansion valve 18

F

face shield 5, 23
factory setting 18
field connections 4
float switch 23, 24, 25, 26, 27
foundation 4
frost 22, 23

G

gas mask 5, 23
gas outlet 24, 25, 26, 27
grinding 6

H

hand expansion valve 5, 6, 23, 24, 25, 26, 27
hand expansion valves 5
hand valve 24, 25, 26, 27
heater 6, 22, 23
holding charge and storage 4
hot gas solenoids 23
hydraulic pressure 15

I

ICAD 11
ICAD Actuator 9
alarms 11
Automatic calibration 11
Control input signal 9
digital output signals 11
hermetic magnetic motor coupling 11
Password protection 9
ICC requirement 3
ICE 22, 23
ICM motor valves 7
actuator 8
Butt weld 8
function modules 9

ICAD actuators 7
ICS servo valve 8
Magnet coupling 8
magnetic coupling 9
power failure 7
Socket weld 8
Solder connection 8
valve body 7
Valve inlet pressure 9
V-port regulating 8

ICM valve 18
Immersion Heater 24, 25, 26, 27
Initial Start-Up 6
input current 6
Installation 4
isolation valves 5

J

Job Inspection 3

L

leak test 4
level column 23
level controller 23
level indicator 24, 25, 26, 27
level transmitter 17, 18
liquid-feed solenoid 23
liquid bypass valve 23
liquid feed 23
liquid feed strainer 23
liquid injection
Alarms 12
analog input signal 12
Common Digital Alarm 12
Danfoss Liquid Injection Valve 11
High 12
ICAD (Industrial Control Actuator with Display) 11
ICM (Motorized Industrial Control Valve) 11
Low 12
Med 12
MMI (Man Machine Interface) 11
Mod 12
Opening Degree (OD) 12
Parameter list 13
Analog Input signal 13
Analog Output signal 13
Automatic calibration 13
igital Input function 13
Fail-safe 13
ICM configuration 13
Main Switch 13
Mode 13

Modulating Mode 13
Old Alarms 13
Password 13
parameters 11
digital Input signal 12
Display 12
Enter push button 11
ICAD (Industrial Control Actuator with Display) 11
ICM valve 12
MMI (Man Machine Interface) 11
Mod 12
Motorized Industrial Control Valve 11
Opening Degree 12
Parameter list 13
Analog Output signal 13
Automatic calibration 13
Digital Input function 13
Fail-safe 13
ICM configuration 13
Main Switch 13
Mode 13
Modulating Mode 13
Old Alarms 13
Password 13
parameters 11
solenoid valve 12
liquid level control 24, 25, 26, 27
liquid level controller 15
liquid level probe 24, 25, 26, 27
liquid makeup 24, 25, 26, 27
liquid solenoid 23
low-level alarm 23

M

magnetic field 37
MAINTENANCE 22
maximum refrigerant level 18
motor 6
motor recirculation line valves 6

N

nitrogen charge 4

O

oil/liquid inlet valve 22
oil drain isolation valve 22
oil pot 22, 23
oil pot drain 24, 25, 26, 27
Oil Recovery System 28
Oil Removal 22
oil reservoir 6
operating pump 5

Optical Isolation 39
OSHA 3
output signal 17

P

packing gland 14
P and I Diagrams 24, 26
parameter 12
Parameter list 13
pipe connections 4
piping loads 4
power feed 37
Preface 3
Pressure Equipment Directive 14
pressure indicator 24, 25, 26, 27
Pressure range 16
probe 24, 25, 26, 27
pump 6
Pump 24, 25, 26, 27
pump 5
pump bypass 5
pump bypass valve 23
pump discharge 24, 25, 26, 27
pump drain 24, 25, 26, 27
pump lubrication 5
pump suction spool piece 5
pump suction strainer 5
purge valves 23
P and I Diagrams 25, 27
PVC conduit 37

Q

Quantum™LX 39

R

reboot 39
recirculator 4, 5, 23
recirculator panel 29, 30
Recirculator Start-Up And Operation 5
refrigerant 17
Refrigerants 16
regulating valves 14
REG valves 15
Rigging and Handling 3
rotation 5

S

Safety Recommendations 23
scraping 6
Service 22
shipping gauges 4
signal damping 17

Signal damping 17
Signal output 16
Single Relief Valve 24, 25, 26, 27
Solenoid 23
solenoids 5
solenoid valve 12
spacer disc 5
spindle 14
spindle seal 14
spring-loaded seal 14
spring return valve 22
standby pump 6
Standby Pump 5
Star Networks 39
start-up procedures 5
stop valve 23
Suction 6
suction pressure 22
supply voltage 17
Supply voltage 16
Surge suppression 39

T

temperature conditions 4
Temperature range 16
threaded metallic 37
threaded PVC-coated metallic 37
Transit Damage Claims 3
Troubleshooting 23

U

uninterrupted power supply 39
Unit Identification 3
 identification data plate 3
unshielded 37
UPS 39

V

valve cone 14
variable frequency drives 37
vent valve 6, 22
VFD Applications 36
VFD output 36
vibration 6
VLT Hansen Probe 29, 30
voltage isolation 39
Voltage signal 18
volute 6

W

Wet Return 24, 25, 26, 27
Wiring Diagram 31, 32, 33, 34

Q-NET™ network technology...

Connect Your PC
with QUANTUM™LX!

*Take full advantage of Q-NET™
technology with all Frick products!*

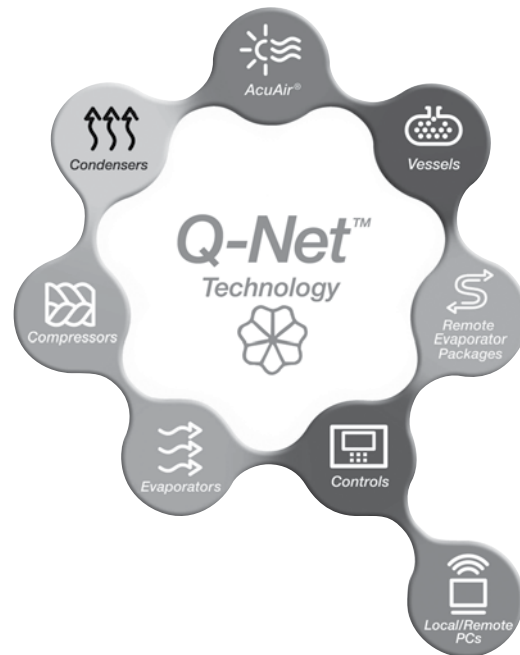

System integration is what we do...

- Q-NET™... supports open-protocols for SCADA systems (i.e. Allen-Bradley® DF1, Modbus RTU, Modbus ASCII, and Industrial Ethernet Protocols)
- Q-NET™... connects instantly for local or remote access; no software required
- Q-NET™... can be applied to both new and existing systems
- Q-NET™ means precise control 24 hours a day, seven days a week
- Q-NET™ distributed architecture mean faster, easier, economical installations
- Q-NET™ delivers increased operating efficiency and lowers energy costs

Available on Frick screw compressors, condensers, evaporators, AcuAir® hygienic air handlers, and refrigerant vessels.