



E120-720 SED/JAN 2004

File: EQUIPMENT MANUAL - Section 120
Replaces: Nothing, New Information
Dist: 1, 1a, 1b, 1c, 4, 4b, 4c

Specifications - Engineering Data - Dimensions

HORIZONTAL THERMOSYPHON RECEIVER

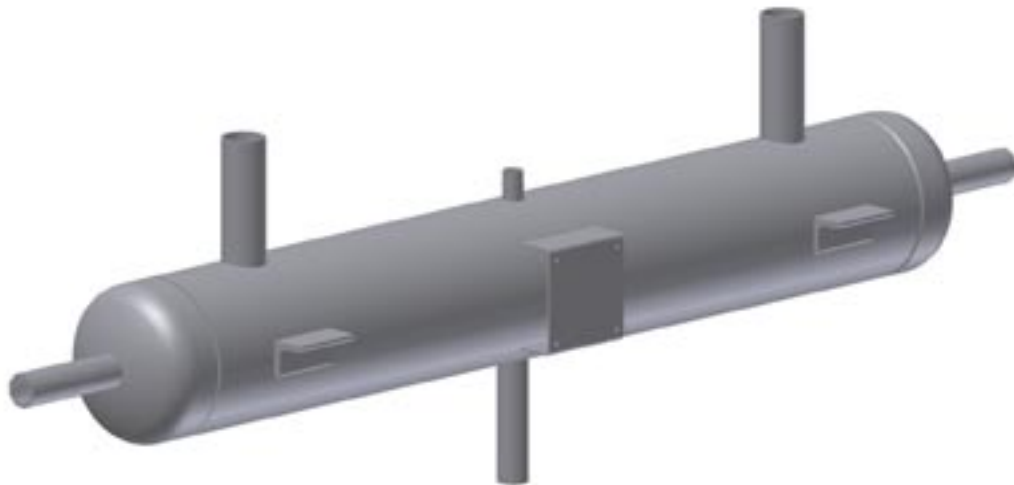

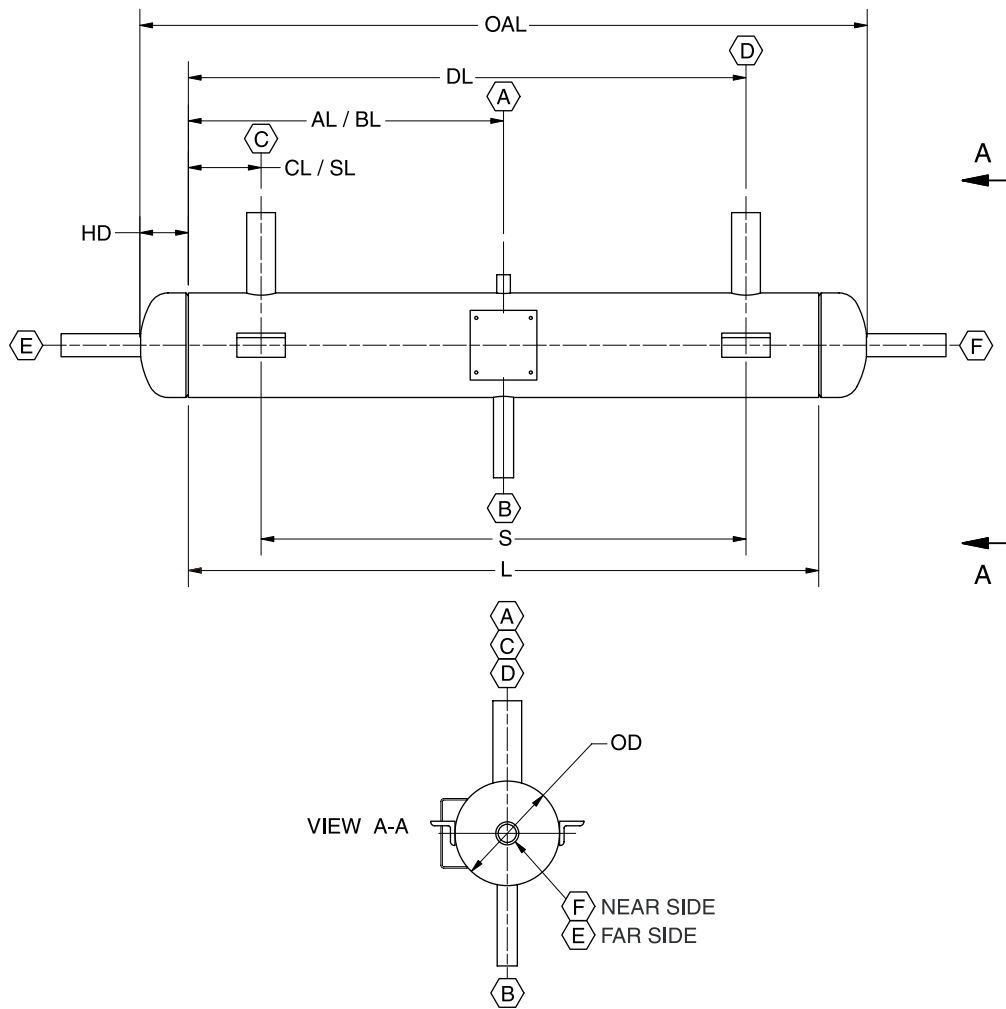

NOTES:

1. All dimensions and nozzle nominal pipe sizes are given in inches unless noted otherwise.
2. Operating charge based on ammonia @ +95°F filled to the centerline of the liquid in/out connections (E and F).
3. Nozzle connections are supplied as pipe stubs unless otherwise specified as a coupling (Cplg).
4. Couplings are ASME B16.11 Class 3000 "full" couplings.
5. **Nozzles are sized for R-717 and should not be used with other refrigerants (e.g. R-22 & R-507).**
6. Use minimum 2-inch standoff on nameplate bracket.
7. All dimensions are subject to change; please consult factory for certified drawings.
8. Vessels are built in accordance with ASME Boiler & Pressure Vessel Code, Section VIII, Division 1.

Key to Nozzle/Coupling Locations:

A	Relief (Coupling)	OD	Outside Diameter
B	TSOC Supply (Liquid)	L	Shell Length
C	TSOC Return (Gas)	OAL	Vessel Overall Length
D	Vent to Condenser	HD	Head Depth
E	Liquid from Condenser		
F	Liquid to Receiver		

Figure 1. Data and Dimensions

DIMENSIONAL DATA

MODEL NUMBER	MAWP	OD	OAL	HD	L	Uninsulated Dry Wt (lbm)	Total Volume (cu-ft)	R-717 (2) Operating Charge (lbm)
HTSR-8-60	300	8 ⁵ / ₈	60	4	52	180	1.7	30.8
HTSR-10-60	300	10 ³ / ₄	60	5	50	240	2.6	48.3
HTSR-12-60	300	12 ³ / ₄	60	6	48	290	3.7	68.8
HTSR-16-72	300	16	72 ¹ / ₄	6 ¹ / ₈	60	300	7.6	138.7
HTSR-20-72	300	20	72 ³ / ₈	7 ³ / ₁₆	58	560	11.5	211.6
HTSR-24-72	300	24	72 ³ / ₈	8 ³ / ₁₆	56	670	16.6	305.7
HTSR-30-84	250	30	84 ³ / ₈	9 ¹ / ₁₆	65	970	30.6	562.3

MODEL NUMBER	Nozzle/ Coupling NPS (see footnotes 3,4,5)						AL	BL	CL	DL	S	SL
	A	B	C	D	E	F						
HTSR-8-60	1/2	1 ¹ / ₄	2	2	1 ¹ / ₂	1 ¹ / ₂	26	26	6	46	40	6
HTSR-10-60	1/2	1 ¹ / ₂	2	2	2	2	25	25	6	44	38	6
HTSR-12-60	1/2	2	2 ¹ / ₂	2 ¹ / ₂	2 ¹ / ₂	2 ¹ / ₂	24	24	6	42	36	6
HTSR-16-72	1/2	2 ¹ / ₂	3	3	3	3	30	30	6	54	48	6
HTSR-20-72	1/2	3	4	4	4	4	29	29	6	52	46	6
HTSR-24-72	1/2	4	5	5	5	5	28	28	6	50	44	6
HTSR-30-84	3/4	6	8	6	8	8	32 ¹ / ₂	32 ¹ / ₂	8	59	51	8

Q-NET™ network technology...

Make the Connection with QUANTUM™!

Preengineered for Lower Cost
Distributed System with Remote Control
Single-Cable Network
Easy to Expand or Upgrade

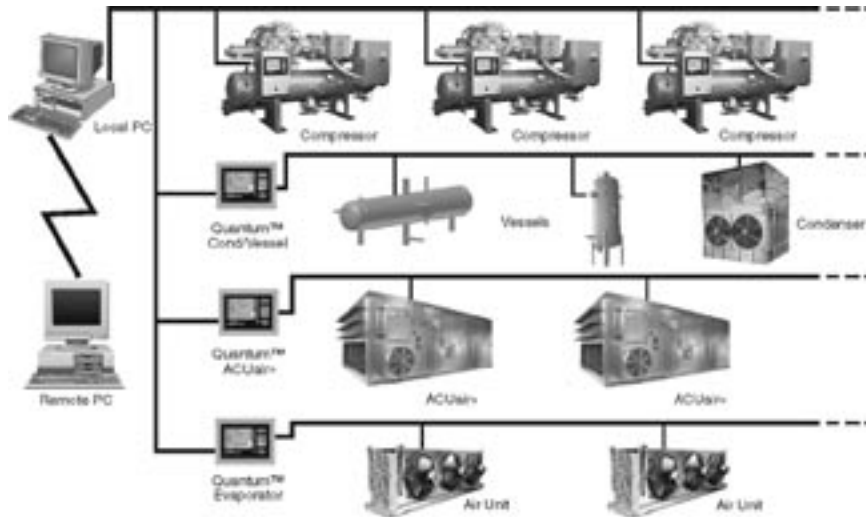

System integration is what we do...

- Q-NET™ ... supports open-protocols for SCADA systems (i.e. Allen Bradley DF1 and Modbus ASCII)
- Q-NET™ ... connects for local or remote access
- Q-NET™ ... can be applied to both new and existing systems

Q-NET™ means precise control 24 hours a day, seven days a week

Q-NET™ distributed architecture means faster, easier, economical installations

Q-NET™ delivers increased operating efficiency and lowers energy costs

Now available on Frick's ACUair® hygienic air handlers, condensers, screw compressors, evaporators, and refrigerant vessels, too.

Take full advantage of Q-NET™ technology with all Frick® products!



YORK Refrigeration Systems
100 CV Avenue • P.O. Box 997 • Waynesboro, Pennsylvania USA 17268-0997
Phone: 717-762-2121 • FAX: 717-762-8624 • www.frickcold.com