



Form 140.920 SED (NOV 2009)

SPECIFICATIONS - ENGINEERING DATA - DIMENSIONS

File: EQUIPMENT MANUAL - Section 140
Replaces: 140.920 SED (JUL 2009)
Dist: 1, 1a, 1b, 1c, 4, 4b, 4c

XLP2 Evaporative Condensers

A Reliable, Premium Quality Product
with Long-Term Low Cost of Ownership



Please check www.johnsoncontrols.com for the latest version of this publication.

Contents

Low Energy Consumption.....	3	Vibration Cutout Switch (Option).....	8
Low Installed Cost.....	3	Single-Point Wiring (Option).....	8
UniLink™ System.....	3	Electric Water Level Control Package (Option)	8
Easy Maintenance	3	Basin Heaters (Option).....	8
1 - Heavy Duty Construction.....	4	Basin Sweeper Piping (Option).....	8
2 - Water Distribution System	4	Solid Bottom Panels (Option).....	8
3 - Coil.....	4	Steel Eliminators (Option)	8
4 - Drift Eliminators	4	Table 1: Heater kW Data.....	9
5 - Independent Fan Drive System	4	Premium Efficient Motors.....	9
6 - Low Horsepower Axial Fan(s).....	4	Structural Support.....	9
7 - Recirculating Spray Pump.....	4	Beam Size and Length.....	9
8 - Access Door	4	Table 2: Beam Data	10
9 - Strainer (Not Shown)	4	Table 3: Heat Rejection Capacity Factors - R-717 ...	10
Long Service Life.....	4	Selection	10
Reliable Year Round Operation	4	Heat Rejection Method	10
Construction Details.....	5	Selection Procedure	10
Custom Features and Options	6	Table 4: Base Heat Rejection	11
Construction Options	6	Selection Example	12
Optional TripleGuard™ Corrosion Protection System:	6	Solution:.....	12
Optional DuraTest™ Construction:	6	Table 5: Heat Rejection Capacity Factors - R-134a..	12
Thermosetting Hybrid Polymer:.....	6	Evaporator Ton Method	12
Optional Water-Contact Stainless Steel Cold Water Basin: 6		Selection Procedure	12
Optional Water-Contact Stainless Steel Construction:.....	6	Selection Example: Screw Compressor	12
Optional All Stainless Steel Construction:	6	Table 6: Base Corrected Evaporator Tons	13
Coil Configurations.....	6	Table 7: Evaporator Capacity Factors - R-717	14
Standard Serpentine Coil:.....	6	Table 8: Evaporator Capacity Factors - R-134a	14
Optional Extended Surface Coil:.....	6	Table 9: Suction Temperature Factors - R-717	14
Optional Stainless Steel Coil:.....	6	Table 10: Suction Temperature Factors - R-134a	14
Optional ASME "U" Stamp Coil:	6	Engineering Data/Dimensions.....	15
Independent Drive System	7	Engineering Specifications	24
Extended Lubrication Lines	7	1.0 Evaporative Condenser.....	24
Multiple Refrigerant Circuit Coils (Option)	7	2.0 Construction Details	24
Auxiliary Water or Glycol Circuit (Option).....	7	3.0 Mechanical Equipment.....	25
Copper Sweat Fittings (Option).....	7	4.0 Sound.....	25
Accessories	8	5.0 Accessories	25
Pre-Assembled Platforms, Ladders, & Safety Cages (Option).....	8		

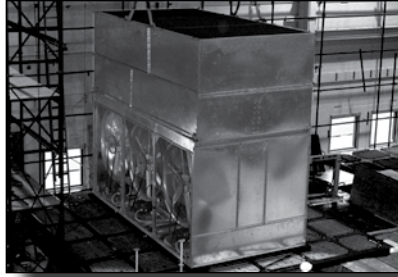

- **Full Size, Hinged Access Doors**
- **Pre-Assembled Platforms, Ladders & Safety Cages**
- **Premium Efficient Inverter Duty Motors**
- **IBC Compliant**
- **Independent Drive System**
- **TripleGuard™ Corrosion Protection System Option**
- **UniLink™ System**

Low Energy Consumption

Evaporative condensers minimize the energy consumption of the entire system by providing lower condensing temperatures. Owners save money while conserving natural resources and reducing environmental impact.

XLP2 Evaporative Condensers provide the heat rejection required at the lowest possible energy via:

- High efficient, low horsepower axial fans
- Premium efficient/VFD duty motors (standard)
- Variable Frequency Drives (Optional)
- Multiple fan models allow for capacity staging

Low Installed Cost

UniLink™ System – The coil section self aligns with the basin section. This feature significantly reduces the time required to rig the XLP2. Newly designed rigging ears allow for use of a single spreader bar per lift.



UniLink™ System

Support – All models mount directly on two parallel I-beams and ship complete with motors and drives factory-installed and aligned.

Modular Design – Large models ship in multiple sections to minimize the size and weight of the heaviest lift, allowing for the use of smaller, less costly cranes.

Single-Point Wiring (Optional) – Single-point wiring decreases installation time by routing wires, from motors (fan and pump) and options such as Vibration Cutout Switch (VCOS), Electric Water Level Control (EWLC) and basin heaters, in UL-listed conduit to a stainless steel NEMA 3R electrical box.

Easy Maintenance

Access Doors – Two 30" x 42" access doors are standard on side blow units and one on end blow units. This allows the interior of the unit to be easily accessed for adjusting the float valve, cleaning the strainer or flushing the basin. A large hinged internal partition door and an external door step are standard on all side blow units.

Harmony™ Removal System – Water distribution branch removal system that requires no tools.



Full Size Access Door(s) as Standard

Hygienic Cold Water Basin – The cold water basin is sloped to eliminate stagnant water and reduce biological growth. Additionally, the suction strainer is easily removed to simplify maintenance.

Fan Motors – The fan motors for the XLP2 are mounted in a horizontal position on an adjustable base. To aid belt tensioning and changing, the base is easily adjusted by turning one large nut.

Long Service Life

Materials of Construction – Various materials are available to meet the corrosion resistance and budgetary requirements of any project (see Construction Options section).

IBC Compliance – XLP2 Evaporative Condensers are designed to meet requirements of the 2006 International Building Code (IBC). Specifically, a unit was shake table tested at an independent lab in accordance with AC 156. Tests were conducted before and after testing to verify functionality and certify the use of XLP2 Evaporative Condensers in applications where the Component Importance Factor is 1.5. The standard unit can be verified up to an SDS of 1.4g which covers most US seismic applications. In addition, XLP2 Evaporative Condensers have been designed to withstand wind loads of 30 psf or higher.

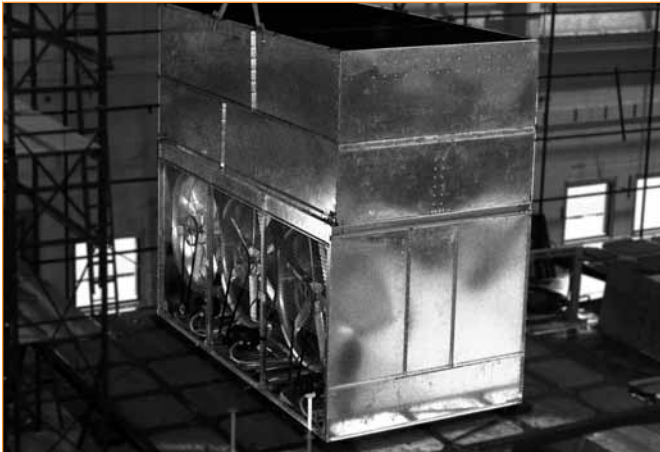

IBC Compliant XLP2 Evaporative Condenser

Reliable Year Round Operation

Powerband Belts – The fans, motor, and drive system are located outside of the moist discharge airstream, protecting them from moisture, condensation and icing. Backed by a 5-year fan drive and motor warranty, these units are suitable for year round operation.

Bearings – Minimum L_{10} bearing life of 94,000 hours delivers years of trouble-free service.

Nozzles – The nozzle design ensures the coil is completely wetted thereby delivering optimum heat transfer.

1 - Heavy Duty Construction

- G-235 (Z700 metric) hot-dip galvanized steel panels

2 - Water Distribution System

- Schedule 40 PVC spray branches
- Large orifice, 360° nonclog nozzles
- Nozzles and spray branches grommetted for easy maintenance

3 - Coil

- Continuous serpentine, steel tubing
- Hot-dip galvanized after fabrication (HDGAF)
- Pneumatically tested at 375 psig
- Sloped tubes for free drainage of fluid
- ASME B31.5 compliant
- Orders shipping into Canada are supplied with a CRN

4 - Drift Eliminators

- Polyvinyl chloride (PVC)
- Impervious to rot, decay, and biological attack
- Flame spread rating of 5 per ASTM E84
- Assembled in easy to handle sections

5 - Independent Fan Drive System

- Premium quality, solid-backed, multigroove belt
- Heavy-duty bearings L_{10} 94,000 hours
- Extended lubrication lines
- Premium efficient/VFD Duty fan motors are standard
- 5-year motor and drive warranty

6 - Low Horsepower Axial Fan(s)

- Corrosion resistant

7 - Recirculating Spray Pump

- Close coupled, bronze, fitted centrifugal pump
- Totally enclosed fan cooled (TEFC) motor
- Bleed line with metering valve installed from pump discharge to overflow

8 - Access Door

- Interior of unit is easily accessible
- Two 30" x 42" access doors are standard on side blow units
- One 30" x 42" access door is standard on end blow units

9 - Strainer (Not Shown)

- Antivortexing design to prevent air entrainment

Construction Details

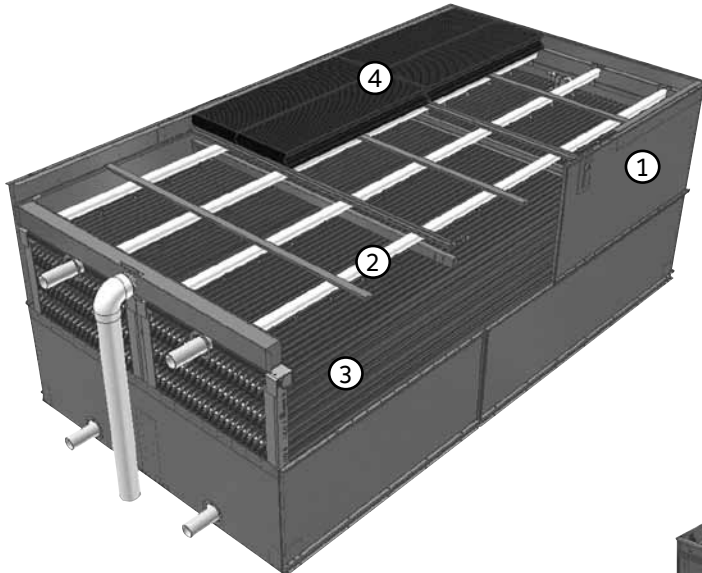

Upper Section

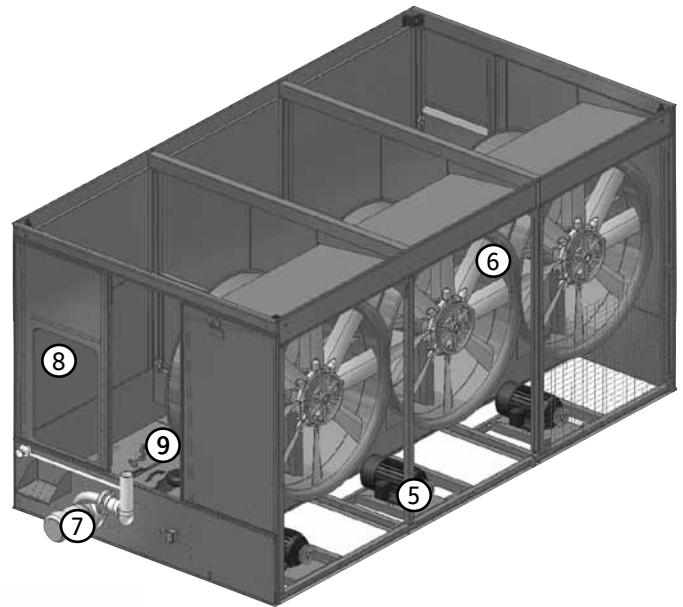

**Lower Section:
XLP2 Side Discharge Models**

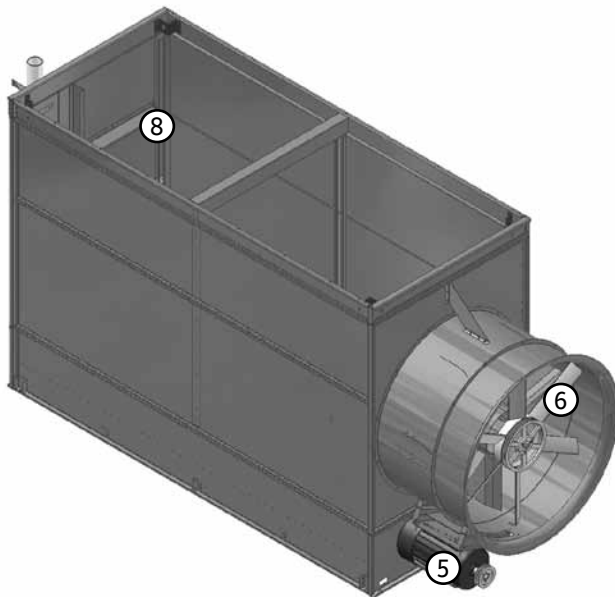

XLP2 End Discharge Models

Custom Features and Options

Construction Options

Standard Construction:

Steel panels and structural elements are constructed of G-235 (Z700 metric) hot-dip galvanized steel.

Optional TripleGuard™ Corrosion Protection System:

The cold water basin is constructed of the TripleGuard™ Corrosion Protection System. The system consists of a heavy-gauge G-235 galvanized steel substrate, fully encapsulated by a thermosetting hybrid polymer and further protected by a polyurethane barrier applied to all submerged surfaces of the cold water basin. The basin is leak tested at the factory and warranted against leaks and corrosion for 5 years.

Optional DuraTest™ Construction:

DuraTest™ Construction combines the most corrosion resistant materials to provide the best value in corrosion protection for most water chemistries. Specifically, the following materials are used:

- The cold water basin is constructed with the TripleGuard™ Corrosion Protection System. The basin is leak tested at the factory and warranted against leaks and corrosion for 5 years.
- Designated steel components above the cold water basin are constructed of heavy-gauge G-235 galvanized steel and further protected with a thermosetting hybrid polymer.

Thermosetting Hybrid Polymer:

A thermosetting hybrid polymer coating used to extend equipment life, is applied to select hot-dip galvanized steel components of the condenser. The thermosetting hybrid polymer has been tested to withstand 6000 hours in a 5% salt spray without blistering, chipping, or loss of adhesion.

Optional Water-Contact Stainless Steel Cold Water Basin:

A cost effective alternative to an all stainless steel cold water basin, all critical components in the cold water basin are provided in Type 304 stainless steel. The remaining components are constructed of the base material of construction (galvanized steel or a thermosetting hybrid polymer). Seams between the panels inside the cold water basin are welded. The basin is leak tested at the factory and welded seams are provided with a 5-year leak-proof warranty.

Optional Water-Contact Stainless Steel Construction:

A cost effective alternative to all stainless steel construction, all components that are exposed to the recirculating water are provided in Type 304 stainless steel. The remaining components are constructed of the base material of construction (galvanized steel, or a thermosetting hybrid polymer).

Optional All Stainless Steel Construction:

Steel panels and structural elements are constructed of Type 304 stainless steel.

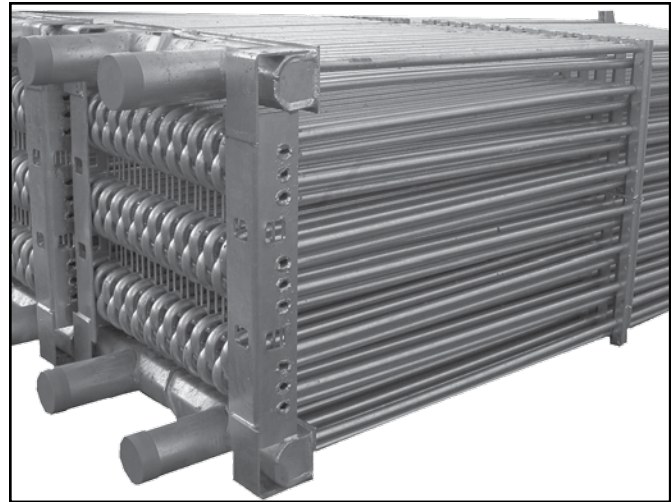

Serpentine Coil

Coil Configurations

Standard Serpentine Coil:

The standard refrigerant coil is constructed of continuous lengths of all prime surface steel, hot-dip galvanized after fabrication (HDGAF). The galvanizing is on the outside surface of the coil. The coil is designed for low pressure drop with sloping tubes for free drainage of fluid. Each coil is pneumatically tested at 375 psig (2,586 kPa) and is ASME B31.5 compliant.

Optional Extended Surface Coil:

Coils are available with finning at 5 fins per inch for seasonal wet/dry operation. The coil is hot-dip galvanized after fabrication (HDGAF). The galvanizing is on the outside surface of the coil. The coil is designed for low pressure drop with sloping tubes for free drainage of fluid. Each coil is pneumatically tested at 375 psig (2,586 kPa) and is ASME B31.5 compliant.

Optional Stainless Steel Coil:

Coils are available in Type 304 stainless steel for specialized applications. The coil is designed for low pressure drop with sloping tubes for free drainage of fluid. Each coil is pneumatically tested at 375 psig (2,586 kPa) and is ASME B31.5 compliant.

Optional ASME "U" Stamp Coil:

This coil is manufactured and tested in accordance with the ASME Boiler and Pressure Vessel Code, Section VIII, Division 1, and bears the ASME "U" stamp. ASME coils are hot-dip galvanized (outside surface) after fabrication (HDGAF). The coil is designed for low pressure drop with sloping tubes for free drainage of fluid. Each coil is pneumatically tested at 335 psig (2,310 kPa).

When required, orders shipping into Canada are supplied with a CRN. Other coil configurations are available for specific applications. Contact your local Frick Representative for details.

Independent Drive System

The fans, motors, and drive system of the XLP2 are located outside of the moist discharge air stream, protecting them from moisture and icing, while facilitating maintenance.

- Fans are supplied with dedicated motors
- Minimum L₁₀ bearing life is 94,000 hours
- Premium efficient/inverter duty motors are standard
- Motors meet NEMA Standard MG 31, Section IV, Part 31
- Dual drive option is available for retrofit applications to avoid costly rewiring

Extended Lubrication Lines

Extended lubrication lines with grease fittings located outside the fan section for lubrication of the fan shaft bearings are standard on XLP2 Evaporative Condensers.

Multiple Refrigerant Circuit Coils (Option)

Multiple circuit coils are generally required on halocarbon refrigerant systems, where it is common practice to maintain individual compressor systems. The quantity of circuits, capacity per circuit, and desired connection size should be specified when requesting this option.

Auxiliary Water or Glycol Circuit (Option)

A circuit can be isolated to provide cooling of a water or glycol loop for compressor jacket cooling. The flow rate and entering temperature should be specified when requesting this option. The leaving temperature should be the same as the condensing temperature.

Copper Sweat Fittings (Option)

Optional copper sweat fittings are available to simplify field piping for halocarbon based systems.

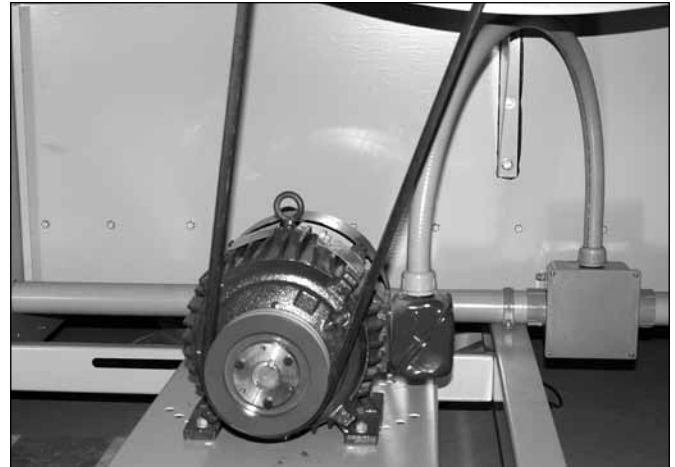

Independent Drive System



Extended Lubrication Lines

Accessories

Pre-Assembled Platforms, Ladders, & Safety Cages (Option)

Modular external platforms are pre-assembled at the factory to ensure that every component will fit and function exactly as described. The platform will attach quickly in the field with minimal fasteners. Platforms can be added at the time of order or as an aftermarket item. Safety gates are available for all handrail openings. All components are designed to meet OSHA requirements.

Vibration Cutout Switch (Option)

A factory-mounted vibration cutout switch is available to effectively protect against equipment failure due to excessive vibration of the mechanical equipment system. Frick can provide either a mechanical or solid-state electronic vibration cutout switch in a NEMA 4 enclosure to ensure reliable protection. Additional contacts can be provided to activate an alarm.

Single-Point Wiring (Option)

Frick offers the option for Single-point Wiring on XLP2 condensers. Single-point wiring decreases installation time by routing wires, from motors (fan and pump) and options such as VCOS, EWLC and basin heaters, in UL-listed conduit to a stainless steel NEMA 3R electrical box.

Electric Water Level Control Package (Option)

The electric water level control replaces the standard mechanical makeup valve when a more precise water level control is required. This package consists of a conductance-actuated level control mounted in the basin and a solenoid activated valve in the makeup water line. The valve is slow closing to minimize water hammer.

Basin Heaters (Option)

XLP2 Evaporative Condensers exposed to below freezing ambient temperatures require protection to prevent freezing of the water in the cold water basin when the unit is idle. Factory installed electric immersion heaters, which maintain +40°F (4.4°C) water temperature, are a simple and inexpensive way of providing such protection.

Basin Sweeper Piping (Option)

Basin sweeper piping is an effective method of eliminating sediment that may collect in the cold water basin of the unit. A piping system is provided for connection to side stream filtration equipment (by others).

Solid Bottom Panels (Option)

Factory-installed bottom panels are required when intake air is ducted to the unit.

Steel Eliminators (Option)

Steel eliminators are available as an option.

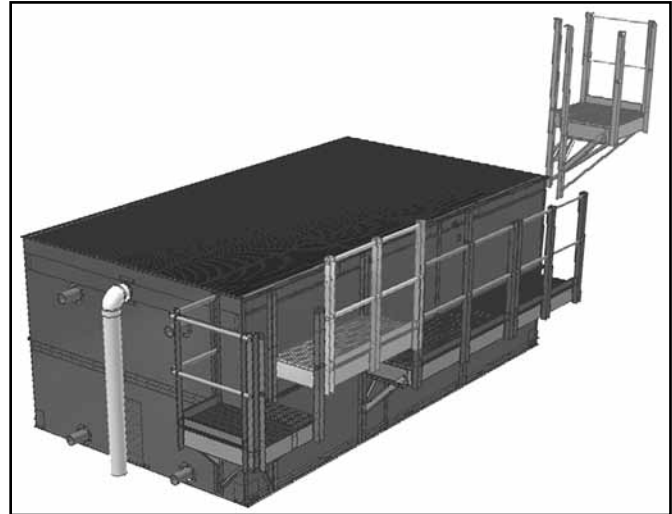

Pre-Assembled External Platform Sections



Variable Frequency Drive



Basin Heater

Table 1: Heater kW Data

Model Numbers	0°F (-17.8°C) Ambient Heaters		-20°F (-28.9°C) Ambient Heaters	
	No. of Heaters	kW per Heater	No. of Heaters	kW per Heater
XLP2-512-130 thru 512-203	1	6	1	8
XLP2-712-164 thru 712-276	1	8	1	10
XLP2-812-235 thru 812-343	1	8	1	12
XLP2-818-320 thru 818-474	1	12	1	18
XLP2-1012-282 thru 1012-545	1	8	1	10
XLP2-1018-433 thru 1018-729	1	12	1	15
XLP2-1024-564 thru 1024-1089	2	8	2	10
XLP2-1036-866 thru 1036-1658	2	12	2	15
XLP2-1212-321 thru 1212-703	1	10	1	15
XLP2-1218-495 thru 1218-1075	1	15	1	18
XLP2-1224-644 thru 1224-1405	2	10	2	15
XLP2-1236-989 thru 1236-2148	2	15	2	18

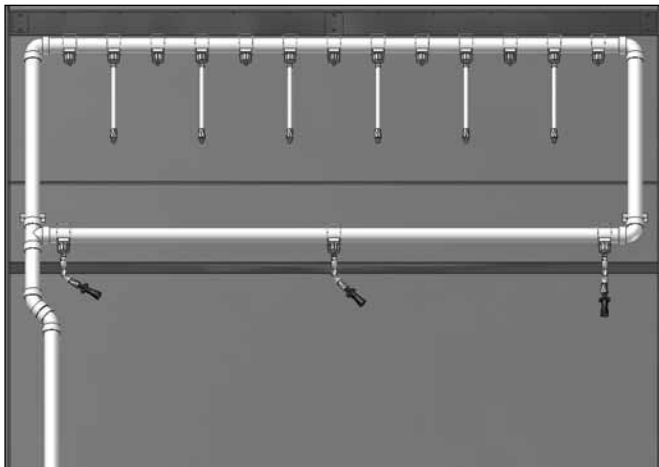

Basin Sweeper Piping

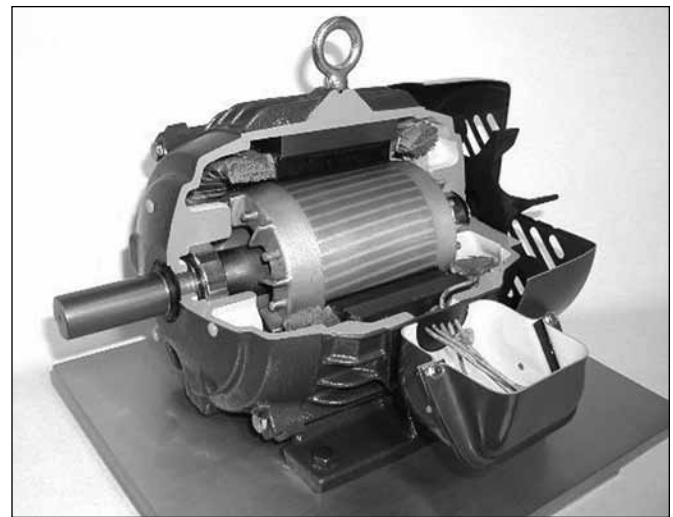

Premium Efficient Motors

Premium Efficient Motors

Federal and state regulations have been mandating minimum energy efficiencies for quite some time. The Energy Independence and Security Act of 2007, regulates most type of electric motors used in the industry which were previously excluded from minimum efficiency requirements.

To ensure our customers receive equipment compliant with the Energy Independence and Security Act of 2007, effective on December 19th, 2010, Energy Policy Act, and NEMA Standard MG 31, Section IV, Part 31, Frick will provide premium efficient fan motors ranging from 2 to 100 HP as standard on all products.

Motors are offered in both TEFC and TEAO configuration with a full range of voltages and orientations and a 5 year warranty. Premium efficient motors are inverter duty, therefore VFD ready. With premium efficiency motors as standard, a VFD can be added at a later time without having to upgrade the motors.

The use of premium efficient motors provides an opportunity for significant monetary savings through the equipment's life span due to average 8% higher operating efficiency and helps conserve natural resources, preserving the environment.

Structural Support

The recommended support arrangement for the XLP2 Evaporative Condenser consists of parallel I-beams running the full length of the unit. Besides providing adequate support, the steel also serves to raise the unit above any solid foundation which might restrict air movement or prevent access to the unit. The steel support beam must be level at the top. Support beams and anchor bolts are to be selected and installed by others. Refer to the Frick unit certified print for bolt hole location.

Beam Size and Length

Beam size should be calculated in accordance with accepted structural practice. Use 65 percent of the operating weight as a uniform load on each beam. The length of the beam must be at least equal to the length of the basin. Refer to the Engineering Data/Dimensions section for basin dimensions.

Maximum permissible beam deflection and center line distances between bolt holes are tabulated in the Table 2.

Table 2: Beam Data

Model Number	D	Max Deflection
XLP2-512-130 thru 512-203	4' 11½"	3/8"
XLP2-712-164 thru 712-276	6' 4¼"	3/8"
XLP2-812-235 thru 812-343	7' 8"	3/8"
XLP2-818-320 thru 818-474	7' 8"	1/2"
XLP2-1012-282 thru 1012-545	9' 7½"	3/8"
XLP2-1018-433 thru 1036-1658	9' 7½"	1/2"
XLP2-1212-321 thru 1212-703	11' 7¼"	3/8"
XLP2-1218-495 thru 1236-2148	11' 7¼"	1/2"

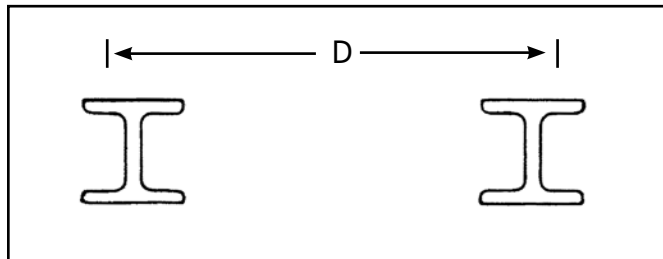

Selection

Two methods of unit selection are provided on the following pages. The heat rejection method is always recommended and the selection can be made via Frick's free product selection software, or manually as described below.

NOTE: Consult your local Frick Representative for evaporative condenser selections for systems utilizing the following:

- Hydrocarbon refrigerants such as propane, butane, or propylene
- Centrifugal compressors
- Rotary screw compressors with water cooled oil coolers
- Ammonia evaporative condensers with desuperheaters

- Halocarbon evaporative condensers with subcooling

Heat Rejection Method

In a mechanical refrigeration system, the function of an evaporative condenser is to reject heat to the environment. The heat to be rejected is the sum of the heat input at the evaporator and the energy input at the compressor. For a given set of operating conditions, the energy input through the compression process can vary. Therefore, in order to accurately determine the proper evaporative condenser required, it is necessary to establish the compressor energy input as well as the heat absorbed in the evaporator.

Selection Procedure

The Base Heat Rejection of the XLP2 Evaporative Condenser is shown in Table 3. Tables 4 and 5 present capacity factors to be applied to the system heat rejection for various condensing temperatures, entering wet-bulbs, and refrigerants.

1. Establish total heat rejection required in thousands of BTU per hour (MBH): Total heat rejection = compressor evaporator capacity (MBH) + compressor BHP x 2,545.
2. Determine the refrigerant and design conditions for condensing temperature and entering wet-bulb temperature.
3. Using the appropriate table for the system refrigerant and model (Tables 4 or 5), determine the capacity factor for the design condensing temperature and entering wet-bulb temperature.
4. Multiply the total heat rejection by the capacity factor determined in Step 3.
5. From Table 3, select the evaporative condenser whose Base Heat Rejection equals or exceeds the corrected heat rejection calculated in Step 4.

Download free selection software at www.johnsoncontrols.com.

Table 3: Heat Rejection Capacity Factors – R-717 (Ammonia)

Condensing Pressure (psig) R-717	Condensing Temp (°F)	Entering Wet-Bulb Temperature (°F)																
		50	52	54	56	58	60	62	64	66	68	70	72	74	76	78	80	82
151.3	85	0.97	1.01	1.06	1.11	1.17	1.25	1.33	1.43	1.55	1.70	1.89	2.14	2.47	2.97	3.73	-	-
154.1	86	0.94	0.98	1.02	1.07	1.13	1.19	1.27	1.36	1.46	1.60	1.76	1.97	2.26	2.66	3.26	4.25	-
156.9	87	0.91	0.95	0.99	1.03	1.08	1.14	1.21	1.29	1.39	1.51	1.65	1.83	2.08	2.40	2.88	3.63	-
159.8	88	0.88	0.91	0.95	0.99	1.04	1.10	1.16	1.23	1.32	1.42	1.55	1.71	1.92	2.20	2.58	3.16	4.13
162.6	89	0.85	0.89	0.92	0.96	1.00	1.05	1.11	1.18	1.26	1.35	1.46	1.60	1.78	2.02	2.34	2.80	3.53
165.5	90	0.83	0.86	0.89	0.93	0.97	1.01	1.07	1.13	1.20	1.28	1.38	1.51	1.67	1.87	2.13	2.51	3.08
168.5	91	0.80	0.83	0.86	0.90	0.93	0.98	1.02	1.08	1.14	1.22	1.31	1.42	1.56	1.73	1.96	2.27	2.72
171.5	92	0.78	0.81	0.83	0.87	0.90	0.94	0.99	1.04	1.10	1.17	1.25	1.35	1.47	1.62	1.82	2.08	2.44
174.5	93	0.76	0.78	0.81	0.84	0.87	0.91	0.95	1.00	1.05	1.11	1.19	1.28	1.38	1.52	1.69	1.91	2.21
177.6	94	0.74	0.76	0.79	0.81	0.84	0.88	0.92	0.96	1.01	1.07	1.13	1.21	1.31	1.43	1.58	1.77	2.02
180.7	95	0.72	0.74	0.76	0.79	0.82	0.85	0.88	0.92	0.97	1.02	1.08	1.16	1.24	1.35	1.48	1.64	1.86
185.0	96.3	0.69	0.71	0.73	0.76	0.78	0.81	0.84	0.88	0.92	0.97	1.02	1.09	1.16	1.25	1.36	1.51	1.68
187.0	97	0.68	0.70	0.72	0.74	0.77	0.79	0.83	0.86	0.90	0.94	0.99	1.05	1.13	1.21	1.31	1.44	1.60
190.2	98	0.66	0.68	0.70	0.72	0.74	0.77	0.80	0.83	0.87	0.91	0.96	1.01	1.07	1.15	1.24	1.35	1.49
193.4	99	0.65	0.66	0.68	0.70	0.72	0.75	0.77	0.80	0.84	0.87	0.92	0.97	1.03	1.10	1.18	1.28	1.40
196.7	100	0.63	0.65	0.66	0.68	0.70	0.72	0.75	0.78	0.81	0.84	0.88	0.93	0.98	1.05	1.12	1.21	1.32
213.7	105	0.56	0.57	0.58	0.60	0.61	0.63	0.65	0.67	0.69	0.71	0.74	0.77	0.81	0.85	0.89	0.95	1.01
231.8	110	0.50	0.51	0.52	0.53	0.54	0.55	0.57	0.58	0.60	0.62	0.64	0.66	0.68	0.71	0.74	0.78	0.82

Table 4: Base Heat Rejection

Model Number	Base Heat Rejection
XLP2-512-130	1,793
XLP2-512-145	1,999
XLP2-512-147	2,029
XLP2-512-152	2,102
XLP2-512-160	2,205
XLP2-512-164	2,264
XLP2-512-171	2,367
XLP2-512-172	2,382
XLP2-512-181	2,499
XLP2-512-189	2,617
XLP2-512-194	2,676
XLP2-512-203	2,808
XLP2-712-164	2,264
XLP2-712-183	2,528
XLP2-712-185	2,558
XLP2-712-204	2,823
XLP2-712-207	2,867
XLP2-712-219	3,028
XLP2-712-229	3,161
XLP2-712-242	3,337
XLP2-712-250	3,455
XLP2-712-276	3,807
XLP2-812-235	3,249
XLP2-812-246	3,396
XLP2-812-260	3,587
XLP2-812-271	3,749
XLP2-812-278	3,837
XLP2-812-290	4,013
XLP2-812-306	4,234
XLP2-812-320	4,425
XLP2-812-328	4,528
XLP2-812-343	4,734
XLP2-818-320	4,425
XLP2-818-344	4,748
XLP2-818-356	4,925
XLP2-818-374	5,175
XLP2-818-379	5,233
XLP2-818-382	5,278
XLP2-818-401	5,542
XLP2-818-405	5,601
XLP2-818-421	5,821
XLP2-818-443	6,115
XLP2-818-451	6,233
XLP2-818-474	6,556
XLP2-1012-282	3,896
XLP2-1012-319	4,410
XLP2-1012-320	4,425
XLP2-1012-324	4,484
XLP2-1012-343	4,734
XLP2-1012-352	4,866
XLP2-1012-362	4,998
XLP2-1012-367	5,072
XLP2-1012-369	5,101
XLP2-1012-387	5,351
XLP2-1012-399	5,513
XLP2-1012-404	5,586
XLP2-1012-418	5,777
XLP2-1012-427	5,895
XLP2-1012-428	5,910
XLP2-1012-433	5,983
XLP2-1012-456	6,306
XLP2-1012-457	6,321
XLP2-1012-461	6,365

Model Number	Base Heat Rejection
XLP2-1012-482	6,659
XLP2-1012-494	6,821
XLP2-1012-503	6,953
XLP2-1012-521	7,203
XLP2-1012-545	7,527
XLP2-1018-433	5,983
XLP2-1018-480	6,630
XLP2-1018-489	6,762
XLP2-1018-500	6,909
XLP2-1018-519	7,174
XLP2-1018-539	7,453
XLP2-1018-543	7,497
XLP2-1018-564	7,791
XLP2-1018-565	7,806
XLP2-1018-578	7,982
XLP2-1018-587	8,115
XLP2-1018-596	8,232
XLP2-1018-622	8,600
XLP2-1018-637	8,806
XLP2-1018-638	8,820
XLP2-1018-648	8,953
XLP2-1018-660	9,114
XLP2-1018-695	9,600
XLP2-1018-696	9,614
XLP2-1018-702	9,702
XLP2-1018-733	10,129
XLP2-1018-752	10,393
XLP2-1018-793	10,944
XLP2-1018-829	11,452
XLP2-1024-564	7,791
XLP2-1024-638	8,820
XLP2-1024-640	8,850
XLP2-1024-649	8,967
XLP2-1024-660	9,115
XLP2-1024-668	9,236
XLP2-1024-685	9,467
XLP2-1024-704	9,732
XLP2-1024-706	9,751
XLP2-1024-723	9,996
XLP2-1024-734	10,143
XLP2-1024-738	10,202
XLP2-1024-745	10,296
XLP2-1024-756	10,448
XLP2-1024-775	10,702
XLP2-1024-798	11,025
XLP2-1024-799	11,023
XLP2-1024-809	11,172
XLP2-1024-822	11,356
XLP2-1024-833	11,508
XLP2-1024-836	11,555
XLP2-1024-853	11,790
XLP2-1024-855	11,819
XLP2-1024-866	11,966
XLP2-1024-879	12,144
XLP2-1024-881	12,174
XLP2-1024-892	12,325
XLP2-1024-913	12,613
XLP2-1024-915	12,643
XLP2-1024-921	12,731
XLP2-1024-940	12,991
XLP2-1024-964	13,319
XLP2-1024-987	13,642
XLP2-1024-1006	13,907

Model Number	Base Heat Rejection
XLP2-1024-1043	14,407
XLP2-1024-1089	15,053
XLP2-1036-866	11,966
XLP2-1036-960	13,260
XLP2-1036-979	13,525
XLP2-1036-1000	13,819
XLP2-1036-1038	14,348
XLP2-1036-1079	14,906
XLP2-1036-1085	14,995
XLP2-1036-1128	15,583
XLP2-1036-1130	15,612
XLP2-1036-1155	15,965
XLP2-1036-1175	16,229
XLP2-1036-1192	16,465
XLP2-1036-1245	17,200
XLP2-1036-1275	17,611
XLP2-1036-1277	17,641
XLP2-1036-1296	17,905
XLP2-1036-1319	18,229
XLP2-1036-1389	19,199
XLP2-1036-1392	19,228
XLP2-1036-1404	19,405
XLP2-1036-1466	20,257
XLP2-1036-1504	20,787
XLP2-1036-1587	21,933
XLP2-1036-1658	22,904
XLP2-1212-321	4,440
XLP2-1212-359	4,954
XLP2-1212-364	5,028
XLP2-1212-376	5,189
XLP2-1212-390	5,395
XLP2-1212-401	5,542
XLP2-1212-405	5,601
XLP2-1212-424	5,865
XLP2-1212-427	5,895
XLP2-1212-430	5,939
XLP2-1212-442	6,101
XLP2-1212-447	6,174
XLP2-1212-453	6,262
XLP2-1212-468	6,468
XLP2-1212-480	6,630
XLP2-1212-483	6,674
XLP2-1212-487	6,733
XLP2-1212-501	6,924
XLP2-1212-506	6,997
XLP2-1212-522	7,218
XLP2-1212-523	7,226
XLP2-1212-533	7,365
XLP2-1212-546	7,541
XLP2-1212-551	7,615
XLP2-1212-571	7,894
XLP2-1212-576	7,953
XLP2-1212-597	8,247
XLP2-1212-617	8,526
XLP2-1212-622	8,600
XLP2-1212-666	9,203
XLP2-1212-703	9,717
XLP2-1218-495	6,836
XLP2-1218-548	7,571
XLP2-1218-560	7,733
XLP2-1218-566	7,821
XLP2-1218-597	8,247
XLP2-1218-618	8,541

Model Number	Base Heat Rejection
XLP2-1218-619	8,556
XLP2-1218-640	8,850
XLP2-1218-648	8,953
XLP2-1218-663	9,158
XLP2-1218-676	9,335
XLP2-1218-683	9,438
XLP2-1218-699	9,658
XLP2-1218-706	9,761
XLP2-1218-732	10,114
XLP2-1218-733	10,129
XLP2-1218-745	10,290
XLP2-1218-756	10,452
XLP2-1218-772	10,673
XLP2-1218-798	11,025
XLP2-1218-800	11,055
XLP2-1218-809	11,172
XLP2-1218-835	11,540
XLP2-1218-843	11,643
XLP2-1218-867	11,981
XLP2-1218-880	12,157
XLP2-1218-915	12,643
XLP2-1218-944	13,039
XLP2-1218-952	13,157
XLP2-1218-1018	14,068
XLP2-1218-1075	14,848
XLP2-1224-644	8,894
XLP2-1224-717	9,908
XLP2-1224-728	10,055
XLP2-1224-743	10,261
XLP2-1224-751	10,379
XLP2-1224-775	10,702
XLP2-1224-782	10,805
XLP2-1224-802	11,084
XLP2-1224-811	11,202
XLP2-1224-812	11,218
XLP2-1224-839	11,599
XLP2-1224-849	11,731
XLP2-1224-856	11,834
XLP2-1224-860	11,878
XLP2-1224-876	12,099
XLP2-1224-884	12,216
XLP2-1224-894	12,348
XLP2-1224-906	12,525
XLP2-1224-917	12,672
XLP2-1224-926	12,789
XLP2-1224-935	12,922
XLP2-1224-960	13,260
XLP2-1224-965	13,333
XLP2-1224-968	13,378
XLP2-1224-975	13,466
XLP2-1224-992	13,701
XLP2-1224-1002	13,848
XLP2-1224-1012	13,980
XLP2-1224-1013	13,995
XLP2-1224-1034	14,289
XLP2-1224-1045	14,436
XLP2-1224-1046	14,448
XLP2-1224-1064	14,701
XLP2-1224-1067	14,745
XLP2-1224-1084	14,980
XLP2-1224-1090	15,068
XLP2-1224-1092	15,083
XLP2-1224-1102	15,230

Model Number	Base Heat Rejection
XLP2-1224-1139	15,744
XLP2-1224-1144	15,803
XLP2-1224-1151	15,906
XLP2-1224-1194	16,494
XLP2-1224-1196	16,523
XLP2-1224-1234	17,053
XLP2-1224-1245	17,200
XLP2-1224-1281	17,699
XLP2-1224-1332	18,405
XLP2-1224-1405	19,420
XLP2-1236-989	13,671
XLP2-1236-1096	15,142
XLP2-1236-1119	15,465
XLP2-1236-1133	15,656
XLP2-1236-1195	16,509
XLP2-1236-1236	17,082
XLP2-1236-1239	17,126
XLP2-1236-1281	17,699
XLP2-1236-1298	17,935
XLP2-1236-1326	18,317
XLP2-1236-1351	18,670
XLP2-1236-1366	18,876
XLP2-1236-1399	19,331
XLP2-1236-1412	19,508
XLP2-1236-1464	20,228
XLP2-1236-1468	20,287
XLP2-1236-1489	20,581
XLP2-1236-1513	20,904
XLP2-1236-1545	21,345
XLP2-1236-1597	22,066
XLP2-1236-1600	22,110
XLP2-1236-1619	22,374
XLP2-1236-1670	23,080
XLP2-1236-1684	23,271
XLP2-1236-1735	23,977
XLP2-1236-1760	24,315
XLP2-1236-1831	25,300
XLP2-1236-1887	26,079
XLP2-1236-1904	26,314
XLP2-1236-2036	28,137
XLP2-1236-2148	29,681

Selection Example

Given:

R-717 refrigerant

Compressor evaporator capacity = 550 tons

Compressor BHP = 600

Condensing temperature = 95°F

Entering wet-bulb temperature = 76°F

Solution:

- Determine the total heat rejection:
Compressor evaporator capacity =
550 TR x 12,000 BTUH/TR = 6,600,000 BTUH

Compressor BHP input =

$$600 \text{ BHP} \times 2,545 \text{ BTUH/BHP} = 1,527,000 \text{ BTUH}$$

Total heat rejection = 8,127,000 BTUH = 8,127 MBH

- From Table 3, the heat rejection capacity factor for R-717 at 95°F condensing temperature and 76°F entering wet-bulb temperature is 1.35.
- Multiply: 8,127 MBH x 1.35 = 10,972 MBH
- From Table 4 select a unit with a Base Heat Rejection equal to or greater than 10,972 MBH:
Model XLP2-1024-798.

Table 5: Heat Rejection Capacity Factors – R-134a

Condensing Pressure (psig) R-134a	Condensing Temp (°F)	Entering Wet-Bulb Temperature (°F)																
		50	52	54	56	58	60	62	64	66	68	70	72	74	76	78	80	82
95.2	85	1.09	1.14	1.19	1.25	1.32	1.40	1.49	1.60	1.74	1.91	2.12	2.40	2.78	3.33	-	-	-
97.1	86	1.06	1.10	1.15	1.20	1.27	1.34	1.42	1.52	1.64	1.79	1.98	2.22	2.54	2.98	3.66	4.78	-
98.9	87	1.02	1.06	1.11	1.16	1.22	1.28	1.36	1.45	1.56	1.69	1.85	2.06	2.33	2.70	3.24	4.08	-
100.7	88	0.99	1.03	1.07	1.12	1.17	1.23	1.30	1.38	1.48	1.60	1.74	1.92	2.16	2.47	2.90	3.56	4.65
102.6	89	0.96	0.99	1.03	1.08	1.13	1.18	1.25	1.32	1.41	1.52	1.64	1.80	2.00	2.27	2.63	3.15	3.97
104.3	90	0.93	0.96	1.00	1.04	1.09	1.14	1.20	1.27	1.35	1.44	1.56	1.70	1.87	2.10	2.40	2.82	3.46
106.2	91	0.90	0.93	0.97	1.01	1.05	1.10	1.15	1.21	1.29	1.37	1.47	1.60	1.75	1.95	2.20	2.55	3.06
108.1	92	0.88	0.91	0.94	0.97	1.01	1.06	1.11	1.16	1.23	1.31	1.40	1.51	1.65	1.82	2.04	2.33	2.74
110.0	93	0.85	0.88	0.91	0.94	0.98	1.02	1.07	1.12	1.18	1.25	1.33	1.43	1.56	1.71	1.90	2.14	2.49
111.9	94	0.83	0.85	0.88	0.91	0.95	0.98	1.03	1.08	1.13	1.20	1.27	1.35	1.47	1.60	1.77	1.98	2.27
113.9	95	0.81	0.83	0.86	0.88	0.92	0.95	0.99	1.04	1.09	1.15	1.22	1.30	1.40	1.51	1.66	1.84	2.09
115.9	96	0.79	0.81	0.83	0.86	0.89	0.92	0.96	1.00	1.05	1.10	1.17	1.24	1.33	1.43	1.56	1.72	1.93
117.5	97	0.76	0.79	0.81	0.83	0.86	0.89	0.93	0.97	1.01	1.06	1.12	1.18	1.26	1.36	1.47	1.61	1.80
119.9	98	0.75	0.76	0.79	0.81	0.84	0.86	0.90	0.93	0.97	1.02	1.07	1.13	1.21	1.29	1.39	1.52	1.68
122.1	99	0.73	0.74	0.77	0.79	0.81	0.84	0.87	0.90	0.94	0.98	1.03	1.09	1.15	1.23	1.32	1.43	1.57
124.1	100	0.71	0.73	0.74	0.77	0.79	0.81	0.84	0.87	0.91	0.95	0.99	1.04	1.10	1.17	1.26	1.36	1.48
149.6	105	0.63	0.64	0.66	0.67	0.69	0.71	0.73	0.75	0.77	0.80	0.83	0.87	0.91	0.95	1.00	1.07	1.14
146.4	110	0.56	0.57	0.58	0.60	0.61	0.62	0.64	0.65	0.67	0.69	0.71	0.74	0.77	0.85	0.83	0.87	0.92

Evaporator Ton Method

This selection method is based on estimated horsepower requirements for open reciprocating compressors only, and cannot be considered to be precise. Critical selection of this type should be checked by the heat rejection method shown in the "Selection" section.

Selection Procedure

- Determine the evaporator capacity in Refrigeration Tons (one Refrigeration Ton = 12,000 BTUH)
- Determine refrigerant and design conditions of condensing temperature, suction temperature, and entering wet-bulb temperature.
- Using tables appropriate for the system refrigerant, determine two correction factors: the Evaporator Capacity Factor (Table 7 and 8) and the Suction Temperature Factor (Tables 9 and 10).
- Multiply the evaporator capacity in tons by the two correction factors determined in Step 3.
- From Table 6 select an evaporative condenser whose model number equals or exceeds the product (factors x tons) calculated in Step 4.

NOTES: Consult your Frick Representative for evaporative condenser selections for systems utilizing refrigerants other than R-717 or R-134a and systems requiring special considerations, such as screw compressors with water cooled oil coolers, evaporative condensers with ammonia desuperheaters or halocarbon subcooling.

Selection Example: Screw Compressor

Given: R-134a refrigerant
Evaporator capacity = 145 tons
Condensing temperature = 105°F
Suction temperature = 30°F
Entering wet-bulb temperature = 80°F

Solution:

- From Table 8, the capacity factor for R-134a at 105°F condensing temperature and 80°F entering wet-bulb is 1.07.
- From Table 10, the capacity factor for R-134a at 30°F suction temperature is 1.03.
- Multiply 145 x 1.07 x 1.03 = 159.8 corrected tons.
- From Table 6, select a unit with Corrected Evaporator Tons equal or greater to 159.8: Model XLP2-512-171.

Table 6: Base Corrected Evaporator Tons

Model Number	Corrected Evaporator Tons	Model Number	Corrected Evaporator Tons	Model Number	Corrected Evaporator Tons	Model Number	Corrected Evaporator Tons	Model Number	Corrected Evaporator Tons
XLP2-512-130	87	XLP2-1012-482	321	XLP2-1024-1043	695	XLP2-1218-619	413	XLP2-1224-1139	760
XLP2-512-145	98	XLP2-1012-494	329	XLP2-1024-1089	726	XLP2-1218-640	427	XLP2-1224-1144	762
XLP2-512-147	96	XLP2-1012-503	335	XLP2-1036-866	577	XLP2-1218-648	432	XLP2-1224-1151	767
XLP2-512-152	106	XLP2-1012-521	348	XLP2-1036-960	640	XLP2-1218-663	442	XLP2-1224-1194	796
XLP2-512-160	109	XLP2-1012-545	363	XLP2-1036-979	653	XLP2-1218-676	450	XLP2-1224-1196	797
XLP2-512-164	114	XLP2-1018-433	289	XLP2-1036-1000	667	XLP2-1218-683	455	XLP2-1224-1234	823
XLP2-512-171	121	XLP2-1018-480	320	XLP2-1036-1038	692	XLP2-1218-699	466	XLP2-1224-1245	830
XLP2-512-172	101	XLP2-1018-489	326	XLP2-1036-1079	719	XLP2-1218-706	471	XLP2-1224-1281	854
XLP2-512-181	115	XLP2-1018-500	333	XLP2-1036-1085	723	XLP2-1218-732	488	XLP2-1224-1332	888
XLP2-512-189	126	XLP2-1018-519	346	XLP2-1036-1128	752	XLP2-1218-733	489	XLP2-1224-1405	937
XLP2-512-194	129	XLP2-1018-539	360	XLP2-1036-1130	753	XLP2-1218-745	496	XLP2-1236-989	660
XLP2-512-203	135	XLP2-1018-543	362	XLP2-1036-1155	770	XLP2-1218-756	504	XLP2-1236-1096	731
XLP2-712-164	109	XLP2-1018-564	376	XLP2-1036-1175	783	XLP2-1218-772	515	XLP2-1236-1119	746
XLP2-712-183	123	XLP2-1018-565	377	XLP2-1036-1192	794	XLP2-1218-798	532	XLP2-1236-1133	755
XLP2-712-185	136	XLP2-1018-578	385	XLP2-1036-1245	830	XLP2-1218-800	533	XLP2-1236-1195	797
XLP2-712-204	122	XLP2-1018-587	392	XLP2-1036-1275	850	XLP2-1218-809	539	XLP2-1236-1236	824
XLP2-712-207	138	XLP2-1018-596	397	XLP2-1036-1277	851	XLP2-1218-835	557	XLP2-1236-1239	826
XLP2-712-219	146	XLP2-1018-622	415	XLP2-1036-1296	864	XLP2-1218-843	562	XLP2-1236-1281	854
XLP2-712-229	161	XLP2-1018-637	425	XLP2-1036-1319	879	XLP2-1218-867	578	XLP2-1236-1298	865
XLP2-712-242	152	XLP2-1018-638	426	XLP2-1036-1389	926	XLP2-1218-880	587	XLP2-1236-1326	884
XLP2-712-250	167	XLP2-1018-648	432	XLP2-1036-1392	928	XLP2-1218-915	610	XLP2-1236-1351	901
XLP2-712-276	184	XLP2-1018-660	440	XLP2-1036-1404	936	XLP2-1218-944	629	XLP2-1236-1366	911
XLP2-812-235	157	XLP2-1018-695	463	XLP2-1036-1466	977	XLP2-1218-952	635	XLP2-1236-1399	933
XLP2-812-246	173	XLP2-1018-696	464	XLP2-1036-1504	1003	XLP2-1218-1018	679	XLP2-1236-1412	941
XLP2-812-260	185	XLP2-1018-702	468	XLP2-1036-1587	1058	XLP2-1218-1075	716	XLP2-1236-1464	976
XLP2-812-271	164	XLP2-1018-733	489	XLP2-1036-1658	1105	XLP2-1224-644	429	XLP2-1236-1468	979
XLP2-812-278	181	XLP2-1018-752	501	XLP2-1212-321	214	XLP2-1224-717	478	XLP2-1236-1489	993
XLP2-812-290	194	XLP2-1018-793	529	XLP2-1212-359	239	XLP2-1224-728	485	XLP2-1236-1513	1009
XLP2-812-306	204	XLP2-1018-829	553	XLP2-1212-364	243	XLP2-1224-743	495	XLP2-1236-1545	1030
XLP2-812-320	213	XLP2-1024-564	376	XLP2-1212-376	250	XLP2-1224-751	501	XLP2-1236-1597	1065
XLP2-812-328	218	XLP2-1024-638	426	XLP2-1212-390	260	XLP2-1224-775	516	XLP2-1236-1600	1067
XLP2-812-343	228	XLP2-1024-640	427	XLP2-1212-401	267	XLP2-1224-782	521	XLP2-1236-1619	1079
XLP2-818-320	213	XLP2-1024-649	433	XLP2-1212-405	270	XLP2-1224-802	535	XLP2-1236-1670	1114
XLP2-818-344	229	XLP2-1024-660	440	XLP2-1212-424	283	XLP2-1224-811	540	XLP2-1236-1684	1123
XLP2-818-356	252	XLP2-1024-668	446	XLP2-1212-427	284	XLP2-1224-812	541	XLP2-1236-1735	1157
XLP2-818-374	270	XLP2-1024-685	457	XLP2-1212-430	287	XLP2-1224-839	560	XLP2-1236-1760	1173
XLP2-818-379	238	XLP2-1024-704	470	XLP2-1212-442	294	XLP2-1224-849	566	XLP2-1236-1831	1221
XLP2-818-382	255	XLP2-1024-706	470	XLP2-1212-447	298	XLP2-1224-856	571	XLP2-1236-1887	1258
XLP2-818-401	250	XLP2-1024-723	482	XLP2-1212-453	302	XLP2-1224-860	573	XLP2-1236-1904	1270
XLP2-818-405	267	XLP2-1024-734	489	XLP2-1212-468	312	XLP2-1224-876	584	XLP2-1236-2036	1358
XLP2-818-421	281	XLP2-1024-738	492	XLP2-1212-480	320	XLP2-1224-884	589	XLP2-1236-2148	1432
XLP2-818-443	295	XLP2-1024-745	497	XLP2-1212-483	322	XLP2-1224-894	596		
XLP2-818-451	301	XLP2-1024-756	504	XLP2-1212-487	325	XLP2-1224-906	604		
XLP2-818-474	316	XLP2-1024-775	516	XLP2-1212-501	334	XLP2-1224-917	611		
XLP2-1012-282	188	XLP2-1024-798	532	XLP2-1212-506	338	XLP2-1224-926	617		
XLP2-1012-319	213	XLP2-1024-799	533	XLP2-1212-522	348	XLP2-1224-935	623		
XLP2-1012-320	235	XLP2-1024-809	539	XLP2-1212-523	349	XLP2-1224-960	640		
XLP2-1012-324	213	XLP2-1024-822	548	XLP2-1212-533	355	XLP2-1224-965	643		
XLP2-1012-343	216	XLP2-1024-833	555	XLP2-1212-546	364	XLP2-1224-968	645		
XLP2-1012-352	228	XLP2-1024-836	557	XLP2-1212-551	367	XLP2-1224-975	650		
XLP2-1012-362	241	XLP2-1024-853	569	XLP2-1212-571	381	XLP2-1224-992	661		
XLP2-1012-367	245	XLP2-1024-855	570	XLP2-1212-576	384	XLP2-1224-1002	668		
XLP2-1012-369	246	XLP2-1024-866	577	XLP2-1212-597	398	XLP2-1224-1012	675		
XLP2-1012-387	258	XLP2-1024-879	586	XLP2-1212-617	411	XLP2-1224-1013	675		
XLP2-1012-399	266	XLP2-1024-881	587	XLP2-1212-622	415	XLP2-1224-1034	689		
XLP2-1012-404	270	XLP2-1024-892	595	XLP2-1212-666	444	XLP2-1224-1045	696		
XLP2-1012-418	279	XLP2-1024-913	609	XLP2-1212-703	469	XLP2-1224-1046	697		
XLP2-1012-427	284	XLP2-1024-915	610	XLP2-1218-495	330	XLP2-1224-1064	709		
XLP2-1012-428	285	XLP2-1024-921	614	XLP2-1218-548	365	XLP2-1224-1067	711		
XLP2-1012-433	289	XLP2-1024-940	627	XLP2-1218-560	373	XLP2-1224-1084	723		
XLP2-1012-456	304	XLP2-1024-964	643	XLP2-1218-566	377	XLP2-1224-1090	727		
XLP2-1012-457	305	XLP2-1024-987	658	XLP2-1218-597	398	XLP2-1224-1092	728		
XLP2-1012-461	307	XLP2-1024-1006	671	XLP2-1218-618	412	XLP2-1224-1102	735		

Table 7: Evaporator Capacity Factors – R-717 (Ammonia)

Condensing Pressure (psig) R-717	Condensing Temp (°F)	Entering Wet-Bulb Temperature (°F)																
		50	52	54	56	58	60	62	64	66	68	70	72	74	76	78	80	82
151.7	85	0.98	1.02	1.07	1.12	1.18	1.26	1.34	1.44	1.56	1.71	1.90	2.15	2.50	2.99	-	-	-
154.1	86	0.95	0.99	1.03	1.08	1.14	1.20	1.28	1.37	1.48	1.61	1.78	1.99	2.28	2.68	3.29	4.30	-
156.9	87	0.92	0.96	1.00	1.04	1.10	1.16	1.23	1.31	1.41	1.52	1.67	1.86	2.10	2.44	2.92	3.68	-
159.8	88	0.90	0.93	0.97	1.01	1.06	1.11	1.18	1.25	1.34	1.45	1.58	1.74	1.95	2.23	2.62	3.21	4.20
162.6	89	0.87	0.90	0.94	0.98	1.02	1.07	1.13	1.20	1.28	1.37	1.49	1.63	1.82	2.05	2.38	2.85	3.59
165.9	90	0.85	0.88	0.91	0.95	0.99	1.03	1.09	1.15	1.22	1.31	1.41	1.54	1.70	1.91	2.18	2.56	3.14
168.9	91	0.82	0.85	0.88	0.92	0.95	1.00	1.05	1.11	1.17	1.25	1.34	1.46	1.60	1.78	2.01	2.33	2.79
171.9	92	0.80	0.83	0.86	0.89	0.92	0.96	1.01	1.06	1.12	1.20	1.28	1.38	1.51	1.66	1.86	2.13	2.51
174.9	93	0.78	0.81	0.83	0.86	0.90	0.93	0.98	1.02	1.08	1.15	1.22	1.31	1.42	1.56	1.74	1.96	2.27
178.0	94	0.76	0.78	0.81	0.84	0.87	0.90	0.94	0.99	1.04	1.10	1.17	1.25	1.35	1.47	1.62	1.82	2.08
181.1	95	0.74	0.76	0.79	0.81	0.84	0.88	0.91	0.95	1.00	1.06	1.12	1.19	1.28	1.39	1.53	1.70	1.92
185.0	96.3	0.72	0.74	0.76	0.79	0.81	0.84	0.88	0.91	0.96	1.01	1.06	1.13	1.21	1.30	1.41	1.56	1.74
187.4	97	0.71	0.73	0.75	0.77	0.80	0.82	0.86	0.89	0.93	0.98	1.03	1.10	1.17	1.26	1.36	1.49	1.66
190.6	98	0.69	0.71	0.73	0.75	0.77	0.80	0.83	0.86	0.90	0.95	0.99	1.05	1.12	1.20	1.29	1.41	1.55
193.9	99	0.67	0.69	0.71	0.73	0.75	0.78	0.81	0.84	0.87	0.91	0.96	1.01	1.07	1.14	1.23	1.33	1.46
197.2	100	0.66	0.68	0.69	0.71	0.73	0.76	0.78	0.81	0.85	0.88	0.92	0.97	1.03	1.09	1.17	1.26	1.38
214.2	105	0.59	0.61	0.62	0.63	0.65	0.67	0.69	0.71	0.73	0.76	0.79	0.82	0.86	0.90	0.95	1.00	1.07
232.3	110	0.54	0.55	0.56	0.57	0.58	0.59	0.61	0.62	0.64	0.66	0.68	0.71	0.73	0.76	0.79	0.83	0.88

Table 8: Evaporator Capacity Factors – R-134a

Condensing Pressure (psig) R-134a	Condensing Temp (°F)	Entering Wet-Bulb Temperature (°F)																
		50	52	54	56	58	60	62	64	66	68	70	72	74	76	78	80	82
95.2	85	1.04	1.09	1.14	1.19	1.26	1.33	1.42	1.53	1.66	1.82	2.02	2.29	2.65	3.18	-	-	-
97.1	86	1.01	1.05	1.10	1.15	1.21	1.28	1.36	1.46	1.57	1.71	1.89	2.12	2.42	2.85	3.49	4.57	-
98.9	87	0.98	1.02	1.06	1.11	1.16	1.23	1.30	1.39	1.49	1.62	1.78	1.97	2.23	2.59	3.10	3.91	-
100.7	88	0.95	0.99	1.03	1.07	1.12	1.18	1.25	1.33	1.42	1.53	1.67	1.85	2.07	2.37	2.79	3.41	4.46
102.6	89	0.92	0.96	0.99	1.04	1.08	1.14	1.20	1.27	1.36	1.46	1.58	1.73	1.93	2.18	2.53	3.03	3.82
104.3	90	0.90	0.93	0.96	1.00	1.05	1.10	1.15	1.22	1.30	1.39	1.50	1.64	1.80	2.02	2.31	2.72	3.33
106.2	91	0.87	0.90	0.94	0.97	1.01	1.06	1.11	1.17	1.24	1.33	1.43	1.55	1.69	1.88	2.13	2.47	2.95
108.1	92	0.85	0.88	0.91	0.94	0.98	1.02	1.07	1.13	1.19	1.27	1.36	1.47	1.60	1.76	1.98	2.26	2.66
110.0	93	0.83	0.85	0.88	0.91	0.95	0.99	1.04	1.09	1.15	1.22	1.30	1.39	1.51	1.66	1.84	2.08	2.41
111.9	94	0.81	0.83	0.86	0.89	0.92	0.96	1.00	1.05	1.10	1.17	1.24	1.33	1.43	1.56	1.72	1.93	2.21
113.9	95	0.79	0.81	0.84	0.86	0.89	0.93	0.97	1.01	1.06	1.12	1.19	1.27	1.36	1.48	1.62	1.80	2.04
115.9	96	0.77	0.79	0.81	0.84	0.87	0.90	0.94	0.98	1.03	1.08	1.14	1.21	1.30	1.40	1.53	1.68	1.89
117.5	97	0.75	0.77	0.79	0.82	0.84	0.88	0.91	0.95	0.99	1.04	1.10	1.16	1.24	1.33	1.44	1.58	1.76
119.9	98	0.73	0.75	0.77	0.80	0.82	0.85	0.88	0.92	0.96	1.00	1.05	1.11	1.19	1.27	1.37	1.49	1.65
122.1	99	0.72	0.73	0.75	0.78	0.80	0.83	0.86	0.89	0.93	0.97	1.02	1.07	1.14	1.21	1.30	1.41	1.55
124.1	100	0.70	0.72	0.74	0.76	0.78	0.80	0.83	0.86	0.90	0.94	0.98	1.03	1.09	1.16	1.24	1.34	1.46
149.6	105	0.63	0.64	0.66	0.67	0.69	0.71	0.73	0.75	0.77	0.80	0.83	0.87	0.91	0.95	1.00	1.07	1.14
146.4	110	0.57	0.58	0.59	0.60	0.62	0.63	0.65	0.66	0.68	0.70	0.72	0.75	0.78	0.81	0.84	0.88	0.93

Table 9: Suction Temperature Factors – R-717 (Ammonia)

Suction Temperature (°F)	-20	-10	0	+10	+20	+30	+40	+50
Capacity Factor	1.14	1.11	1.07	1.04	1.00	0.98	0.95	0.93

Table 10: Suction Temperature Factors – R-134a

Suction Temperature (°F)	-20	-10	0	+10	+20	+30	+40	+50
Capacity Factor	1.20	1.16	1.13	1.09	1.06	1.03	1.00	0.98

Engineering Data/Dimensions

NOTE: Do not use for construction. Refer to factory certified dimensions. This handbook includes data current at the time of publication, which should be reconfirmed at the time of purchase. Up-to-date engineering data, free product selection software and more can be found at www.johnsoncontrols.com.

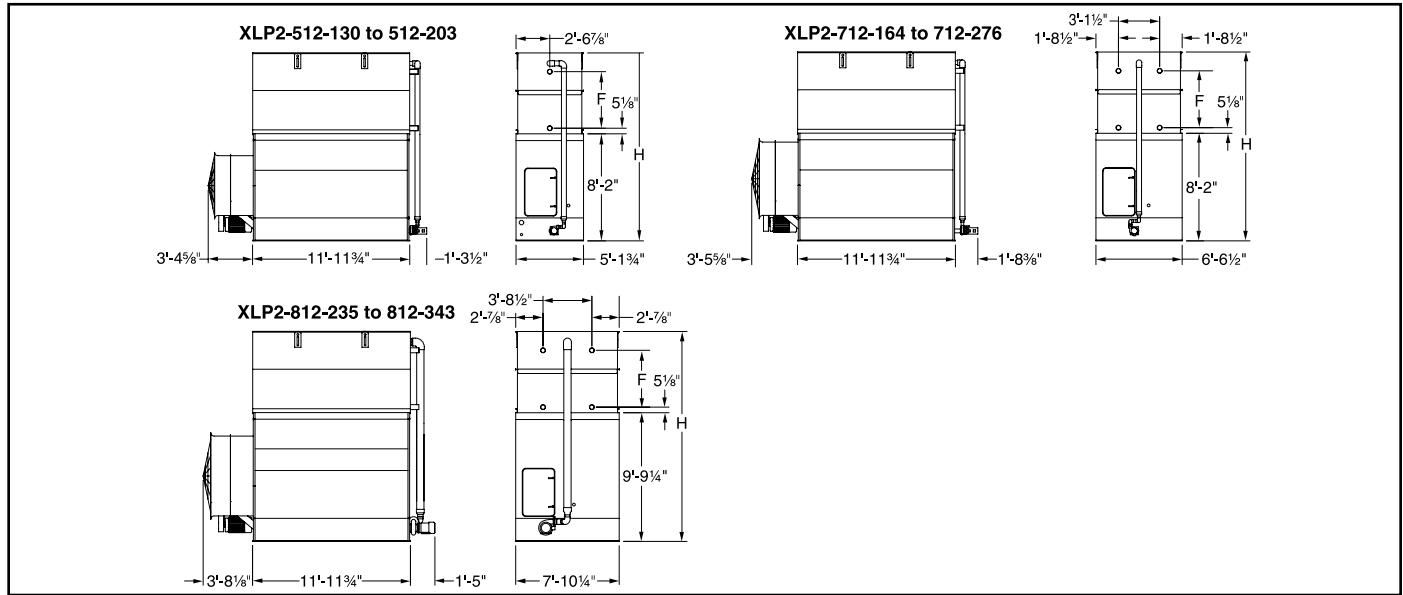

Nom Box Size	Model Number ¹	MBH ²	Evap Tons ³	Fan Motor (HP)	Airflow Rate (CFM)	Pump Motor (HP)	Spray Flow Rate (GPM)	Approximate Weights (lb)			R-717 Oper Charge (lb) ⁷	Internal Coil Volume (ft ³)	Remote Sump Bottom Connection			F	H
								Ship Weight (lb)	Heaviest Section (lb) ⁵	Oper Weight (lb) ⁴			Drain Size (in.)	Vol Req (gal.)	Approx. Oper Weight (lb)		
5 x 12	XLP2-512-130	1,300	87	3	23,800	1.5	260	6,390	4,350	9,490	184	20	(1) 6	239	7,490	2' 9 1/4"	12' 9 1/2"
5 x 12	XLP2-512-145	1,450	96	3	20,700	1.5	260	7,260	5,220	10,410	229	25	(1) 6	239	7,500	3' 6 1/2"	13' 6 3/4"
5 x 12	XLP2-512-147	1,470	98	5	25,900	1.5	260	6,400	4,350	9,500	184	20	(1) 6	239	8,410	2' 9 1/4"	12' 9 1/2"
5 x 12	XLP2-512-152	1,520	101	3	20,100	1.5	260	8,130	6,090	11,320	273	30	(1) 6	239	7,530	4' 3 3/4"	14' 4"
5 x 12	XLP2-512-160	1,600	106	7.5	28,300	1.5	260	6,430	4,350	9,530	184	20	(1) 6	239	8,420	2' 9 1/4"	12' 9 1/2"
5 x 12	XLP2-512-164	1,640	109	5	24,500	1.5	260	7,270	5,220	10,420	229	25	(1) 6	239	7,540	3' 6 1/2"	13' 6 3/4"
5 x 12	XLP2-512-171	1,710	114	10	31,100	1.5	260	6,440	4,350	9,540	184	20	(1) 6	239	8,450	2' 9 1/4"	12' 9 1/2"
5 x 12	XLP2-512-172	1,720	115	5	23,800	1.5	260	8,140	6,090	11,330	273	30	(1) 6	239	9,320	4' 3 3/4"	14' 4"
5 x 12	XLP2-512-181	1,810	121	7.5	28,000	1.5	260	7,300	5,220	10,450	229	25	(1) 6	239	9,330	3' 6 1/2"	13' 6 3/4"
5 x 12	XLP2-512-189	1,890	126	7.5	27,300	1.5	260	8,170	6,090	11,360	273	30	(1) 6	239	9,360	4' 3 3/4"	14' 4"
5 x 12	XLP2-512-194	1,940	129	10	30,800	1.5	260	7,310	5,220	10,460	229	25	(1) 6	239	8,460	3' 6 1/2"	13' 6 3/4"
5 x 12	XLP2-512-203	2,030	135	10	30,100	1.5	260	8,180	6,090	11,370	273	30	(1) 6	239	9,370	4' 3 3/4"	14' 4"
7 x 12	XLP2-712-164	1,640	109	3	26,500	2	330	8,470	5,770	12,260	240	52	(1) 8	197	8,730	2' 9 1/4"	12' 9 1/2"
7 x 12	XLP2-712-183	1,830	122	3	25,800	2	330	9,610	6,910	13,460	240	64	(1) 8	197	8,740	2' 9 1/4"	12' 9 1/2"
7 x 12	XLP2-712-185	1,850	123	5	31,400	2	330	8,170	5,770	11,960	240	52	(1) 8	197	8,770	2' 9 1/4"	12' 9 1/2"
7 x 12	XLP2-712-204	2,040	136	7.5	36,000	2	330	8,200	5,770	11,990	240	52	(1) 8	197	9,930	2' 9 1/4"	12' 9 1/2"
7 x 12	XLP2-712-207	2,070	138	5	30,600	2	330	9,310	6,910	13,160	240	64	(1) 8	197	9,940	2' 9 1/4"	13' 6 3/4"
7 x 12	XLP2-712-219	2,190	146	10	39,650	2	330	8,210	5,770	12,000	240	52	(1) 8	197	8,780	2' 9 1/4"	12' 9 1/2"
7 x 12	XLP2-712-229	2,290	152	7.5	35,050	2	330	9,340	6,910	13,190	298	64	(1) 8	197	8,850	3' 6 1/2"	13' 6 3/4"
7 x 12	XLP2-712-242	2,420	161	15	45,400	2	330	8,280	5,770	12,070	298	52	(1) 8	197	9,970	3' 6 1/2"	12' 9 1/2"
7 x 12	XLP2-712-250	2,500	167	10	38,750	2	330	9,350	6,910	13,200	298	64	(1) 8	197	9,980	3' 6 1/2"	13' 6 3/4"
7 x 12	XLP2-712-276	2,760	184	15	44,400	2	330	9,420	6,910	13,270	298	64	(1) 8	197	10,050	3' 6 1/2"	13' 6 3/4"
8 x 12	XLP2-812-235	2,350	157	5	34,400	3	400	11,690	8,170	16,200	362	78	(1) 8	243	12,520	3' 6 1/2"	15' 2"
8 x 12	XLP2-812-246	2,460	164	5	33,600	3	400	13,050	9,530	17,630	432	93	(1) 8	243	12,540	4' 3 3/4"	15' 11 1/4"
8 x 12	XLP2-812-260	2,600	173	7.5	39,400	3	400	11,710	8,170	16,220	362	78	(1) 8	243	12,550	3' 6 1/2"	15' 2"
8 x 12	XLP2-812-271	2,710	181	7.5	38,500	3	400	13,070	9,530	17,650	432	93	(1) 8	243	13,950	4' 3 3/4"	15' 11 1/4"
8 x 12	XLP2-812-278	2,780	185	10	43,400	3	400	11,720	8,170	16,230	362	78	(1) 8	243	13,970	3' 6 1/2"	15' 2"
8 x 12	XLP2-812-290	2,900	194	10	42,400	3	400	13,080	9,530	17,660	432	93	(1) 8	243	13,980	4' 3 3/4"	15' 11 1/4"
8 x 12	XLP2-812-306	3,060	204	15	49,700	3	400	11,800	8,170	16,310	362	78	(1) 8	243	12,630	3' 6 1/2"	15' 2"
8 x 12	XLP2-812-320	3,200	213	15	48,550	3	400	13,160	9,530	17,740	432	93	(1) 8	243	14,060	4' 3 3/4"	15' 11 1/4"
8 x 12	XLP2-812-328	3,280	218	20	54,700	3	400	11,830	8,170	16,340	362	78	(1) 8	243	12,660	3' 6 1/2"	15' 2"
8 x 12	XLP2-812-343	3,430	228	20	53,400	3	400	13,190	9,530	17,770	432	93	(1) 8	243	14,090	4' 3 3/4"	15' 11 1/4"

NOTES:

- Model number denotes condenser box size followed by nominal condenser capacity in MBH ÷ 10 at 96.3°F condensing and 78°F wet bulb; for example: XLP2-512-130 has 5' x 12' box size and 1,300 MBH.
- MBH at 96.3°F condensing and 78°F wet bulb with R-717.
- R-717 tons are at a 96.3°F condensing temperature, a 20°F suction temperature, and a 78°F entering wet-bulb temperature.
- Operating weight shown is based on total unit weight, weight of refrigerant operating charge, and cold water basin filled to the overflow level.
- Unless otherwise noted, the coil section is the heaviest section.
- Standard refrigerant connection size is 4" BFW (inlet and outlet).
- Refrigerant charge listed is R-717 operating charge. To determine operating charge for R-134a, multiply by 1.98.

NOTE: Do not use for construction. Refer to factory certified dimensions. This handbook includes data current at the time of publication, which should be reconfirmed at the time of purchase. Up-to-date engineering data, free product selection software and more can be found at www.johnsoncontrols.com.

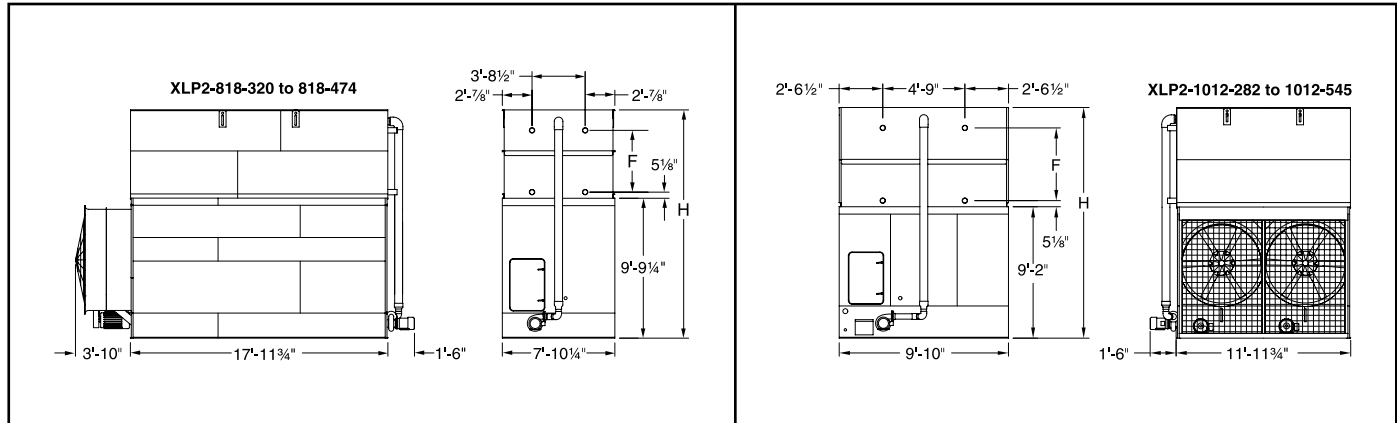

Nom Box Size	Model Number ¹	MBH ²	Evap Tons ³	Fan Motor (HP)	Airflow Rate (CFM)	Pump Motor (HP)	Spray Flow Rate (GPM)	Approximate Weights (lb)			R-717 Oper Charge (lb) ⁷	Internal Coil Volume (ft ³)	Remote Sump Bottom Connection			F	H
								Ship Weight (lb)	Heaviest Section (lb) ⁵	Oper Weight (lb) ⁴			Drain Size (in.)	Vol Req (gal.)	Approx. Oper Weight (lb)		
8 x 18	XLP2-818-320	3,200	213	7.5	53,700	5	600	14,980	9,810	21,700	435	94	(1) 10	332	16,140	2' 9 1/4"	14' 4 3/4"
8 x 18	XLP2-818-344	3,440	229	10	59,100	5	600	14,990	9,810	21,710	435	94	(1) 10	332	16,150	2' 9 1/4"	14' 4 3/4"
8 x 18	XLP2-818-356	3,560	238	7.5	52,200	5	600	16,980	11,810	23,810	541	117	(1) 10	332	16,230	3' 6 1/2"	15' 2"
8 x 18	XLP2-818-374	3,740	250	7.5	51,000	5	600	18,890	13,810	25,910	647	140	(1) 10	332	16,250	4' 3 3/4"	15' 11 1/4"
8 x 18	XLP2-818-379	3,790	252	15	67,650	5	600	15,070	9,810	21,790	435	94	(1) 10	332	18,250	2' 9 1/4"	14' 4 3/4"
8 x 18	XLP2-818-382	3,820	255	10	57,400	5	600	16,990	11,810	23,820	541	117	(1) 10	332	18,260	3' 6 1/2"	15' 2"
8 x 18	XLP2-818-401	4,010	267	10	56,100	5	600	18,990	13,810	25,920	647	140	(1) 10	332	20,350	4' 3 3/4"	15' 11 1/4"
8 x 18	XLP2-818-405	4,050	270	20	74,500	5	600	15,090	9,810	21,810	435	94	(1) 10	332	20,360	2' 9 1/4"	14' 4 3/4"
8 x 18	XLP2-818-421	4,210	281	15	65,700	5	600	17,070	11,810	23,900	541	117	(1) 10	332	18,340	3' 6 1/2"	15' 2"
8 x 18	XLP2-818-443	4,430	295	15	64,200	5	600	19,070	13,810	26,000	647	140	(1) 10	332	20,440	4' 3 3/4"	15' 11 1/4"
8 x 18	XLP2-818-451	4,510	301	20	72,300	5	600	17,090	11,810	23,920	541	117	(1) 10	332	18,360	3' 6 1/2"	15' 2"
8 x 18	XLP2-818-474	4,740	316	20	70,650	5	600	19,090	13,810	26,020	647	140	(1) 10	332	20,460	4' 3 3/4"	15' 11 1/4"
10 x 12	XLP2-1012-282	2,820	188	6	50,400	5	500	12,240	8,360	18,310	369	40	(1) 8	305	13,710	2' 9 1/4"	13' 9 1/2"
10 x 12	XLP2-1012-319	3,190	213	10	59,800	5	500	12,270	8,360	18,340	369	40	(1) 8	305	13,740	2' 9 1/4"	13' 9 1/2"
10 x 12	XLP2-1012-320	3,200	213	6	46,700	5	500	13,920	10,040	20,080	458	50	(1) 8	305	13,800	3' 6 1/2"	14' 6 3/4"
10 x 12	XLP2-1012-324	3,240	216	6	43,800	5	500	15,600	11,720	21,850	546	59	(1) 8	305	15,480	4' 3 3/4"	15' 4"
10 x 12	XLP2-1012-343	3,430	228	6	40,100	5	500	16,570	12,690	22,880	608	131	(1) 8	305	17,250	4' 3 3/4"	15' 4"
10 x 12	XLP2-1012-352	3,520	235	15	68,500	5	500	12,330	8,360	18,400	369	40	(1) 8	305	18,280	2' 9 1/4"	13' 9 1/2"
10 x 12	XLP2-1012-362	3,620	241	10	55,400	5	500	13,950	10,040	20,110	458	50	(1) 8	305	15,510	3' 6 1/2"	14' 6 3/4"
10 x 12	XLP2-1012-367	3,670	245	10	51,900	5	500	15,630	11,720	21,880	546	59	(1) 8	305	17,280	4' 3 3/4"	15' 4"
10 x 12	XLP2-1012-369	3,690	246	6	42,100	5	500	18,410	14,530	24,820	707	153	(1) 8	305	20,220	5' 1"	16' 1 1/4"
10 x 12	XLP2-1012-387	3,870	258	10	47,600	5	500	16,600	12,690	22,910	608	131	(1) 8	305	18,310	4' 3 3/4"	15' 4"
10 x 12	XLP2-1012-399	3,990	266	15	63,400	5	500	14,010	10,040	20,170	458	50	(1) 8	305	15,570	3' 6 1/2"	14' 6 3/4"
10 x 12	XLP2-1012-404	4,040	270	15	59,400	5	500	15,690	11,720	21,940	546	59	(1) 8	305	17,340	4' 3 3/4"	15' 4"
10 x 12	XLP2-1012-418	4,180	279	10	49,900	5	500	18,440	14,530	24,850	707	153	(1) 8	305	20,250	5' 1"	16' 1 1/4"
10 x 12	XLP2-1012-427	4,270	284	15	54,500	5	500	16,660	12,690	22,970	608	131	(1) 8	305	18,370	4' 3 3/4"	15' 4"
10 x 12	XLP2-1012-428	4,280	285	20	69,800	5	500	14,030	10,040	20,190	458	50	(1) 8	305	15,590	3' 6 1/2"	14' 6 3/4"
10 x 12	XLP2-1012-433	4,330	289	20	65,400	5	500	15,710	11,720	21,960	546	59	(1) 8	305	17,360	4' 3 3/4"	15' 4"
10 x 12	XLP2-1012-456	4,560	304	20	60,000	5	500	16,680	12,690	22,990	608	131	(1) 8	305	18,390	4' 3 3/4"	15' 4"
10 x 12	XLP2-1012-457	4,570	305	25	70,500	5	500	15,850	11,720	22,100	546	59	(1) 8	305	17,500	4' 3 3/4"	15' 4"
10 x 12	XLP2-1012-461	4,610	307	15	57,100	5	500	18,500	14,530	24,910	707	153	(1) 8	305	20,310	5' 1"	16' 1 1/4"
10 x 12	XLP2-1012-482	4,820	321	25	64,600	5	500	16,820	12,690	23,130	608	131	(1) 8	305	18,530	4' 3 3/4"	15' 4"
10 x 12	XLP2-1012-494	4,940	329	20	62,800	5	500	18,520	14,530	24,930	707	153	(1) 8	305	20,330	5' 1"	16' 1 1/4"
10 x 12	XLP2-1012-503	5,030	335	30	68,600	5	500	16,820	12,690	23,130	608	131	(1) 8	305	18,540	4' 3 3/4"	15' 4"
10 x 12	XLP2-1012-521	5,210	348	25	67,700	5	500	18,660	14,530	25,070	707	153	(1) 8	305	20,470	5' 1"	16' 1 1/4"
10 x 12	XLP2-1012-545	5,450	363	30	71,900	5	500	18,660	14,530	25,070	707	153	(1) 8	305	20,480	5' 1"	16' 1 1/4"

NOTES:

- Model number denotes condenser box size followed by nominal condenser capacity in MBH ÷ 10 at 96.3°F condensing and 78°F wet bulb; for example: XLP2-512-130 has 5' x 12' box size and 1,300 MBH.
- MBH at 96.3°F condensing and 78°F wet bulb with R-717.
- R-717 tons are at a 96.3°F condensing temperature, a 20°F suction temperature, and a 78°F entering wet-bulb temperature.
- Operating weight shown is based on total unit weight, weight of refrigerant operating charge, and cold water basin filled to the overflow level.
- Unless otherwise noted, the coil section is the heaviest section.
- Standard refrigerant connection size is 4" BFW (inlet and outlet).
- Refrigerant charge listed is R-717 operating charge. To determine operating charge for R-134a, multiply by 1.98.

NOTE: Do not use for construction. Refer to factory certified dimensions. This handbook includes data current at the time of publication, which should be reconfirmed at the time of purchase. Up-to-date engineering data, free product selection software and more can be found at www.johnsoncontrols.com.

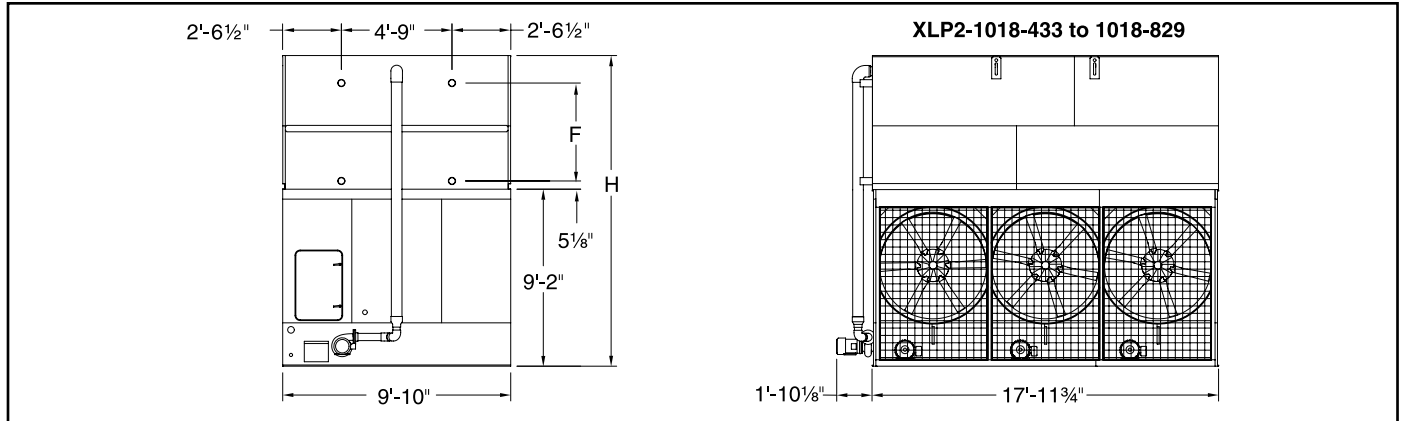

Nom Box Size	Model Number ¹	MBH ²	Evap Tons ³	Fan Motor (HP)	Airflow Rate (CFM)	Pump Motor (HP)	Spray Flow Rate (GPM)	Approximate Weights (lb)			R-717 Oper Charge (lb) ⁷	Internal Coil Volume (ft ³)	Remote Sump Bottom Connection			F	H
								Ship Weight (lb)	Heaviest Section (lb) ⁵	Oper Weight (lb) ⁴			Drain Size (in.)	Vol Req (gal.)	Approx. Oper Weight (lb)		
10 x 18	XLP2-1018-433	4,330	289	9	85,600	7.5	760	17,740	12,010	26,940	551	119	(1) 10	418	19,920	2' 9 1/4"	13' 9 1/2"
10 x 18	XLP2-1018-480	4,800	320	9	73,500	7.5	760	20,230	14,500	29,570	684	148	(1) 10	418	22,550	3' 6 1/2"	14' 6 3/4"
10 x 18	XLP2-1018-489	4,890	326	15	87,700	7.5	760	17,770	12,010	26,970	551	119	(1) 10	418	19,950	2' 9 1/4"	13' 9 1/2"
10 x 18	XLP2-1018-500	5,000	333	9	69,000	7.5	760	22,730	17,000	32,200	818	177	(1) 10	418	25,180	4' 3 3/4"	15' 4"
10 x 18	XLP2-1018-519	5,190	346	9	60,300	7.5	760	24,240	18,510	33,800	911	197	(1) 10	418	26,780	4' 3 3/4"	15' 4"
10 x 18	XLP2-1018-539	5,390	360	22.5	100,400	7.5	760	17,870	12,010	27,070	551	119	(1) 10	418	20,050	2' 9 1/4"	13' 9 1/2"
10 x 18	XLP2-1018-543	5,430	362	15	87,200	7.5	760	20,260	14,500	29,600	684	148	(1) 10	418	22,580	3' 6 1/2"	14' 6 3/4"
10 x 18	XLP2-1018-564	5,640	376	9	63,100	7.5	760	26,990	21,260	36,700	1,061	229	(1) 10	418	29,680	5' 1"	16' 1 1/4"
10 x 18	XLP2-1018-565	5,650	377	15	81,800	7.5	760	22,760	17,000	32,230	818	177	(1) 10	418	25,210	4' 3 3/4"	15' 4"
10 x 18	XLP2-1018-578	5,780	385	30	110,500	7.5	760	17,900	12,010	27,100	551	119	(1) 10	418	20,080	2' 9 1/4"	13' 9 1/2"
10 x 18	XLP2-1018-587	5,870	392	15	71,500	7.5	760	24,270	18,510	33,830	911	197	(1) 10	418	26,810	4' 3 3/4"	15' 4"
10 x 18	XLP2-1018-596	5,960	397	22.5	95,700	7.5	760	20,360	14,500	29,700	684	148	(1) 10	418	22,680	3' 6 1/2"	14' 6 3/4"
10 x 18	XLP2-1018-622	6,220	415	22.5	93,600	7.5	760	22,860	17,000	32,330	818	177	(1) 10	418	25,310	4' 3 3/4"	15' 4"
10 x 18	XLP2-1018-637	6,370	425	15	74,800	7.5	760	27,020	21,260	36,730	1,061	229	(1) 10	418	29,710	5' 1"	16' 1 1/4"
10 x 18	XLP2-1018-638	6,380	426	30	105,300	7.5	760	20,390	14,500	29,730	684	148	(1) 10	418	22,710	3' 6 1/2"	14' 6 3/4"
10 x 18	XLP2-1018-648	6,480	432	22.5	81,800	7.5	760	24,370	18,510	33,930	911	197	(1) 10	418	26,910	4' 3 3/4"	15' 4"
10 x 18	XLP2-1018-660	6,600	440	30	100,500	7.5	760	22,890	17,000	32,360	818	177	(1) 10	418	25,340	4' 3 3/4"	15' 4"
10 x 18	XLP2-1018-695	6,950	463	30	90,000	7.5	760	24,400	18,510	33,960	911	197	(1) 10	418	26,940	4' 3 3/4"	15' 4"
10 x 18	XLP2-1018-696	6,960	464	37.5	108,300	7.5	760	23,100	17,000	32,570	818	177	(1) 10	418	25,550	4' 3 3/4"	15' 4"
10 x 18	XLP2-1018-702	7,020	468	22.5	85,600	7.5	760	27,120	21,260	36,830	1,061	229	(1) 10	418	29,810	5' 1"	16' 1 1/4"
10 x 18	XLP2-1018-733	7,330	489	37.5	97,000	7.5	760	24,610	18,510	24,170	911	197	(1) 10	418	27,150	4' 3 3/4"	15' 4"
10 x 18	XLP2-1018-752	7,520	501	30	94,200	7.5	760	27,150	21,260	36,860	1,061	229	(1) 10	418	29,840	5' 1"	16' 1 1/4"
10 x 18	XLP2-1018-793	7,930	529	37.5	101,600	7.5	760	27,360	21,260	37,070	1,061	229	(1) 10	418	30,060	5' 1"	16' 1 1/4"
10 x 18	XLP2-1018-829	8,290	553	45	107,900	7.5	760	27,360	21,260	37,070	1,061	229	(1) 10	418	30,060	5' 1"	16' 1 1/4"

NOTES:

- Model number denotes condenser box size followed by nominal condenser capacity in MBH ÷ 10 at 96.3°F condensing and 78°F wet bulb; for example: XLP2-512-130 has 5' x 12' box size and 1,300 MBH.
- MBH at 96.3°F condensing and 78°F wet bulb with R-717.
- R-717 tons are at a 96.3°F condensing temperature, a 20°F suction temperature, and a 78°F entering wet-bulb temperature.
- Operating weight shown is based on total unit weight, weight of refrigerant operating charge, and cold water basin filled to the overflow level.
- Unless otherwise noted, the coil section is the heaviest section.
- Standard refrigerant connection size is 4" BFW (inlet and outlet).
- Refrigerant charge listed is R-717 operating charge. To determine operating charge for R-134a, multiply by 1.98.

NOTE: Do not use for construction. Refer to factory certified dimensions. This handbook includes data current at the time of publication, which should be reconfirmed at the time of purchase. Up-to-date engineering data, free product selection software and more can be found at www.johnsoncontrols.com.

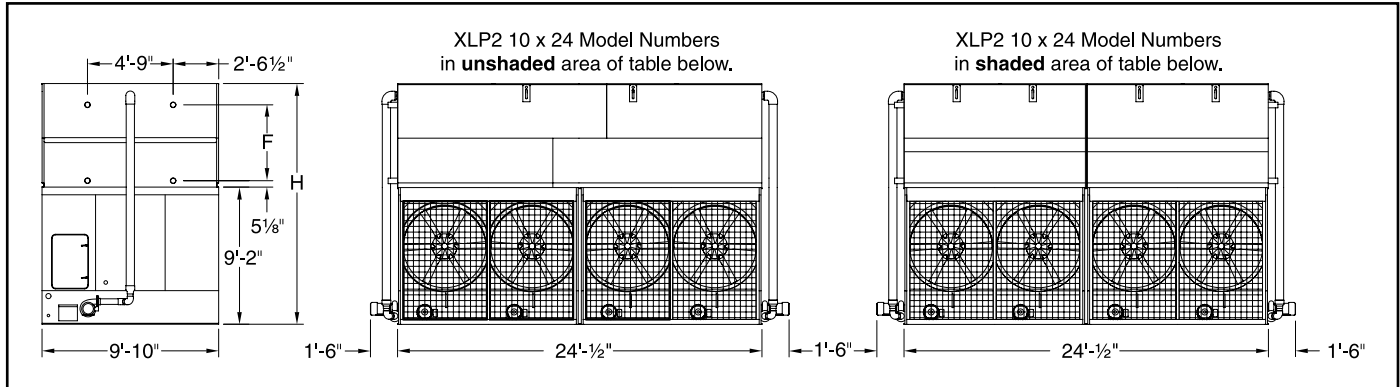

Nom Box Size	Model Number ¹	MBH ²	Evap Tons ³	Fan Motor (HP)	Airflow Rate (CFM)	Pump Motor (HP)	Spray Flow Rate (GPM)	Approximate Weights (lb)			R-717 Oper Charge (lb) ⁷	Internal Coil Volume (ft ³)	Remote Sump Bottom Connection			F	H
								Ship Weight (lb)	Heaviest Section (lb) ⁵	Oper Weight (lb) ⁴			Drain Size (in.)	Vol Req (gal.)	Approx. Oper Weight (lb)		
10 x 24	XLP2-1024-660	6,600	440	12	93,400	(2) 5	1020	27,200	19,440	39,520	912	197	(1) 12	481	35,410	3' 6 1/2"	14' 6 3/4"
10 x 24	XLP2-1024-668	6,680	446	12	87,600	(2) 5	1020	30,510	22,750	43,010	1,091	236	(1) 12	481	38,900	4' 3 3/4"	15' 4"
10 x 24	XLP2-1024-706	7,060	470	12	80,200	(2) 5	1020	32,750	24,810	45,190	1,216	263	(1) 12	481	41,070	4' 3 3/4"	15' 4"
10 x 24	XLP2-1024-745	7,450	497	20	110,800	(2) 5	1020	27,250	19,440	39,570	912	197	(1) 12	481	35,450	3' 6 1/2"	14' 6 3/4"
10 x 24	XLP2-1024-756	7,560	504	20	103,800	(2) 5	1020	30,560	22,750	43,060	1,091	236	(1) 12	481	38,940	4' 3 3/4"	15' 4"
10 x 24	XLP2-1024-799	7,990	532	20	95,200	(2) 5	1020	32,620	24,810	45,240	1,216	263	(1) 12	481	41,110	4' 3 3/4"	15' 4"
10 x 24	XLP2-1024-822	8,220	548	30	126,800	(2) 5	1020	27,370	19,440	39,690	912	197	(1) 12	481	35,580	3' 6 1/2"	14' 6 3/4"
10 x 24	XLP2-1024-833	8,330	555	30	118,800	(2) 5	1020	30,680	22,750	43,180	1,091	236	(1) 12	481	39,070	4' 3 3/4"	15' 4"
10 x 24	XLP2-1024-879	8,790	586	30	109,000	(2) 5	1020	32,740	24,810	45,360	1,216	263	(1) 12	481	41,240	4' 3 3/4"	15' 4"
10 x 24	XLP2-1024-881	8,810	587	40	139,600	(2) 5	1020	27,420	19,440	39,740	912	197	(1) 12	481	35,630	3' 6 1/2"	14' 6 3/4"
10 x 24	XLP2-1024-892	8,920	595	40	130,800	(2) 5	1020	30,730	22,750	43,230	1,091	236	(1) 12	481	39,120	4' 3 3/4"	15' 4"
10 x 24	XLP2-1024-940	9,400	627	40	120,000	(2) 5	1020	32,790	24,810	45,410	1,216	263	(1) 12	481	41,290	4' 3 3/4"	15' 4"
10 x 24	XLP2-1024-564	5,640	376	12	100,800	(2) 5	1020	24,580	8,410	36,730	739	80	(1) 12	481	32,420	2' 9 1/4"	13' 9 1/2"
10 x 24	XLP2-1024-638	6,380	426	20	119,600	(2) 5	1020	24,630	8,410	36,780	739	80	(1) 12	481	32,460	2' 9 1/4"	13' 9 1/2"
10 x 24	XLP2-1024-640	6,400	427	12	93,400	(2) 5	1020	27,940	10,090	40,260	916	99	(1) 12	481	35,950	3' 6 1/2"	14' 6 3/4"
10 x 24	XLP2-1024-649	6,490	433	12	87,600	(2) 5	1020	31,300	11,770	43,800	1,093	118	(1) 12	481	39,490	4' 3 3/4"	15' 4"
10 x 24	XLP2-1024-685	6,850	457	12	80,200	(2) 5	1020	33,240	12,740	45,860	1,216	263	(1) 12	481	41,540	4' 3 3/4"	15' 4"
10 x 24	XLP2-1024-704	7,040	470	30	137,000	(2) 5	1020	24,750	8,410	36,900	739	80	(1) 12	481	32,590	2' 9 1/4"	13' 9 1/2"
10 x 24	XLP2-1024-723	7,230	482	20	110,800	(2) 5	1020	27,990	10,090	40,310	916	99	(1) 12	481	35,990	3' 6 1/2"	14' 6 3/4"
10 x 24	XLP2-1024-734	7,340	489	20	103,800	(2) 5	1020	31,350	11,770	43,850	1,093	118	(1) 12	481	39,530	4' 3 3/4"	15' 4"
10 x 24	XLP2-1024-738	7,380	492	12	84,200	(2) 5	1020	36,920	14,580	49,740	1,414	305	(1) 12	481	45,420	5' 1"	16' 1 1/4"
10 x 24	XLP2-1024-775	7,750	516	20	95,200	(2) 5	1020	33,290	12,740	45,910	1,216	263	(1) 12	481	41,580	4' 3 3/4"	15' 4"
10 x 24	XLP2-1024-798	7,980	532	30	126,800	(2) 5	1020	28,110	10,090	40,430	916	99	(1) 12	481	36,120	3' 6 1/2"	14' 6 3/4"
10 x 24	XLP2-1024-809	8,090	539	30	118,800	(2) 5	1020	31,470	11,770	43,970	1,093	118	(1) 12	481	39,660	4' 3 3/4"	15' 4"
10 x 24	XLP2-1024-836	8,360	557	20	99,800	(2) 5	1020	36,970	14,580	49,790	1,414	305	(1) 12	481	45,460	5' 1"	16' 1 1/4"
10 x 24	XLP2-1024-853	8,530	569	30	109,000	(2) 5	1020	33,410	12,740	46,030	1,216	263	(1) 12	481	41,710	4' 3 3/4"	15' 4"
10 x 24	XLP2-1024-855	8,550	570	40	139,600	(2) 5	1020	28,160	10,090	40,480	916	99	(1) 12	481	36,170	3' 6 1/2"	14' 6 3/4"
10 x 24	XLP2-1024-866	8,660	577	40	130,800	(2) 5	1020	31,520	11,770	44,020	1,093	118	(1) 12	481	39,710	4' 3 3/4"	15' 4"
10 x 24	XLP2-1024-913	9,130	609	40	120,000	(2) 5	1020	33,460	12,740	46,080	1,216	263	(1) 12	481	41,760	4' 3 3/4"	15' 4"
10 x 24	XLP2-1024-915	9,150	610	50	141,000	(2) 5	1020	31,800	11,770	44,300	1,093	118	(1) 12	481	39,990	4' 3 3/4"	15' 4"
10 x 24	XLP2-1024-921	9,210	614	30	114,200	(2) 5	1020	37,090	14,580	49,910	1,414	305	(1) 12	481	45,590	5' 1"	16' 1 1/4"
10 x 24	XLP2-1024-964	9,640	643	50	129,200	(2) 5	1020	33,740	12,740	46,360	1,216	263	(1) 12	481	42,040	4' 3 3/4"	15' 4"
10 x 24	XLP2-1024-987	9,870	658	40	125,600	(2) 5	1020	37,140	14,580	49,960	1,414	305	(1) 12	481	45,640	5' 1"	16' 1 1/4"
10 x 24	XLP2-1024-1006	10,060	671	60	137,200	(2) 5	1020	33,740	12,740	46,360	1,216	263	(1) 12	481	42,040	4' 3 3/4"	15' 4"
10 x 24	XLP2-1024-1043	10,430	695	50	135,400	(2) 5	1020	37,420	14,580	50,240	1,414	305	(1) 12	481	45,920	5' 1"	16' 1 1/4"
10 x 24	XLP2-1024-1089	10,890	726	60	143,800	(2) 5	1020	37,420	14,580	50,240	1,414	305	(1) 12	481	45,920	5' 1"	16' 1 1/4"

NOTES:

- Model number denotes condenser box size followed by nominal condenser capacity in MBH ÷ 10 at 96.3°F condensing and 78°F wet bulb; for example: XLP2-512-130 has 5' x 12' box size and 1,300 MBH.
- MBH at 96.3°F condensing and 78°F wet bulb with R-717.
- R-717 tons are at a 96.3°F condensing temperature, a 20°F suction temperature, and a 78°F entering wet-bulb temperature.
- Operating weight shown is based on total unit weight, weight of refrigerant operating charge, and cold water basin filled to the overflow level.
- Unless otherwise noted, the coil section is the heaviest section.
- Standard refrigerant connection size is 4" BFW (inlet and outlet).
- Refrigerant charge listed is R-717 operating charge. To determine operating charge for R-134a, multiply by 1.98.

NOTE: Do not use for construction. Refer to factory certified dimensions. This handbook includes data current at the time of publication, which should be confirmed at the time of purchase. Up-to-date engineering data, free product selection software and more can be found at www.johnsoncontrols.com.

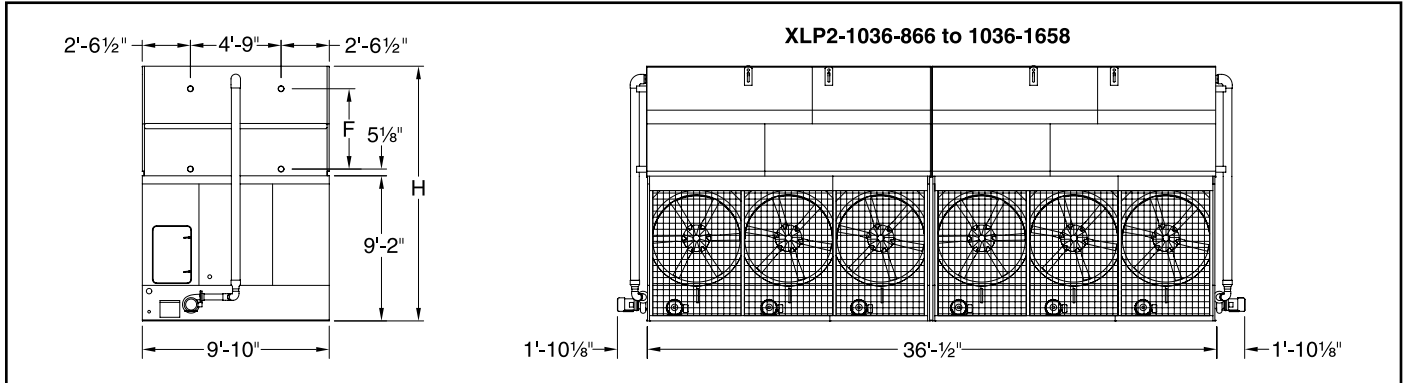

Nom Box Size	Model Number ¹	MBH ²	Evap Tons ³	Fan Motor (HP)	Airflow Rate (CFM)	Pump Motor (HP)	Spray Flow Rate (GPM)	Approximate Weights (lb)			R-717 Oper Charge (lb) ⁷	Internal Coil Volume (ft ³)	Remote Sump Bottom Connection			F	H
								Ship Weight (lb)	Heaviest Section (lb) ⁵	Oper Weight (lb) ⁴			Drain Size (in.)	Vol Req (gal.)	Approx. Oper Weight (lb)		
10 x 36	XLP2-1036-866	8,660	577	18	171,200	(2) 7.5	1540	35,640	12,100	54,040	1,102	238	(1) 14	835	50,110	2' 9 1/2"	13' 9 1/2"
10 x 36	XLP2-1036-960	9,600	640	18	147,000	(2) 7.5	1540	40,630	14,590	59,300	1,369	296	(1) 14	835	55,360	3' 6 1/2"	14' 6 3/4"
10 x 36	XLP2-1036-979	9,790	653	30	175,400	(2) 7.5	1540	35,710	12,100	54,110	1,102	238	(1) 14	835	50,180	2' 9 1/2"	13' 9 1/2"
10 x 36	XLP2-1036-1000	10,000	667	18	138,000	(2) 7.5	1540	45,620	17,090	64,560	1,637	354	(1) 14	835	60,610	4' 3 3/4"	15' 4"
10 x 36	XLP2-1036-1038	10,380	692	18	120,600	(2) 7.5	1540	48,640	18,600	67,770	1,823	394	(1) 14	835	63,820	4' 3 3/4"	15' 4"
10 x 36	XLP2-1036-1079	10,790	719	45	200,800	(2) 7.5	1540	35,900	12,100	54,300	1,102	238	(1) 14	835	50,370	2' 9 1/2"	13' 9 1/2"
10 x 36	XLP2-1036-1085	10,850	723	30	174,400	(2) 7.5	1540	40,700	14,590	59,370	1,369	296	(1) 14	835	55,430	3' 6 1/2"	14' 6 3/4"
10 x 36	XLP2-1036-1128	11,280	752	18	126,200	(2) 7.5	1540	54,130	21,340	73,550	2,122	458	(1) 14	835	69,600	5' 1"	16' 1 1/4"
10 x 36	XLP2-1036-1130	11,300	753	30	163,600	(2) 7.5	1540	45,690	17,090	64,630	1,637	354	(1) 14	835	60,680	4' 3 3/4"	15' 4"
10 x 36	XLP2-1036-1155	11,550	770	60	221,000	(2) 7.5	1540	35,970	12,100	54,370	1,102	238	(1) 14	835	50,440	2' 9 1/2"	13' 9 1/2"
10 x 36	XLP2-1036-1175	11,750	783	30	143,000	(2) 7.5	1540	48,710	18,600	67,840	1,823	394	(1) 14	835	63,890	4' 3 3/4"	15' 4"
10 x 36	XLP2-1036-1192	11,920	794	45	191,400	(2) 7.5	1540	40,890	14,590	59,560	1,369	296	(1) 14	835	55,620	3' 6 1/2"	14' 6 3/4"
10 x 36	XLP2-1036-1245	12,450	830	45	187,200	(2) 7.5	1540	45,880	17,090	64,820	1,637	354	(1) 14	835	60,870	4' 3 3/4"	15' 4"
10 x 36	XLP2-1036-1275	12,750	850	30	149,600	(2) 7.5	1540	54,200	21,340	73,620	2,122	458	(1) 14	835	69,670	5' 1"	16' 1 1/4"
10 x 36	XLP2-1036-1277	12,770	851	60	210,600	(2) 7.5	1540	40,960	14,590	59,630	1,369	296	(1) 14	835	55,690	3' 6 1/2"	14' 6 3/4"
10 x 36	XLP2-1036-1296	12,960	864	45	163,600	(2) 7.5	1540	48,900	18,600	68,030	1,823	394	(1) 14	835	64,080	4' 3 3/4"	15' 4"
10 x 36	XLP2-1036-1319	13,190	879	60	201,000	(2) 7.5	1540	45,950	17,090	64,890	1,637	354	(1) 14	835	60,940	4' 3 3/4"	15' 4"
10 x 36	XLP2-1036-1389	13,890	926	60	180,000	(2) 7.5	1540	48,970	18,600	68,100	1,823	394	(1) 14	835	64,150	4' 3 3/4"	15' 4"
10 x 36	XLP2-1036-1392	13,920	928	75	216,600	(2) 7.5	1540	46,370	17,090	65,310	1,637	354	(1) 14	835	61,360	4' 3 3/4"	15' 4"
10 x 36	XLP2-1036-1404	14,040	936	45	171,200	(2) 7.5	1540	54,390	21,340	73,810	2,122	458	(1) 14	835	69,860	5' 1"	16' 1 1/4"
10 x 36	XLP2-1036-1466	14,660	977	75	194,000	(2) 7.5	1540	49,390	18,600	68,520	1,823	394	(1) 14	835	64,570	4' 3 3/4"	15' 4"
10 x 36	XLP2-1036-1504	15,040	1003	60	188,400	(2) 7.5	1540	54,460	21,340	73,880	2,122	458	(1) 14	835	69,930	5' 1"	16' 1 1/4"
10 x 36	XLP2-1036-1587	15,870	1058	75	203,000	(2) 7.5	1540	54,880	21,340	74,300	2,122	458	(1) 14	835	70,350	5' 1"	16' 1 1/4"
10 x 36	XLP2-1036-1658	16,580	1105	90	215,800	(2) 7.5	1540	54,880	21,340	74,300	2,122	458	(1) 14	835	70,350	5' 1"	16' 1 1/4"

NOTES:

- Model number denotes condenser box size followed by nominal condenser capacity in MBH ÷ 10 at 96.3°F condensing and 78°F wet bulb; for example: XLP2-512-130 has 5' x 12' box size and 1,300 MBH.
- MBH at 96.3°F condensing and 78°F wet bulb with R-717.
- R-717 tons are at a 96.3°F condensing temperature, a 20°F suction temperature, and a 78°F entering wet-bulb temperature.
- Operating weight shown is based on total unit weight, weight of refrigerant operating charge, and cold water basin filled to the overflow level.
- Unless otherwise noted, the coil section is the heaviest section.
- Standard refrigerant connection size is 4" BFW (inlet and outlet).
- Refrigerant charge listed is R-717 operating charge. To determine operating charge for R-134a, multiply by 1.98.

NOTE: Do not use for construction. Refer to factory certified dimensions. This handbook includes data current at the time of publication, which should be reconfirmed at the time of purchase. Up-to-date engineering data, free product selection software and more can be found at www.johnsoncontrols.com.

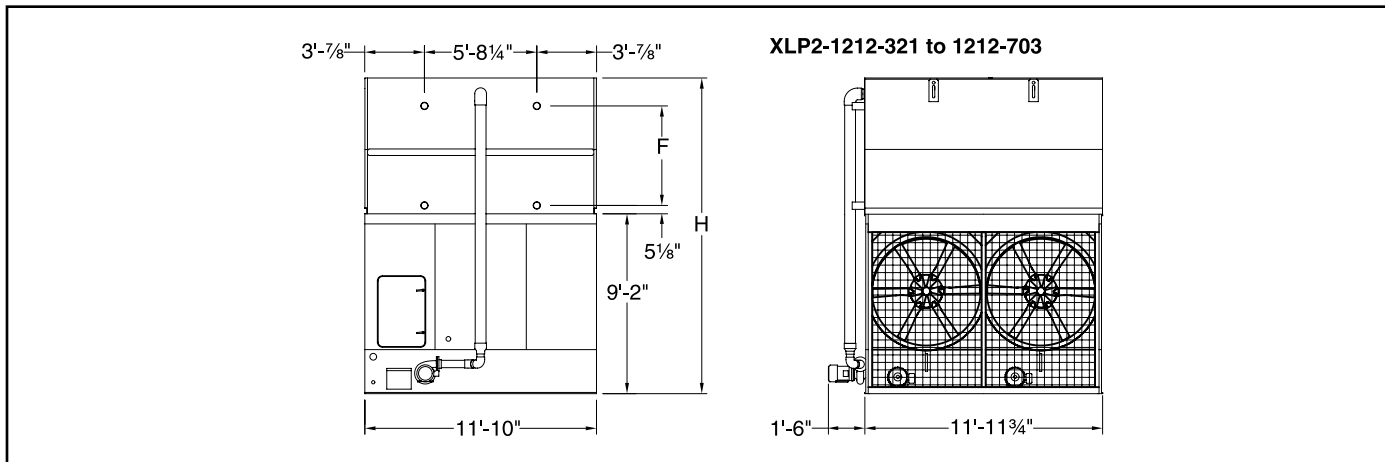

Nom Box Size	Model Number ¹	MBH ²	Evap Tons ³	Fan Motor (HP)	Airflow Rate (CFM)	Pump Motor (HP)	Spray Flow Rate (GPM)	Approximate Weights (lb)			R-717 Oper Charge (lb) ⁷	Internal Coil Volume (ft ³)	Remote Sump Bottom Connection			F	H
								Ship Weight (lb)	Heaviest Section (lb) ⁵	Oper Weight (lb) ⁴			Drain Size (in.)	Vol Req (gal.)	Approx. Oper Weight (lb)		
12 x 12	XLP2-1212-321	3,210	214	6	50,400	5	610	13,900	9,880	21,620	447	97	(1) 8	506	16,900	2' 9 1/4"	13' 9 1/2"
12 x 12	XLP2-1212-359	3,590	239	6	50,400	5	610	15,850	11,890	23,680	554	120	(1) 8	506	18,960	3' 6 1/2"	14' 6 3/4"
12 x 12	XLP2-1212-364	3,640	243	10	59,750	5	610	13,920	9,880	21,640	447	97	(1) 8	506	16,920	2' 9 1/4"	13' 9 1/2"
12 x 12	XLP2-1212-376	3,760	250	6	47,800	5	610	17,870	13,910	25,800	661	143	(1) 8	506	21,080	4' 3 3/4"	15' 4"
12 x 12	XLP2-1212-390	3,900	260	6	47,700	5	610	19,110	15,150	27,120	734	159	(1) 8	506	22,400	4' 3 3/4"	15' 4"
12 x 12	XLP2-1212-401	4,010	267	15	68,400	5	610	13,880	9,880	21,600	447	97	(1) 8	506	16,880	2' 9 1/4"	13' 9 1/2"
12 x 12	XLP2-1212-405	4,050	270	10	59,800	5	610	15,860	11,890	23,690	554	120	(1) 8	506	18,970	3' 6 1/2"	14' 6 3/4"
12 x 12	XLP2-1212-424	4,240	283	10	56,700	5	610	17,880	13,910	25,810	661	143	(1) 8	506	21,090	4' 3 3/4"	15' 4"
12 x 12	XLP2-1212-427	4,270	284	6	45,000	5	610	21,230	17,270	29,360	854	184	(1) 8	506	24,640	5' 1"	16' 1 1/4"
12 x 12	XLP2-1212-430	4,300	287	20	75,300	5	610	13,900	9,880	21,620	447	97	(1) 8	506	16,900	2' 9 1/4"	13' 9 1/2"
12 x 12	XLP2-1212-442	4,420	294	10	56,500	5	610	19,120	15,150	27,130	734	159	(1) 8	506	22,410	4' 3 3/4"	15' 4"
12 x 12	XLP2-1212-447	4,470	298	15	68,400	5	610	15,890	11,890	23,720	554	120	(1) 8	506	19,000	3' 6 1/2"	14' 6 3/4"
12 x 12	XLP2-1212-453	4,530	302	25	81,100	5	610	13,970	9,880	21,690	447	97	(1) 8	506	16,970	2' 9 1/4"	13' 9 1/2"
12 x 12	XLP2-1212-468	4,680	312	15	64,900	5	610	17,910	13,910	25,840	661	143	(1) 8	506	21,120	4' 3 3/4"	15' 4"
12 x 12	XLP2-1212-480	4,800	320	20	73,100	5	610	15,910	11,890	23,740	554	120	(1) 8	506	19,020	3' 6 1/2"	14' 6 3/4"
12 x 12	XLP2-1212-483	4,830	322	10	53,400	5	610	21,240	17,270	29,370	854	184	(1) 8	506	24,650	5' 1"	16' 1 1/4"
12 x 12	XLP2-1212-487	4,870	325	15	64,700	5	610	19,150	15,150	27,160	734	159	(1) 8	506	22,440	4' 3 3/4"	15' 4"
12 x 12	XLP2-1212-501	5,010	334	20	71,400	5	610	17,930	13,910	25,860	661	143	(1) 8	506	21,140	4' 3 3/4"	15' 4"
12 x 12	XLP2-1212-506	5,060	338	25	78,700	5	610	15,980	11,890	23,810	554	120	(1) 8	506	19,090	3' 6 1/2"	14' 6 3/4"
12 x 12	XLP2-1212-522	5,220	348	20	71,200	5	610	19,170	15,150	27,180	734	159	(1) 8	506	22,460	4' 3 3/4"	15' 4"
12 x 12	XLP2-1212-523	5,230	348	25	76,950	5	610	18,000	13,910	25,930	661	143	(1) 8	506	21,210	4' 3 3/4"	15' 4"
12 x 12	XLP2-1212-533	5,330	355	15	61,100	5	610	21,270	17,270	29,400	854	184	(1) 8	506	24,680	5' 1"	16' 1 1/4"
12 x 12	XLP2-1212-546	5,460	364	30	81,750	5	610	18,000	13,910	25,930	661	143	(1) 8	506	21,210	4' 3 3/4"	15' 4"
12 x 12	XLP2-1212-551	5,510	367	25	76,700	5	610	19,240	15,150	27,250	734	159	(1) 8	506	22,530	4' 3 3/4"	15' 4"
12 x 12	XLP2-1212-571	5,710	381	20	67,300	5	610	21,290	17,270	29,420	854	184	(1) 8	506	24,700	5' 1"	16' 1 1/4"
12 x 12	XLP2-1212-576	5,760	384	30	81,500	5	610	19,240	15,150	27,250	734	159	(1) 8	506	22,530	4' 3 3/4"	15' 4"
12 x 12	XLP2-1212-597	5,970	398	25	72,500	5	610	21,360	17,270	29,490	854	184	(1) 8	506	24,770	5' 1"	16' 1 1/4"
12 x 12	XLP2-1212-617	6,170	411	40	89,700	5	610	19,480	15,150	27,490	734	159	(1) 8	506	22,770	4' 3 3/4"	15' 4"
12 x 12	XLP2-1212-622	6,220	415	30	77,040	5	610	21,360	17,270	29,490	854	184	(1) 8	506	24,770	5' 1"	16' 1 1/4"
12 x 12	XLP2-1212-666	6,660	444	40	85,200	5	610	21,460	17,270	29,590	854	184	(1) 8	506	24,870	5' 1"	16' 1 1/4"
12 x 12	XLP2-1212-703	7,030	469	50	91,800	5	610	21,600	17,270	29,730	854	184	(1) 8	506	25,010	5' 1"	16' 1 1/4"

NOTES:

- Model number denotes condenser box size followed by nominal condenser capacity in MBH ÷ 10 at 96.3°F condensing and 78°F wet bulb; for example: XLP2-512-130 has 5' x 12' box size and 1,300 MBH.
- MBH at 96.3°F condensing and 78°F wet bulb with R-717.
- R-717 tons are at a 96.3°F condensing temperature, a 20°F suction temperature, and a 78°F entering wet-bulb temperature.
- Operating weight shown is based on total unit weight, weight of refrigerant operating charge, and cold water basin filled to the overflow level.
- Unless otherwise noted, the coil section is the heaviest section.
- Standard refrigerant connection size is 4" BFW (inlet and outlet).
- Refrigerant charge listed is R-717 operating charge. To determine operating charge for R-134a, multiply by 1.98.

NOTE: Do not use for construction. Refer to factory certified dimensions. This handbook includes data current at the time of publication, which should be reconfirmed at the time of purchase. Up-to-date engineering data, free product selection software and more can be found at www.johnsoncontrols.com.

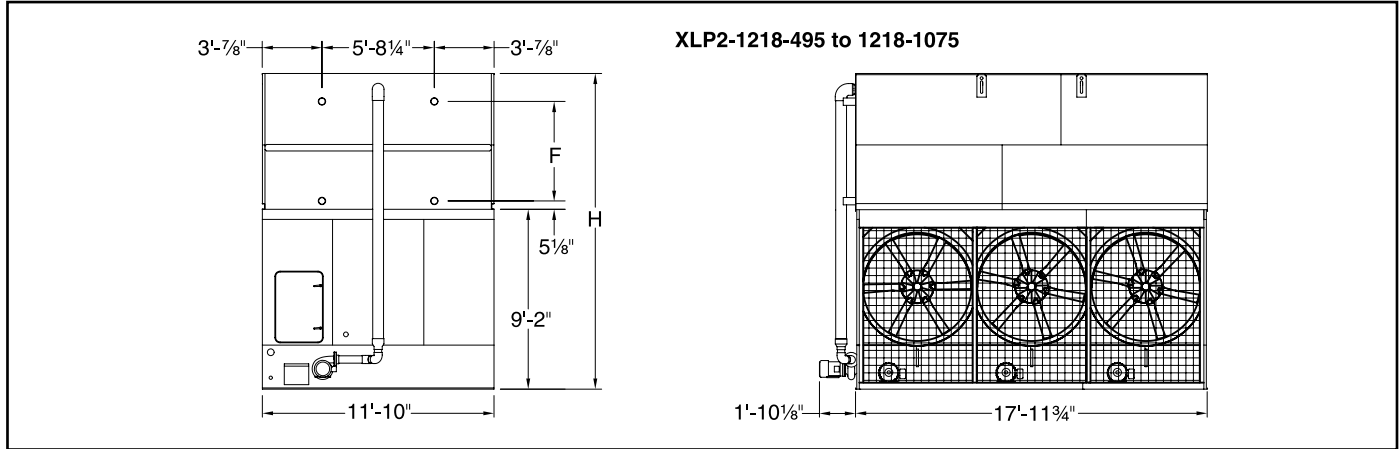

Nom Box Size	Model Number ¹	MBH ²	Evap Tons ³	Fan Motor (HP)	Airflow Rate (CFM)	Pump Motor (HP)	Spray Flow Rate (GPM)	Approximate Weights (lb)			R-717 Oper Charge (lb) ⁷	Internal Coil Volume (ft ³)	Remote Sump Bottom Connection			F	H
								Ship Weight (lb)	Heaviest Section (lb) ⁵	Oper Weight (lb) ⁴			Drain Size (in.)	Vol Req (gal.)	Approx. Oper Weight (lb)		
12 x 18	XLP2-1218-495	4,950	330	9	75,700	7.5	920	20,010	14,360	31,710	666	144	(1) 10	695	24,260	2' 9 1/4"	13' 9 1/2"
12 x 18	XLP2-1218-548	5,480	365	9	73,400	7.5	920	23,000	17,350	34,860	828	179	(1) 10	695	27,410	3' 6 1/2"	14' 6 3/4"
12 x 18	XLP2-1218-560	5,600	373	15	89,700	7.5	920	20,030	14,360	31,730	666	144	(1) 10	695	24,280	2' 9 1/4"	13' 9 1/2"
12 x 18	XLP2-1218-566	5,660	377	9	71,800	7.5	920	25,990	20,340	38,010	990	214	(1) 10	695	30,560	4' 3 3/4"	15' 4"
12 x 18	XLP2-1218-597	5,970	398	9	71,400	7.5	920	27,880	22,230	40,010	1,101	238	(1) 10	695	32,560	4' 3 3/4"	15' 4"
12 x 18	XLP2-1218-618	6,180	412	22.5	102,650	7.5	920	20,060	14,360	31,760	666	144	(1) 10	695	24,310	2' 9 1/4"	13' 9 1/2"
12 x 18	XLP2-1218-619	6,190	413	15	87,000	7.5	920	23,020	17,350	34,880	828	179	(1) 10	695	27,430	3' 6 1/2"	14' 6 3/4"
12 x 18	XLP2-1218-640	6,400	427	15	85,100	7.5	920	26,010	20,340	38,030	990	214	(1) 10	695	30,580	4' 3 3/4"	15' 4"
12 x 18	XLP2-1218-648	6,480	432	9	67,200	7.5	920	31,090	25,440	43,400	1,282	277	(1) 10	695	35,950	5' 1"	16' 1 1/4"
12 x 18	XLP2-1218-663	6,630	442	30	113,000	7.5	920	20,070	14,360	31,770	666	144	(1) 10	695	24,320	2' 9 1/4"	13' 9 1/2"
12 x 18	XLP2-1218-676	6,760	450	15	84,700	7.5	920	27,900	22,230	40,030	1,101	238	(1) 10	695	32,580	4' 3 3/4"	15' 4"
12 x 18	XLP2-1218-683	6,830	455	22.5	99,600	7.5	920	23,050	17,350	34,910	828	179	(1) 10	695	27,460	3' 6 1/2"	14' 6 3/4"
12 x 18	XLP2-1218-699	6,990	466	37.5	121,700	7.5	920	20,150	14,360	31,850	666	144	(1) 10	695	24,400	2' 9 1/4"	13' 9 1/2"
12 x 18	XLP2-1218-706	7,060	471	22.5	97,400	7.5	920	26,040	20,340	38,060	990	214	(1) 10	695	30,610	4' 3 3/4"	15' 4"
12 x 18	XLP2-1218-732	7,320	488	30	109,650	7.5	920	23,060	17,350	34,920	828	179	(1) 10	695	27,470	3' 6 1/2"	14' 6 3/4"
12 x 18	XLP2-1218-733	7,330	489	15	79,700	7.5	920	31,110	25,440	43,420	1,282	277	(1) 10	695	35,970	5' 1"	16' 1 1/4"
12 x 18	XLP2-1218-745	7,450	496	22.5	97,000	7.5	920	27,930	22,230	40,060	1,101	238	(1) 10	695	32,610	4' 3 3/4"	15' 4"
12 x 18	XLP2-1218-756	7,560	504	30	107,150	7.5	920	26,050	20,340	38,070	990	214	(1) 10	695	30,620	4' 3 3/4"	15' 4"
12 x 18	XLP2-1218-772	7,720	515	37.5	118,100	7.5	920	23,140	17,350	35,000	828	179	(1) 10	695	27,550	3' 6 1/2"	14' 6 3/4"
12 x 18	XLP2-1218-798	7,980	532	30	106,800	7.5	920	27,940	22,230	40,070	1,101	238	(1) 10	695	32,620	4' 3 3/4"	15' 4"
12 x 18	XLP2-1218-800	8,000	533	37.5	115,400	7.5	920	26,130	20,340	38,150	990	214	(1) 10	695	30,700	4' 3 3/4"	15' 4"
12 x 18	XLP2-1218-809	8,090	539	22.5	91,200	7.5	920	31,140	25,440	43,450	1,282	277	(1) 10	695	36,000	5' 1"	16' 1 1/4"
12 x 18	XLP2-1218-835	8,350	557	45	122,650	7.5	920	26,130	20,340	38,150	990	214	(1) 10	695	30,700	4' 3 3/4"	15' 4"
12 x 18	XLP2-1218-843	8,430	562	37.5	115,000	7.5	920	28,020	22,230	40,150	1,101	238	(1) 10	695	32,700	4' 3 3/4"	15' 4"
12 x 18	XLP2-1218-867	8,670	578	30	100,400	7.5	920	31,150	25,440	43,460	1,282	277	(1) 10	695	36,010	5' 1"	16' 1 1/4"
12 x 18	XLP2-1218-880	8,800	587	45	122,200	7.5	920	28,020	22,230	40,150	1,101	238	(1) 10	695	32,700	4' 3 3/4"	15' 4"
12 x 18	XLP2-1218-915	9,150	610	37.5	108,200	7.5	920	31,230	25,440	43,540	1,282	277	(1) 10	695	36,090	5' 1"	16' 1 1/4"
12 x 18	XLP2-1218-944	9,440	629	60	134,500	7.5	920	28,160	22,230	40,290	1,101	238	(1) 10	695	32,840	4' 3 3/4"	15' 4"
12 x 18	XLP2-1218-952	9,520	635	45	115,000	7.5	920	31,230	25,440	43,540	1,282	277	(1) 10	695	36,090	5' 1"	16' 1 1/4"
12 x 18	XLP2-1218-1018	10,180	679	60	126,080	7.5	920	31,370	25,440	43,680	1,282	277	(1) 10	695	36,230	5' 1"	16' 1 1/4"
12 x 18	XLP2-1218-1075	10,750	716	75	135,800	7.5	920	31,500	25,440	43,810	1,282	277	(1) 10	695	36,360	5' 1"	16' 1 1/4"

NOTES:

- Model number denotes condenser box size followed by nominal condenser capacity in MBH ÷ 10 at 96.3°F condensing and 78°F wet bulb; for example: XLP2-512-130 has 5' x 12' box size and 1,300 MBH.
- MBH at 96.3°F condensing and 78°F wet bulb with R-717.
- R-717 tons are at a 96.3°F condensing temperature, a 20°F suction temperature, and a 78°F entering wet-bulb temperature.
- Operating weight shown is based on total unit weight, weight of refrigerant operating charge, and cold water basin filled to the overflow level.
- Unless otherwise noted, the coil section is the heaviest section.
- Standard refrigerant connection size is 4" BFW (inlet and outlet).
- Refrigerant charge listed is R-717 operating charge. To determine operating charge for R-134a, multiply by 1.98.

NOTE: Do not use for construction. Refer to factory certified dimensions. This handbook includes data current at the time of publication, which should be reconfirmed at the time of purchase. Up-to-date engineering data, free product selection software and more can be found at www.johnsoncontrols.com.

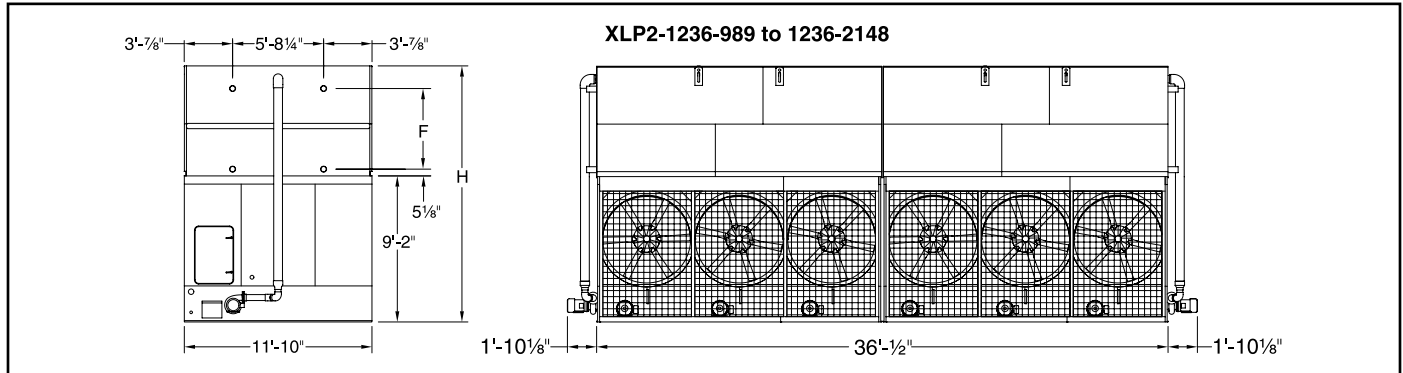

Nom Box Size	Model Number ¹	MBH ²	Evap Tons ³	Fan Motor (HP)	Airflow Rate (CFM)	Pump Motor (HP)	Spray Flow Rate (GPM)	Approximate Weights (lb)			R-717 Oper Charge (lb) ⁷	Internal Coil Volume (ft ³)	Remote Sump Bottom Connection			F	H
								Ship Weight (lb)	Heaviest Section (lb) ⁵	Oper Weight (lb) ⁴			Drain Size (in.)	Vol Req (gal.)	Approx. Oper Weight (lb)		
12 x 36	XLP2-1236-989	9,890	660	18	151,400	(2) 7.5	1860	40,190	14,480	63,590	1,332	288	(1) 14	1,428	49,410	2' 9 1/4"	13' 9 1/2"
12 x 36	XLP2-1236-1096	10,960	731	18	146,800	(2) 7.5	1860	46,160	17,460	69,880	1,656	358	(1) 14	1,428	55,700	3' 6 1/2"	14' 6 3/4"
12 x 36	XLP2-1236-1119	11,190	746	30	179,400	(2) 7.5	1860	40,210	14,480	63,610	1,332	288	(1) 14	1,428	49,430	2' 9 1/4"	13' 9 1/2"
12 x 36	XLP2-1236-1133	11,330	755	18	143,600	(2) 7.5	1860	52,130	20,450	76,170	1,980	428	(1) 14	1,428	62,000	4' 3 3/4"	15' 4"
12 x 36	XLP2-1236-1195	11,950	797	18	142,800	(2) 7.5	1860	55,920	22,340	80,190	2,203	476	(1) 14	1,428	66,020	4' 3 3/4"	15' 4"
12 x 36	XLP2-1236-1236	12,360	824	45	205,300	(2) 7.5	1860	40,250	14,480	63,650	1,332	288	(1) 14	1,428	49,470	2' 9 1/4"	13' 9 1/2"
12 x 36	XLP2-1236-1239	12,390	826	30	174,000	(2) 7.5	1860	46,180	17,460	69,900	1,656	358	(1) 14	1,428	55,720	3' 6 1/2"	14' 6 3/4"
12 x 36	XLP2-1236-1281	12,810	854	30	170,200	(2) 7.5	1860	52,150	20,450	76,190	1,980	428	(1) 14	1,428	62,020	4' 3 3/4"	15' 4"
12 x 36	XLP2-1236-1298	12,980	865	18	134,400	(2) 7.5	1860	62,330	25,550	86,960	2,564	554	(1) 14	1,428	72,790	5' 1"	16' 1 1/4"
12 x 36	XLP2-1236-1326	13,260	884	60	226,000	(2) 7.5	1860	40,270	14,480	63,670	1,332	288	(1) 14	1,428	49,490	2' 9 1/4"	13' 9 1/2"
12 x 36	XLP2-1236-1351	13,510	901	30	169,400	(2) 7.5	1860	55,940	22,340	80,210	2,203	476	(1) 14	1,428	66,040	4' 3 3/4"	15' 4"
12 x 36	XLP2-1236-1366	13,660	911	45	199,200	(2) 7.5	1860	46,220	17,460	69,940	1,656	358	(1) 14	1,428	55,760	3' 6 1/2"	14' 6 3/4"
12 x 36	XLP2-1236-1399	13,990	933	90	243,400	(2) 7.5	1860	40,340	14,480	63,740	1,332	288	(1) 14	1,428	49,560	2' 9 1/4"	13' 9 1/2"
12 x 36	XLP2-1236-1412	14,120	941	45	194,800	(2) 7.5	1860	52,190	20,450	76,230	1,980	428	(1) 14	1,428	62,060	4' 3 3/4"	15' 4"
12 x 36	XLP2-1236-1464	14,640	976	60	219,300	(2) 7.5	1860	46,240	17,460	69,960	1,656	358	(1) 14	1,428	55,780	3' 6 1/2"	14' 6 3/4"
12 x 36	XLP2-1236-1468	14,680	979	30	159,400	(2) 7.5	1860	62,350	25,550	86,980	2,564	554	(1) 14	1,428	72,810	5' 1"	16' 1 1/4"
12 x 36	XLP2-1236-1489	14,890	993	45	194,000	(2) 7.5	1860	55,980	22,340	80,250	2,203	476	(1) 14	1,428	66,080	4' 3 3/4"	15' 4"
12 x 36	XLP2-1236-1513	15,130	1009	60	214,300	(2) 7.5	1860	52,210	20,450	76,250	1,980	428	(1) 14	1,428	62,080	4' 3 3/4"	15' 4"
12 x 36	XLP2-1236-1545	15,450	1030	90	236,200	(2) 7.5	1860	46,310	17,460	70,030	1,656	358	(1) 14	1,428	55,850	3' 6 1/2"	14' 6 3/4"
12 x 36	XLP2-1236-1597	15,970	1065	60	213,600	(2) 7.5	1860	56,000	22,340	80,270	2,203	476	(1) 14	1,428	66,100	4' 3 3/4"	15' 4"
12 x 36	XLP2-1236-1600	16,000	1067	90	230,800	(2) 7.5	1860	52,280	20,450	76,320	1,980	428	(1) 14	1,428	62,150	4' 3 3/4"	15' 4"
12 x 36	XLP2-1236-1619	16,190	1079	45	182,400	(2) 7.5	1860	62,390	25,550	87,020	2,564	554	(1) 14	1,428	72,850	5' 1"	16' 1 1/4"
12 x 36	XLP2-1236-1670	16,700	1114	90	245,300	(2) 7.5	1860	52,290	20,450	76,330	1,980	428	(1) 14	1,428	62,160	4' 3 3/4"	15' 4"
12 x 36	XLP2-1236-1684	16,840	1123	90	230,000	(2) 7.5	1860	56,070	22,340	80,340	2,203	476	(1) 14	1,428	66,170	4' 3 3/4"	15' 4"
12 x 36	XLP2-1236-1735	17,350	1157	60	200,800	(2) 7.5	1860	62,410	25,550	87,040	2,564	554	(1) 14	1,428	72,870	5' 1"	16' 1 1/4"
12 x 36	XLP2-1236-1760	17,600	1173	90	244,400	(2) 7.5	1860	56,080	22,340	80,350	2,203	476	(1) 14	1,428	66,180	4' 3 3/4"	15' 4"
12 x 36	XLP2-1236-1831	18,310	1221	90	216,400	(2) 7.5	1860	62,480	25,550	87,110	2,564	554	(1) 14	1,428	72,940	5' 1"	16' 1 1/4"
12 x 36	XLP2-1236-1887	18,870	1258	120	269,000	(2) 7.5	1860	56,330	22,340	80,600	2,203	476	(1) 14	1,428	66,430	4' 3 3/4"	15' 4"
12 x 36	XLP2-1236-1904	19,040	1270	90	230,000	(2) 7.5	1860	62,490	25,550	87,120	2,564	554	(1) 14	1,428	72,950	5' 1"	16' 1 1/4"
12 x 36	XLP2-1236-2036	20,360	1358	120	252,160	(2) 7.5	1860	62,740	25,550	87,370	2,564	554	(1) 14	1,428	73,200	5' 1"	16' 1 1/4"
12 x 36	XLP2-1236-2148	21,480	1432	150	271,600	(2) 7.5	1860	62,870	25,550	87,500	2,564	554	(1) 14	1,428	73,330	5' 1"	16' 1 1/4"

NOTES:

- Model number denotes condenser box size followed by nominal condenser capacity in MBH ÷ 10 at 96.3°F condensing and 78°F wet bulb; for example: XLP2-512-130 has 5' x 12' box size and 1,300 MBH.
- MBH at 96.3°F condensing and 78°F wet bulb with R-717.
- R-717 tons are at a 96.3°F condensing temperature, a 20°F suction temperature, and a 78°F entering wet-bulb temperature.
- Operating weight shown is based on total unit weight, weight of refrigerant operating charge, and cold water basin filled to the overflow level.
- Unless otherwise noted, the coil section is the heaviest section.
- Standard refrigerant connection size is 4" BFW (inlet and outlet).
- Refrigerant charge listed is R-717 operating charge. To determine operating charge for R-134a, multiply by 1.98.

Engineering Specifications

See our website at www.johnsoncontrols.com for an electronic copy of product engineering specifications.

1.0 Evaporative Condenser

1.1 General: Furnish and install, _____ factory assembled evaporative condenser(s) of counterflow blow-through design, with single side air inlet, conforming in all aspects to the specifications and schedule as shown on the plans. The unit shall have self-aligning pan and casing section for easy rigging and shall have an access door(s) for easy access maintenance and dimensions of at least 30" x 42".

1.2 Thermal Capacity: The evaporative condenser(s) shall be warranted by the manufacturer to have condensing capacity of _____ BTUH (kW) heat rejection, operating with _____ refrigerant and _____ °F (°C) condensing temperature and _____ °F(°C) entering wet-bulb temperature.

1.3 DuraTest™ Construction: Unless otherwise noted in this specification, all steel panels and structural members shall be protected with the thermosetting hybrid polymer. The corrosion resistance system shall consist of G-235 (Z700 metric) hot-dip galvanized steel prepared in a four-step (clean, pretreat, rinse, dry) process with an electrostatically sprayed, thermosetting hybrid polymer fuse-bonded to the substrate during a thermally activated curing stage and monitored by a 23-step quality assurance program. Any other coatings must be submitted to the engineer for pre-approval. The cold water basin is protected with TripleGuard™ Corrosion Protection System: The system shall consist of G-235 galvanized steel encapsulated with a thermosetting hybrid polymer further protected by a polyurethane liner factory applied to all submerged surfaces. The polyurethane barrier shall seal all factory seams in the cold water basin to ensure a corrosion resistant and water tight construction, and shall be warranted against leaks and corrosion for five (5) years. A welded Type 304 or 316 stainless steel basin shall be an acceptable alternative; provided the basin is warranted against leaks and corrosion for a period of at least 5 years. A bolted basin shall not be an acceptable alternative. Type 301 stainless steel is not acceptable.

1.4 Wind and Seismic Forces: The unit shall be shake table tested at a certified independent dynamic testing laboratory and comply with 2006 IBC code.

1.5 Quality Assurance: The manufacture shall have a Management System certified by an accredited registrar as complying with the requirements of ISO-9001 to ensure consistent quality of products and services. Manufacturers that are not ISO-9001 certified shall provide an additional one-year warranty to the customer at no additional cost.

1.6 Warranty: The manufacturer's standard equipment warranty shall be for a period of one year from the date of startup or eighteen months from the date of shipment, whichever ends first. The manufacturer shall, in addition, provide a 5-year mechanical drive warranty covering the fans, fan shafts, bearings, sheaves, supports, and fan motors.

2.0 Construction Details

2.1 Corrosion Resistant Construction: Unless otherwise noted in this specification, all steel panels and structural members

shall be constructed from heavy-gauge, G-235 (Z700 metric) hot-dip galvanized steel, encapsulated with a thermosetting hybrid polymer.

2.2 Casing Assembly: The evaporative condenser shall include a coil casing section consisting of a serpentine coil, spray water distribution system, and drift eliminators, as indicated by the manufacturer. PVC drift eliminators shall be removable in easily handled sections. They shall incorporate a minimum of three changes in air direction.

2.3 Cold Water Basin: The cold water basin shall be protected with the TripleGuard™ Corrosion Protection System. The system shall consist of G-235 galvanized steel encapsulated with a thermosetting hybrid polymer further protected by a polyurethane liner factory applied to all submerged surfaces. The polyurethane barrier shall seal all factory seams in the cold water basin to ensure a corrosion resistant and water tight construction, and shall be warranted against leaks and corrosion for five (5) years. Field applied polyurethane or polyurethane applied directly to galvanized steel is not an acceptable alternative. Standard basin accessories shall include: a corrosion resistant makeup valve with large diameter polystyrene filled plastic float for easy adjustment of the operating water level, removable anti-vortexing device to prevent air entrainment, and large area lift out strainers with perforated openings sized smaller than the water distribution system nozzles. The strainer and antivortexing device shall be constructed from Type 304 stainless steel to prevent corrosion. A welded Type 304 or 316 stainless steel basin shall be an acceptable alternative; provided the basin is warranted against leaks and corrosion for a period of at least 5 years. A bolted basin shall not be an acceptable alternative. Type 301 stainless steel is not acceptable.

2.4 Coil Assembly: The refrigerant condensing coil shall be fabricated of continuous lengths of all prime surface steel at the manufacturer's own facility, and hot-dip galvanized after fabrication (HDGAF). The refrigerant condensing coil shall be tested at 375 psig (2,687 kPa) air pressure under water. The refrigerant condensing coil shall be designed for low pressure drop with sloping tubes for free drainage of liquid refrigerant. The refrigerant condensing coil shall be ASME B31.5 compliant and coils shipping into Canada shall be supplied with a CRN.

2.5 Water Distribution System: Water shall be distributed evenly over the coil at a minimum flow rate of 4.5 gpm/ft² (3.1 lps/m²) to ensure complete wetting of the coil at all times. The water distribution system shall have an operating pressure of 2 psig (115 kPa) at the evaporative condenser spray water inlet connection. Spray nozzles shall utilize a two-stage diffusion pattern to provide overlapping, umbrella spray patterns. Nozzles shall have a minimum of 0.25" (6.35 mm) protrusion inside the spray branches to ensure unimpeded water flow between regular cleanings. Nozzles shall be removable without any tools for cleaning. Directional nozzles shall not be acceptable. Spray branches shall be held in place by snap-in rubber grommets, allowing quick removal of complete branches for cleaning or flushing. Spray branches shall be

removable without the use of any tools and constructed out of Schedule 40 PVC.

2.6 Water Recirculation Pump: shall be a close-coupled, bronze-fitted centrifugal pump equipped with a mechanical seal, mounted on the basin and piped from the suction strainer to the water distribution system. The pump shall have a bronze impeller. The pump shall be installed so that it may drain freely when the basin is drained. The pump assembly shall include an integral metering valve and bleed line to control the bleed rate from the pump discharge to the overflow connection. The pump motor shall be totally enclosed fan cooled (TEFC) type suitable for ____ V, ____ phase, ____ Hz electrical service.

2.7 Drift Eliminators: Removable PVC drift eliminators shall be positioned to prevent moisture from leaving the evaporative condenser and incorporate a minimum of three (3) changes in air direction.

3.0 Mechanical Equipment

3.1 Fan(s): Air shall enter the evaporative condenser through the axial fan assemblies and integral air plenum. Each fan assembly shall contain two axial-flow fans mounted in series on a common shaft with discharge guide vanes between the fans for increased fan efficiency. Fans shall be heavy-duty, axial flow type with aluminum alloy blades driven by a one-piece, multigroove neoprene/polyester belt designed for a minimum of 150% of the motor nameplate horsepower. Fan cylinders shall have curved inlets for efficient air entry. Air inlet screens shall be OSHA compliant.

3.2 Bearings: Fan shafts shall be mounted in heavy-duty, self aligning, grease-packed relubricatable ball bearings with eccentric locking collars, designed for a minimum L₁₀ life of 94,000 hours. Bearing lubrication lines shall be extended to the exterior of the unit.

3.3 Fan Motor(s): Fan motors and drives shall be located at the front base of the unit to facilitate access without requiring access to the inside of the unit. Fans and motors shall be located in the dry entering airstream to provide greater reliability and ease of maintenance. Fan motor bases shall be adjustable for belt tensioning by adjusting a single nut. Fan motor(s) shall be totally enclosed fan cooled (TEFC) type, premium efficiency/VFD ready with a 1.15 service factor, suitable for ____ V, ____ phase, ____ Hz electrical service and shall be mounted on an easily adjusted, heavy-duty motor base. Fan motors shall comply with NEMA Standard MG 31, Section IV, Part 31.

4.0 Sound

4.1 Sound Level: To maintain the quality of the local environment, the maximum sound pressure levels (dB) measured 50 ft (15,240 mm) from the evaporative condenser operating at full fan speed shall not exceed the sound levels detailed below.

Location	63	125	250	500	1000	2000	4000	8000	dB(A)
Discharge									
Air Inlet									
Cased Face									

5.0 Accessories

5.1 Basin Heater(s): Basin heater(s) shall be electric immersion type controlled by a remote thermostat with the sensing bulb located in the basin water. Basin heaters shall be provided with a factory-installed low water level cutout switch to prevent heater operation unless the heater elements are fully submerged.

5.2 Vibration Cutout Switch: Provide an electronic remote reset vibration switch with contact for BAS monitoring. Wiring shall be by the installing contractor. The electronic vibration cutout switch shall be set to trip at a point so as not to cause damage to the unit. To ensure this, the trip point will be set in a frequency range of ____ to ____ Hertz and a trip point of ____ in/sec (____m/sec).

5.3 External Access: Evaporative condenser shall be provided with a factory assembled, field-installed external platform with an access ladder and handrails complying with OSHA standards and regulations to provide access to the top of the evaporative condenser. External platform shall have a 24" (610 mm) wide nonskid walking surface and 42" (1,220 mm) high safety railings. Optional safety cage shall be available to meet OSHA requirements as necessary.

5.4 Single-point Factory Wiring: The evaporative condenser shall be provided with a UL-Listed Stainless Steel NEMA 3R Electrical Box and wires run in UL-Listed conduit from the box to all electrical components on the unit, including fan(s), pump(s), and optional VCOS, EWLC + solenoid and basin heater.

5.5 Basin Sweeper Piping: The cold water basin of the unit shall be equipped with PVC sump sweeper piping for a separator (supplied by others).

Q-NET™ network technology...

Connect Your PC
with QUANTUM™LX!

*Take full advantage of Q-NET™
technology with all Frick products!*

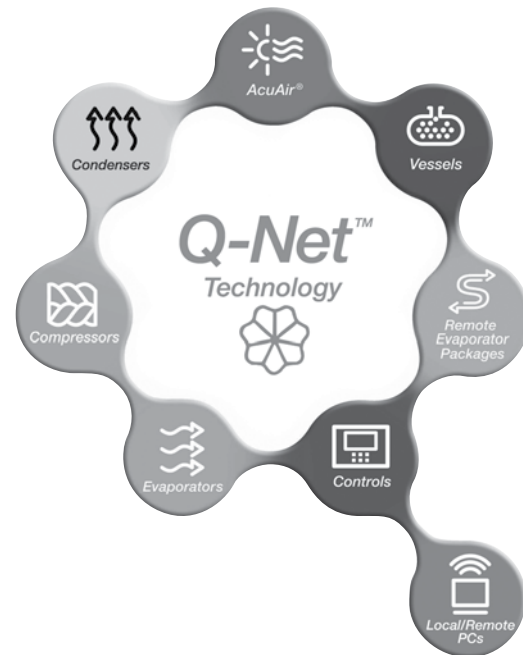

System integration is what we do...

- Q-NET™ ... supports open-protocols for SCADA systems (i.e. Allen-Bradley® DF1, Modbus RTU, Modbus ASCII, and Industrial Ethernet Protocols)
- Q-NET™ ... connects instantly for local or remote access; no software required
- Q-NET™ ... can be applied to both new and existing systems
- Q-NET™ means precise control 24 hours a day, seven days a week
- Q-NET™ distributed architecture mean faster, easier, economical installations
- Q-NET™ delivers increased operating efficiency and lowers energy costs

Available on Frick screw compressors, condensers, evaporators, AcuAir® hygienic air handlers, and refrigerant vessels.